

## Bekisopa Southern Zone DSO Resource Upgrade

**5.54 m tonnes Indicated & Inferred Resource at 60.35% Fe, a 34% uplift**

**4.42 m tonnes Indicated Resource at 60.9% Fe, all at a 58% Fe cut-off grade**

## Bekisopa Southern Zone “Green Steel” Resource Update

**Defined a 34 m tonne high-grade “Green Steel” Resource\* grading 45.3% Fe, 58% DTR delivering a 68.7% Fe concentrate at 75 microns.**

### Highlights: Bekisopa DSO Resource Upgrade

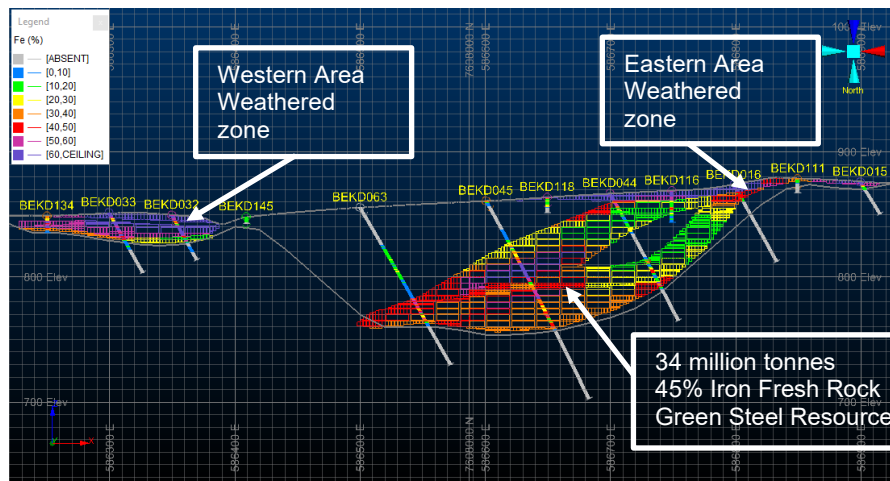
- 5.54 million tonne DSO Indicated and Inferred Resource at 60.35% Fe, including
- **4.42 million tonnes DSO Indicated Resource at 60.9% Fe**
- Eastern Area Indicated Resource 2.8 million tonnes at 61.3% Fe
- Western Area Indicated Resource 1.6 million tonnes at 60.2% Fe, all at a 58% Fe cut-off
- DSO tonnes, in Inferred or Indicated categories, along the Bekisopa 6-kilometer strike is now **9.14 Mt** excluding the high-grade outcrop

### Highlights: Bekisopa “Green Steel” Resource Update

Additional work has identified within the 2022 Maiden Inferred Resource a

- **34 million tonne** fresh rock “Green Steel” resource directly beneath the Eastern Area Indicated DSO resource at a 36% Fe cut-off
- **45.3% Fe head grade**
- **58% DTR** (mass yield) which means **1 tonne of concentrate produced from 1.7 mined tonnes**
- **68.7% Fe green steel concentrate** at an **88.0% Fe recovery**

**Note:** \* - “Green Steel” Resource is the term Wardell Armstrong International has given to a section of very high-grade fresh rock iron mineralisation that has been shown to readily upgrade to produce a high-grade concentrate ideal for direct reduced iron pellets for Green Steel production.



**WAI Block Model showing the Western and Eastern DSO mineralisation and the significant 34 million tonne Green Steel zone below the Eastern DSO resource.**

AKORA Resources Managing Director and CEO, Paul Bibby commented: *“It is very encouraging to report upgraded DSO tonnes and grade from last year’s infill drilling campaign. These 5.54 million tonnes will be the mined tonnes for a lower processing capital and operating cost DSO startup. Beneath the weathered DSO Eastern zone is a high-grade magnetite iron mineralised zone, of 34 million tonnes at 45.3% iron, that could become the focus of an economical Green Steel concentrate production startup.”*

### Next Steps

Presently preparing for additional 800 metres of DSO infill drilling across the Bekisopa Northern and Central Zones to further expand start-up DSO tonnage.

WAI to commence a review of the unreleased 2022 Scoping Study based on the Indicated DSO start-up tonnes and grade.

The definition of “Green Steel” as used by WAI is “the production of steel without the use of fossil fuels and coking coal and powered using natural gas and potentially hydrogen and other renewables. For steel to be produced in this manner, that is, no carbon from coking coal as the main reductant, the grade of the iron ore feed must be both very high in iron content, greater than 67% Fe, and very importantly low in impurities of Silica and Alumina”.

Iron concentrates from Bekisopa are at 68.7% Fe and with combined silica and alumina impurity levels averaging less than 2%, this is likely to be very suitable as Green Steel iron ore feed material.

## Introduction – Mineral Resource update from the 2022 Southern Zone infill drilling

AKORA Resources announced a Maiden Inferred Mineral Resource at Bekisopa of 194.7 million tonnes (ASX Announcements 23 March 2022 and 11 April 2022). The Southern Zone inferred resource was 110.2 mt including an estimated 4.2 mt of DSO potential at a 57% iron grade.

In October 2022 AKORA completed an infill drilling campaign across the Bekisopa Southern Zone comprising 1,166.4 metres across 86 close-spaced drill holes at a 50m by 50m spacing (see Figure 1 below) to define additional DSO tonnes and grade.

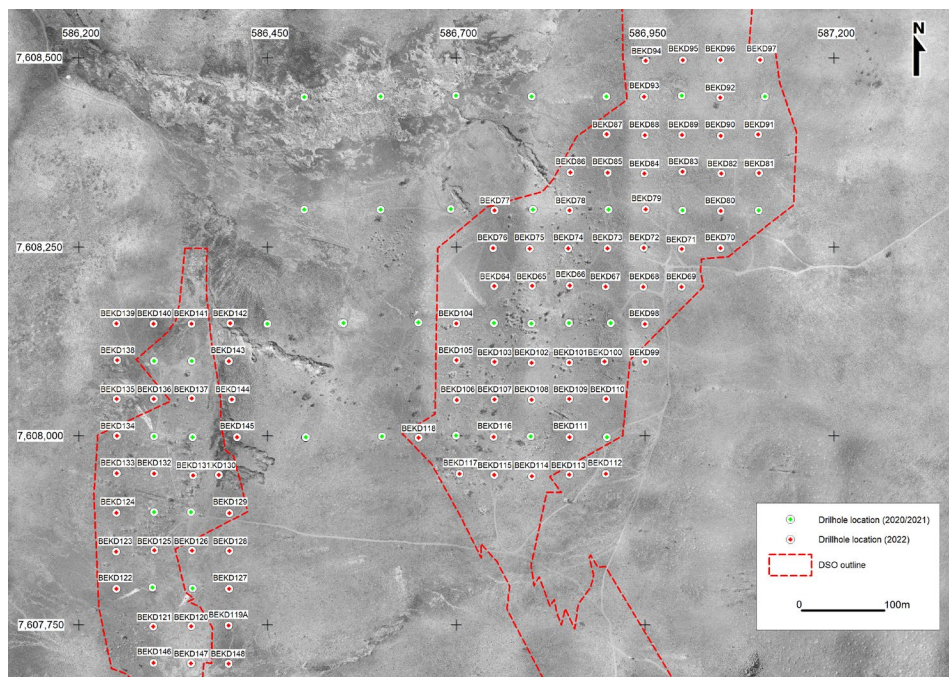


Figure 1.

Location for the 86 shallow DSO infill drill holes for upgrading the DSO Mineral Resource Estimate.

All 2022 infill drilling assay results, and the previous 2020 and 2021 drilling results, were provided to Wardell Armstrong International (WAI) to deliver an updated Southern Zone DSO Mineral Resource Estimate (MRE). In total, 123 shallow drill holes have been drilled for 4,817m drilled, 3,738 drill intercepts have been assayed and 2,178 Davis Tube tests have been conducted within this Southern Zone for the MRE.

As announced by AKORA on the 11 April 2022, the H&S Maiden Resource Estimate for the Bekisopa Southern Zone reported an overall 110.2 mt Inferred Resource at 32% Fe which included an estimated 4.2 mt DSO at 57% Fe.

The recent infill DSO drilling has increased the total DSO resource to 5.54 mt at 60.35% Fe Indicated and Inferred categories, within this is a **4.42 mt DSO Indicated Resource grading 60.86% Fe** (see Table 1 and Figure 2 and 3).

<b>Southern Zone</b>	<b>Classification</b>	<b>Tonnes (Mt)</b>	<b>Fe (%)</b>	<b>SiO<sub>2</sub> (%)</b>	<b>Al<sub>2</sub>O<sub>3</sub> (%)</b>	<b>Density (t/m<sup>3</sup>)</b>
<b>Western DSO Zone</b>	<b>Indicated</b>	<b>1.63</b>	<b>60.15</b>	<b>7.01</b>	<b>2.65</b>	<b>3.68</b>
	Inferred	0.33	58.83	6.37	2.54	3.74
<b>Eastern DSO Zone</b>	<b>Indicated</b>	<b>2.80</b>	<b>61.28</b>	<b>4.80</b>	<b>3.38</b>	<b>3.21</b>
	Inferred	0.79	58.13	6.04	4.23	2.92
<b>TOTAL DSO</b>	<b>Indicated</b>	<b>4.42</b>	<b>60.86</b>	<b>5.61</b>	<b>3.11</b>	<b>3.37</b>
	Inferred	1.12	58.34	6.14	3.73	3.13
<b>TOTAL DSO</b>	<b>Indicated and Inferred</b>	<b>5.54</b>	<b>60.35</b>	<b>5.72</b>	<b>3.24</b>	<b>3.32</b>
<b>H&amp;S 2022 DSO</b>	<b>Estimated</b>	<b>4.2</b>	<b>57%</b>	<b>-</b>	<b>-</b>	<b>2.57</b>

Table 1.

Upgraded Bekisopa Southern Zone DSO Resource, at 5.54 mt is an increase above the 2022 H&S Maiden DSO Resource estimate.

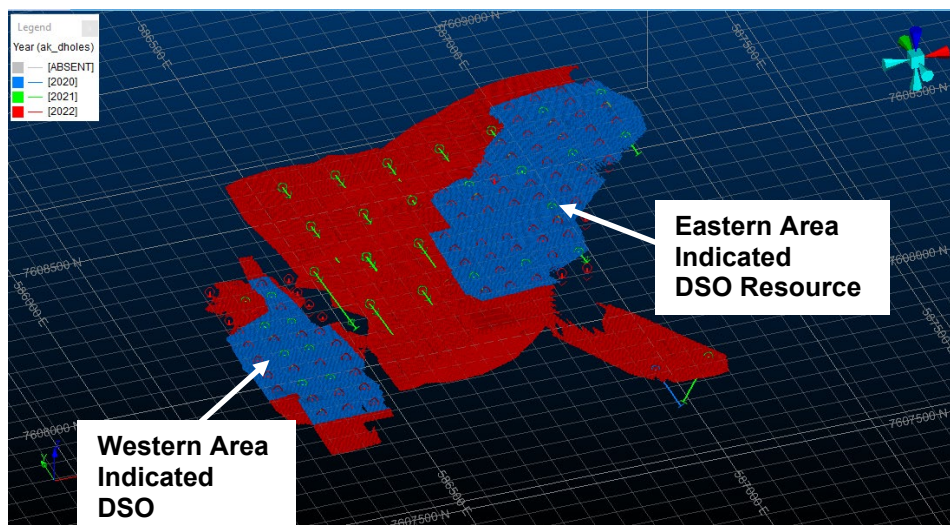


Figure 2.

Bekisopa South Mineral Resource Classification: Blue areas – Indicated and Red areas – Inferred.

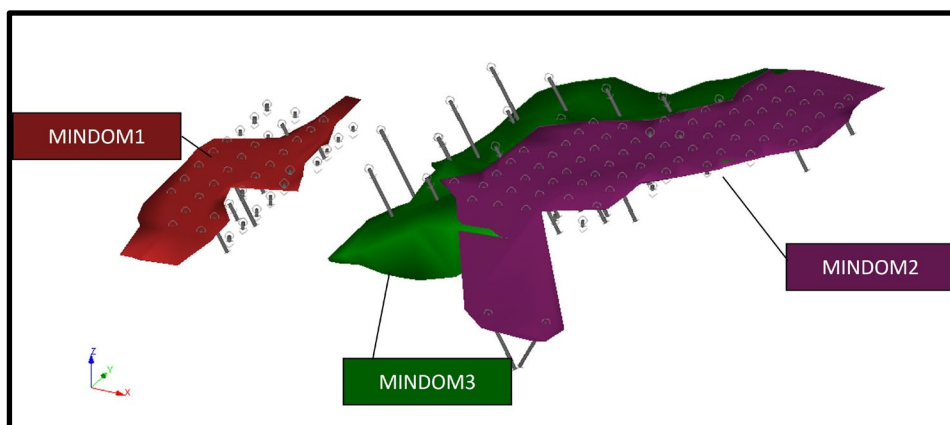


Figure 3.

Resource block model showing the main mineralisation domains. MINDOM (Mineral Domain) 1 and 2 are the Western and Eastern DSO envelopes, incorporating the 2020, 2021 and 2022 DSO infill drilling results.

MINDOM 3 is the Green Steel very high-grade mineralisation envelope.

The Mineral Resource Estimate was carried out with a 3D block modelling approach to define the mineralisation envelopes and based on a nominal cut-off grade of 58% Fe for DSO material. A model prototype with a parent cell size of 20m x 20m x 5m (X, Y, Z (Depth)) was used for this initial volumetric model. Sub-cell splitting to a minimum cell size of 2.5m x 2.5m x 1m (depth) was applied within the weathered DSO iron mineralisation (see Figure 4). The smaller sub-cells were selected to match the selective mining approach proposed at Bekisopa for the DSO start-up mining phase.

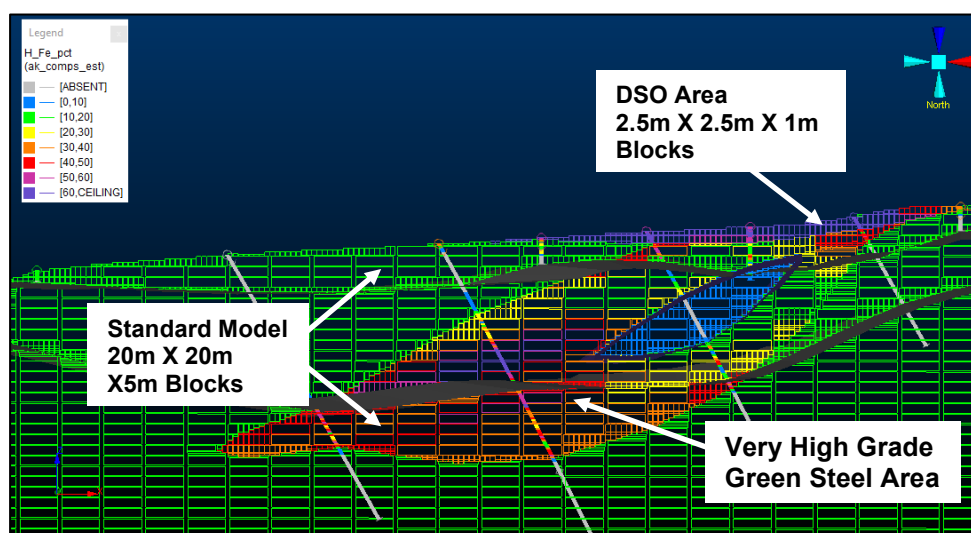


Figure 4.

Bekisopa Southern Zone Section Showing the two block model sizes, 20m X 20m X 5m and the smaller 2.5m X 2.5m X 1m in the areas of shallow DSO and at the interfaces between iron mineralisation types. Eastern Area containing at surface DSO and beneath an area of high-grade iron mineralisation for Green Steel.

#### Indicated Mineral Resource Classification.

The Mineral Resource classification for the Bekisopa Southern Zone was undertaken by WAI in accordance with the Australasian Code for Reporting of Exploration Results, Mineral Resources and Ore Reserves [JORC Code (2012)]. WAI considers that the **Bekisopa Southern Zone has been sufficiently explored to assign an Indicated Resource** and an Inferred mineral resource as defined by the JORC Code (2012). The relatively close spaced drilling in areas of Bekisopa South are enough for iron mineralisation continuity to be assumed.

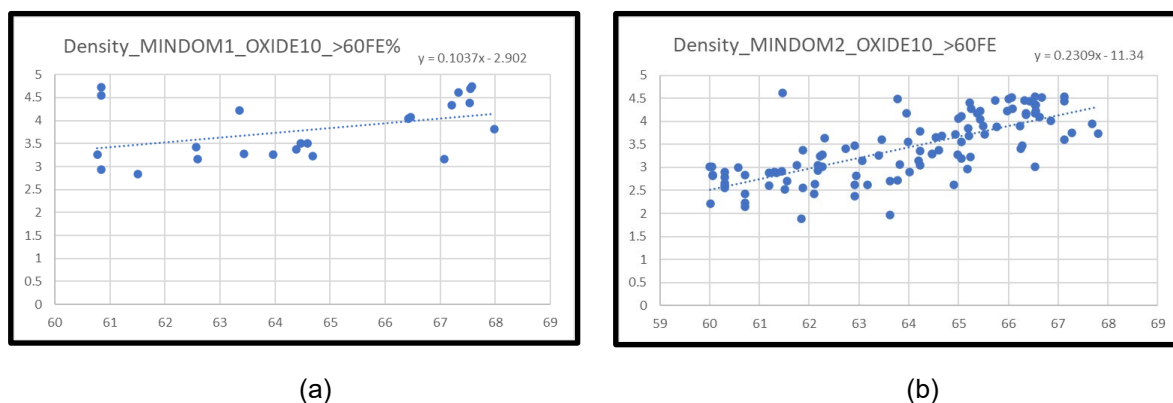
WAI believes that an absence of an overall geological and structural model precludes the classification of Measured Mineral Resources. **WAI recommends** that a geological and structural model for the deposit should be developed. Such a model should assist in defining a higher category MRE.

There are no known mining, metallurgical, infrastructure, or other factors that materially affect this Mineral Resource Estimate, at this time.

### Iron Mineralisation Density.

The WAI DSO MRE has defined a 5.54 million tonnes resource, this is an important start-up tonnage for further work in the upcoming review of the Scoping Study. A key factor in determining the resource tonnage is the iron mineralisation density and as noted in Table 1 above the average density used was 3.32 t/m<sup>3</sup>.

Density measurements conducted in the field are performed using the Vernier Calliper Method (VCM) on weathered zone samples and by the Archimedes Principle method (APM) on competent fresh iron mineralisation samples. The VCM measurements, possibly due to the weathered nature of the surface DSO, appear to produce a lower-than-expected density result for a particular iron grade sample. Density measurements for the Eastern and Western area DSO are shown in Figure 5 and shows considerable variability due to the characteristics of the weathered rocks.



**Figure 5.**

**In field density measurements for the (a) Western Area DSO and (b) Eastern Area DSO, grading >60% Fe. The average results are lower than is expected.**

The density of pure hematite (69.9% Fe) and magnetite (72.4% Fe) are 5.3 t/m<sup>3</sup> and 5.2 t/m<sup>3</sup>, respectively. Therefore, expected density measurements for iron mineralisation grading (say) 58 to 68% Fe would be around 4 to 5 t/m<sup>3</sup>, for competent unweathered rock, considerably higher than used in the WAI resource calculations. A higher average or specific grade density is expected result in an increased the overall MRE tonnage.

AKORA proposes to validate the density measurements with laboratory test work to further confirm the densities for specific iron grades in the DSO zones. Expectation is that higher density measurements may be produced which would have a positive impact on the overall MRE tonnes.

## High-Grade Iron Mineralisation beneath the Eastern DSO Zone

WAI performed additional Mineral Resource Estimation evaluation on the Southern Zone drilling data. This work has revealed an area of very high-grade iron mineralisation below the confirmed WAI Eastern Area DSO resource tonnage. This Green Steel resource is within the H&S April 2022 Southern Zone Maiden Resource. The H&S Inferred Resource defined 110.2mt at 32% Fe, this was from across the Southern Zone as shown in all the red and blue areas in Figure 2, compared to only the three smaller areas in Figures 3 and 6 defined by WAI.

WAI has concluded that, after selective mining of the DSO, there is a region of high-grade fresh rock that could be the focus of an initial mining and processing operation to produce a high-grade concentrate, termed the “Green Steel” resource. Davis tube test (DTT) show that is likely to produce a 68.7% Fe concentrate from an average iron grade of 45.3% Fe, at an excellent Davis Tube Recovery (mass yield) of 58% at 75 microns (see Table 2).

	Classification	Tonnes (Mt)	Fe (%)	DRI Concentrate (% Fe)	DTR (%)
<b>WAI 2023 Green Steel</b>	<b>Inferred</b>	<b>34.00</b>	<b>45.26</b>	<b>68.7</b>	<b>58</b>

Table 2.

**Very high-grade iron mineralisation beneath the Eastern DSO Indicated Resource.**

This **green steel** production section of **34 million tonnes at a DTR of 58%** should deliver **21.1 million tonnes of 68.7% Fe high-grade DRI concentrate** which is the ideal feed for the Green Steel future (see Figure 6). As seen in Figure 7 this significant high-grade zone is beneath the Eastern Area DSO zone which can be readily mined after selectively mining the DSO during a start-up operation. Resources for the Green Steel zone are reported using a cut-off grade of 36% Fe and forecast to be mined from an optimised open pit shell.

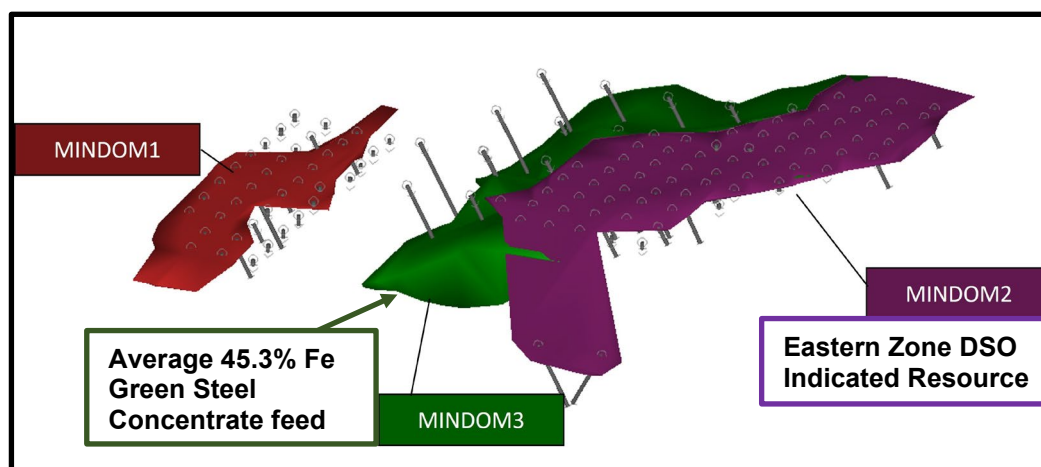


Figure 6.

**MINDOM 3 is an area of 45.3% iron suitable for upgrading to a DRI 68.8% iron concentrate for the Green Steel future.**

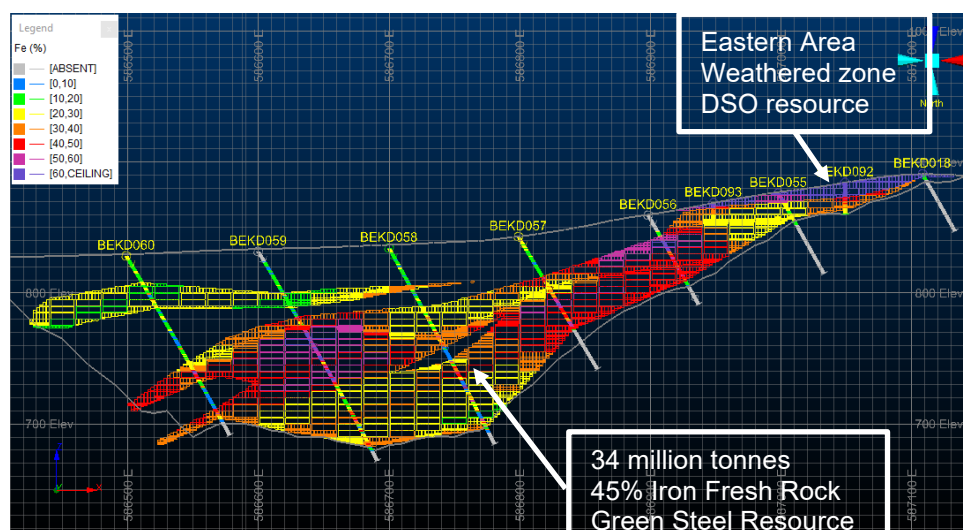


Figure 7.

**Cross-Section through the Eastern Zone Very high-grade green Steel area, averaging 45.3% iron suitable for upgrading to a DRI 68.8% iron concentrate for the Green Steel future.**

For AKORA this very high-grade DRI concentrate feed mineralisation at 45.3% Fe offers the potential for a lower-than-expected Green Steel start-up operation. This outcome results from the known coarse iron mineralisation at the Bekisopa project in conjunction with the higher average feed grade and the outstanding DTR of 58%. Combined this results in lower mined feed tonnes per tonne of high-grade 68.7% Fe concentrate produced, than previously observed from the Southern Zone fresh iron mineralisation (see Table 3).

	Classification	Resource Tonnes (mt)	Fe (%)	DRI Concentrate (% Fe)	DTR (%)	Feed tonnes per concentrate tonne
H&S 2022 Southern Zone	Inferred	110.2	32	67.6	37.8	2.6
<b>WAI 2023 Green Steel (sub-set)</b>	<b>Inferred</b>	<b>34</b>	<b>45.3</b>	<b>68.7</b>	<b>58</b>	<b>1.7</b>

Table 3.

**Comparison of the current WAI Green Steel Area compared to the 2022 H&S Maiden Inferred Southern Zone resource. A 42% higher head grade and a 53% higher DTR results in significantly less mined tonnes per concentrate tonne produced.**

The WAI identified Green Steel tonnes are from within a section of the broader H&S total Southern Zone resource. The remaining resource tonnage defined by H&S (110mt less 5.5mt DSO less 34mt being 70mt) are then available to be mined to produce a high-grade concentrate.

The 2023 WAI Green Steel resource area with a 58% DTR means that **only 1.7 mined tonnes are required to produce 1 tonne of 68.7% Fe concentrate**, compared to 2.6 mined tonnes previously expected. This means an initial lower capital and operating cost mining and processing advantage from this Green Steel feed area.

## Conclusions.

### DSO Mineral Resource upgraded to Indicated

WAI was commissioned by AKORA to produce an updated Mineral Resource estimate for the Bekisopa Southern Zone Iron Project. The Bekisopa project comprises three zones – Northern, Central and Southern zones and is a meaningful greenfield project. It is the goal of AKORA to develop an open pit operation with an initial focus on rapidly bringing into production near-surface, weathered iron material as DSO lump and fines.

The WAI updated MRE is a total of **5.54 million tonnes of DSO Inferred resource grading 60.35% Fe**, this is 32% more DSO tonnes than estimated in April 2022 and at a higher grade.

Within this Indicated and Inferred resource is **4.42 million tonnes of DSO grading 60.86% Fe in the Indicated category**. This DSO is believed suitable for a selective mining DSO start-up that should have relatively low mining and processing capital and operation costs.

This updated Southern Zone MRE of 5.54 million tonnes is in addition to the previously estimated 3.6 million tonnes reported in the Northern and Central Maiden MRE's, **current total DSO resource of 9.14 million tonnes**. Expectation is that further drilling in all three Bekisopa zones would add additional DSO tonnes and grade. Should also note that these reported MRE do not include the observed high-grade outcropping iron mineralisation that is believed suitable for additional DSO lump and fines products.

### Green Steel Resource – 34 million tonnes at 45.3% Fe

Underlying the Eastern surface DSO zone is a larger, deeper zone of fresh rock iron mineralisation that WAI has termed the “Green Steel” zone. This additional work by WAI has identified a very high-grade iron zone, average head grade of **45.3% Fe** which is considered amenable for **upgrading to a high-grade 68.7% Fe concentrate** for use in the production of DRI pellets for green steel. This newly identified high-grade Green Steel zone sits within the overall 110.2 million tonne H&S Inferred Resource for the Southern Zone announced in April 2022.

**Further WAI expects that this “Green Steel” zone is readily upgradeable at a low 1.7 mined tonnes per 1 tonne of outstanding 68.7% Fe concentrate at 75 microns**. Also, this potential mining area for Green Steel concentrate production is expected to be at a lower mining and processing capital and operating cost because of the high grade of 45.3% Fe and the high DTR at 58%.

**For further information please contact:**

Paul G Bibby  
Managing Director  
Phone +61(0) 419 449 833  
[www.akoravy.com](http://www.akoravy.com)

Matthew Lindh  
Investor Relations  
Phone +61(0) 432 363 933  
[mlindh@harbury.com.au](mailto:mlindh@harbury.com.au)

**About AKORA Resources**

AKORA Resources (ASX: AKO) is an exploration company engaged in the exploration and development of the Bekisopa, Satrokala, Tratramarina and Ambodilafa Projects, all iron ore prospects in Madagascar where AKORA holds some 308 km<sup>2</sup> of tenements across these three prospective exploration areas. Bekisopa Iron Ore Project is a high-grade iron ore project with an ~6km strike length and an Inferred Resource of 194.7 million tonnes. Bekisopa has outcropping and weathered zone DSO iron ore and potential to produce a premium grade +68% iron concentrate suitable for Direct Reduced Iron pellets for the Green Steel future.

**Competent Person Statement**

The information in this report that relates to Mineral Resources for the South Bekisopa Iron Project is based on information prepared by Mr Richard Ellis BSc, MSc, MCSM, FGS, CGeol, EurGeol and is a full-time employee of Wardell Armstrong International. Mr Ellis is a Chartered Geologist of the Geological Society of London and has sufficient experience relevant to the style of mineralisation, the type of deposit under consideration and to the activity undertaken to qualify as a Competent Person as defined in the 2012 edition of the 'Australasian Code for Reporting of Exploration Results, Mineral Resources and Ore Reserves'. Mr Ellis consents to the inclusion of the information in the release in the form and context in which they appear.

**Authorisation**

This announcement has been authorised by the AKORA Resources Board of Directors on 11 July 2023.

**Appendix 1.**

**Wardell Armstrong International – DSO infill drilling  
Mineral Resource Estimate Update Report,  
Including JORC Table 1.**

For personal use only

## Appendix 2.

### **WAI Proposed Schematics for Bekisopa: Processing DSO and for Green Steel concentrate production.**

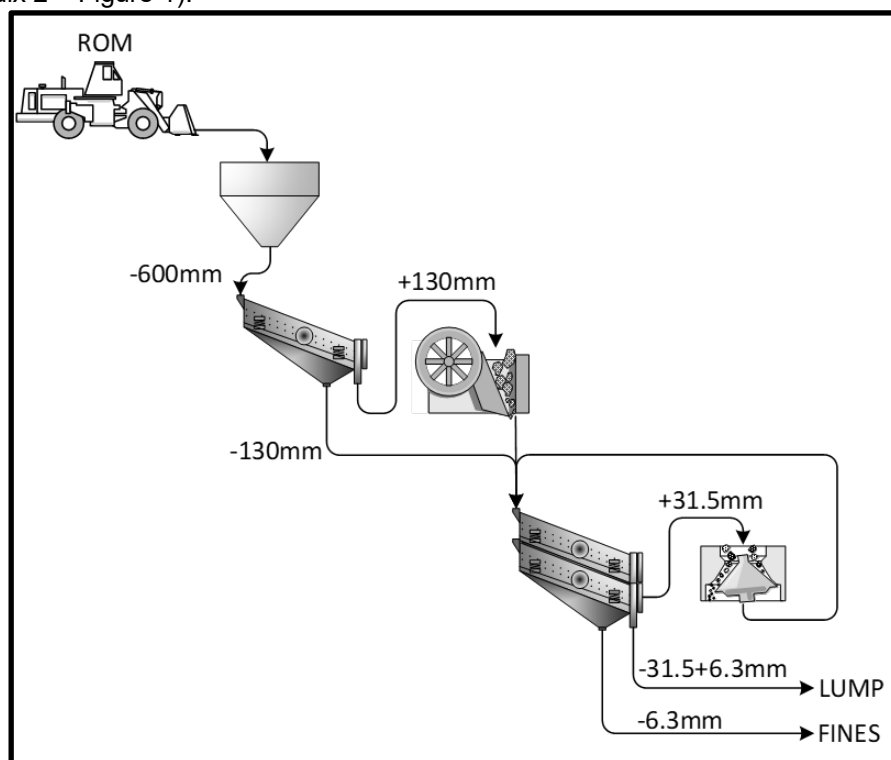
#### **DSO Material – Indicative Process to be evaluated by the Scoping Study.**

DSO material will be mined and processed through a simple crushing and screening plant to produce conventional lump and fines products (lump is  $-31.5+6.3\text{mm}$ ; fines is  $-6.3\text{mm}$ ). A 50:50 split of lump: fines has been assumed. It is anticipated that DSO material will suffice for approximately the first  $\pm 6$  years of operation (though this could be extended to potentially 10 years with additional exploration) before the switch to processing of the massive and coarse disseminated mineralisation.

This is important as, for a relatively low processing capital cost requirement, cashflow can be quickly generated and used to conduct the more detailed studies and testwork required for the main processing options to follow once the DSO material has been exhausted.

The main equipment required (indicative) will typically be a Metso C100 jaw crusher (110kW), an HP400 cone crusher (315kW), a 6.35m x 2.445m triple-deck horizontal screen (30kW) and the associated conveyors and feeders (approximately 170kW). Therefore, the total installed power will be circa 625kW (indicative). With the expectation of installing a solar power station, the energy consumption will therefore be very low and effectively free once the capital cost for the solar farm has been expended.

As an alternative to a fixed plant, it may be desirable to design for portable crushing, screening and conveying units, so that the plant can be moved as required to different areas of the project. It may even be desirable to have two half-capacity portable plants working at different areas simultaneously. This can be further investigated in the next phase of study - for now, a conventional fixed plant is assumed (see Appendix 2 – Figure 1).



**Appendix 2 – Figure 1.**

**Indicative DSO processing Schematic.**

## Green Steel Concentrate – Indicative Process to be evaluated by the Scoping Study.

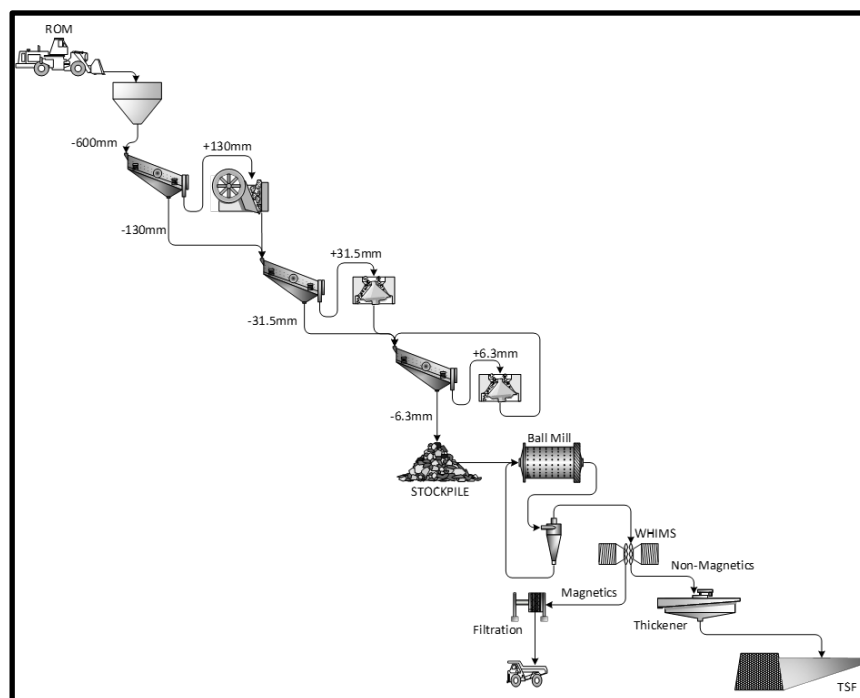
Production of a Green Steel concentrate will require grinding fresh iron mineralisation to -75 microns and Wet High Intensity Magnetic Separation (WHIMS) in order to achieve a +68% Fe concentrate.

Based on the testwork results selectively mining high feed grades (+54% mass recovery to a concentrate grading 69.7% Fe). In this case, it is prudent to allow for a crushed ore stockpile after crushing, with an assumed plant availability for the crushing circuit of 75% and a ball milling/WHIMS circuit availability of 92%. In order to supply conventional ball mill feed, a three-stage conventional crushing circuit is required to produce a -6.3mm crushed product. The secondary crusher will operate in open circuit with the tertiary crusher in closed circuit. In the next phase of study, a trade-off study to evaluate a primary crusher and SAG mill option is recommended.

Crushed product at -6.3mm will be stockpiled and fed via belt feeders to a mill feed conveyor belt and hence to a Ball Mill. The mill will operate in closed circuit with hydrocyclones to achieve a grind size of 80% passing 75 microns. The cyclone overflow will then report to the WHIMS circuit. The magnetic concentrate will be filtered and then trucked to the port and loading facility.

The non-magnetic tailings slurry will be thickened and pumped to the conventional Tailings Storage Facility (TSF). TSF return water will be pumped back to the process water tank. At this stage, it is assumed that a flotation circuit is not required, due to low levels of silica impurities and the expectation that any high impurity lenses of ore can either be left in situ or blended with ROM ore. Based on an assumed Bond Mill Work Index of 17kWh/t (to be determined in the next phase of study) with an 80% passing feed and product size of 6.3mm and 75 microns respectively, then an indicative ball mill required size is 6.7m diameter x 11.1m length with an 8.5MW motor.

The power requirement for the required WHIMS unit would be in the order of 500kW. In total, the plant installed power is therefore likely to be in the order of 10MW. The Block Flow Diagram of the expected flowsheet is shown in Appendix 2 - Figure 2.



Appendix 2 – Figure 2.

Block Flow Diagram of the Typical Circuit for Fine Grind and WHIMS Option to produce a high-grade DRI Pellet concentrate for Green Steel.

**Section 1 Sampling Techniques and Data**

Criteria	JORC Code explanation	Commentary
<i>Sampling techniques</i>	<ul style="list-style-type: none"> <li>• <i>Nature and quality of sampling (eg cut channels, random chips, or specific specialised industry standard measurement tools appropriate to the minerals under investigation, such as down hole gamma sondes, or handheld XRF instruments, etc). These examples should not be taken as limiting the broad meaning of sampling.</i></li> <li>• <i>Include reference to measures taken to ensure sample representivity and the appropriate calibration of any measurement tools or systems used.</i></li> <li>• <i>Aspects of the determination of mineralisation that are Material to the Public Report.</i></li> <li>• <i>In cases where ‘industry standard’ work has been done this would be relatively simple (eg ‘reverse circulation drilling was used to obtain 1 m samples from which 3 kg was pulverised to produce a 30 g charge for fire assay’). In other cases more explanation may be required, such as where there is coarse gold that has inherent sampling problems. Unusual commodities or mineralisation types (eg submarine nodules) may warrant disclosure of detailed information.</i></li> </ul>	<ul style="list-style-type: none"> <li>• Samples consisted of diamond drill core.</li> <li>• Diamond core (HQ or NTW) is split in half using a core saw or splitter (if clayey or rubbly). A consistent half of the core is broken with a hammer and bagged prior to dispatch prior to the preparation laboratory in Antananarivo. Sample intervals are nominally 1m down hole however samples would terminate at lithological and mineralisation boundaries. Average drill core sample length is 0.87m.</li> <li>• Samples generally weighed 3-5kg and were dried, crushed and pulverised to 85% passing 75 microns at a commercial laboratory.</li> <li>• Handheld pXRF (Bruker Titan S1) was used on site prior to being sent to the preparation lab. XRF was used on entire drill lengths from drillholes BEKD001 to BEKD024, after which XRF measurements were conducted on visually identified mineralisation. The handheld XRF was calibrated upon issue.</li> <li>• Head and concentrate assay analysis was completed by conventional XRF (ME-XRF21u) with recovered magnetic fraction completed using a Davis Tube.</li> </ul>
<i>Drilling techniques</i>	<ul style="list-style-type: none"> <li>• <i>Drill type (eg core, reverse circulation, open-hole hammer, rotary air blast, auger, Bangka, sonic, etc) and details</i></li> </ul>	<ul style="list-style-type: none"> <li>• All drilling is diamond core. Drilling contractor Croft Drilling Services (CDS) completed the diamond drilling programmes in 2020-2022 with a man portable EP200 drilling rig for drill holes less than 100m in length, and a MP500 drilling rig for drill holes greater than 100m in length, using either NTW (56.1mm inner diameter)</li> </ul>

For personal use only

For personal use only

Criteria	JORC Code explanation	Commentary
	<i>(eg core diameter, triple or standard tube, depth of diamond tails, face-sampling bit or other type, whether core is oriented and if so, by what method, etc).</i>	<p>or HQ (63.5mm inner diameter) coring equipment. The holes are generally collared using HQ and changed to NTW between 3m and 27m downhole.</p> <ul style="list-style-type: none"> <li>For diamond drill holes in the Southern Zone, minimum length is 4.69m, maximum length is 260.72m, with an average length of 39.16m across all drill campaigns.</li> <li>The drill core is not orientated.</li> <li>All but three drill holes (BEKD001-BEKD003) from 2020-2021 drill campaigns have been surveyed using a Reflex EZ-Gyro gyroscopic multishot camera at intervals of 10m. All drill holes from this period are within 5° of their planned inclination and within 10° of the planned azimuth, except for BEKD061 which was within 15° of the planned azimuth.</li> <li>No downhole surveys were conducted for 2022 drilling as all holes were vertical and &lt;30m in length.</li> </ul>
<i>Drill sample recovery</i>	<ul style="list-style-type: none"> <li><i>Method of recording and assessing core and chip sample recoveries and results assessed.</i></li> <li><i>Measures taken to maximise sample recovery and ensure representative nature of the samples.</i></li> <li><i>Whether a relationship exists between sample recovery and grade and whether sample bias may have occurred due to preferential loss/gain of fine/coarse material.</i></li> </ul>	<ul style="list-style-type: none"> <li>Total Core Recovery (TCR) was measured on site at the drill rig by the supervising geologist.</li> <li>Drillholes with consistently low recovery (&lt;85%) were re-drilled.</li> <li>Average sample recovery is 94% (any samples recorded as having a TCR&gt;100% were excluded from the statistics).</li> <li>Core recovery is higher in fresh rock (average TCR of 97%) than in weathered rock (average value of 90%).</li> <li>A small number of high-grade samples with low recovery are present in near surface weathered zones however, there is no observed relationship between Fe grade and sample recovery.</li> </ul>
<i>Logging</i>	<ul style="list-style-type: none"> <li><i>Whether core and chip samples have been geologically and geotechnically logged to a level of detail to support appropriate Mineral Resource estimation, mining studies and metallurgical studies.</i></li> <li><i>Whether logging is qualitative or quantitative in nature. Core (or costean, channel, etc) photography.</i></li> <li><i>The total length and percentage of the relevant intersections logged.</i></li> </ul>	<ul style="list-style-type: none"> <li>A set of standard operating procedures for drilling and sampling were prepared by AKORA and Vato Consulting, who supervised the program, and these were always adhered to.</li> <li>Checks and verifications of the accurate measurement of penetration depth were made during drilling and observations and recording of the colour of the water/mud rising from the drill hole were made.</li> <li>The entire length of drill core was logged. Pre-defined codes were used to create consistency in qualitative logging.</li> <li>Logging included: Total Core Recovery (TCR) and Rock Quality Designation (RQD), primary and secondary lithology, weathering, colour (supported by Munsell chart), grain size, mineralisation type (magnetite or hematite), mineralisation style and percentage, structure, magnetic susceptibility, pXRF readings, in addition to general descriptions.</li> <li>All drill holes were logged using a magnetic susceptibility meter to enable accurate distinction between magnetite and hematite rich mineralisation.</li> </ul>

For personal use only

Criteria	JORC Code explanation	Commentary
		<ul style="list-style-type: none"> <li>The entire length of drill core was geotechnically logged for TCR and RQD.</li> <li>All core was photographed both as whole core and half core (after cutting and sampling), in addition to both wet and dry states.</li> <li>Density measurements were made using both the Archimedes method (on competent core) and the Caliper Vernier method (on weathered/incompetent core).</li> </ul>
<p><i>Sub-sampling techniques and sample preparation</i></p>	<ul style="list-style-type: none"> <li><i>If core, whether cut or sawn and whether quarter, half or all core taken.</i></li> <li><i>If non-core, whether riffled, tube sampled, rotary split, etc and whether sampled wet or dry.</i></li> <li><i>For all sample types, the nature, quality and appropriateness of the sample preparation technique.</i></li> <li><i>Quality control procedures adopted for all sub-sampling stages to maximise representivity of samples.</i></li> <li><i>Measures taken to ensure that the sampling is representative of the in situ material collected, including for instance results for field duplicate/second-half sampling.</i></li> <li><i>Whether sample sizes are appropriate to the grain size of the material being sampled.</i></li> </ul>	<ul style="list-style-type: none"> <li>A set of standard operating procedures for drilling and sampling were prepared by AKORA and Vato Consulting, who supervised the drilling programme.</li> <li>All core was fitted together so that a consistent half core could be collected, marked up with a consistent “top” line (line perpendicular to dip and strike, or main foliation) to minimise any bias in the samples. Sample intervals were nominally 1m lengths but truncated by lithological, mineralisation, or structural boundaries.</li> <li>Competent core was split using a core saw whereas incompetent/weathered core was split using hammer and chisel. Sampling equipment was cleaned between samples to minimise the risk of cross contamination.</li> <li>Half core samples were collected into polythene bags along with a paper sample tag. This was then sealed using a cable tie and placed into a second polythene bag with a second paper sample tag and sealed using staples. The remaining half core was kept as a reference sample.</li> <li>The samples were subsequently transferred at regular intervals to the sample preparation facility in Antananarivo (OMNIS) where the following procedures took place: <ul style="list-style-type: none"> <li>Sorting and weighing of samples.</li> <li>Dried at 110°C-120°C until totally dry.</li> <li>Weighing after drying.</li> <li>Jaw crushing to 2mm.</li> <li>Samples are passed through a riffle splitter twice (1:1) to produce a ¼ sample.</li> <li>For selected samples, 100g sub-sample was collected for Davis Tube Recovery.</li> <li>Sub-samples are riffle split to collect 100g with 80% passing 2mm and pulverized to 85% passing 75 microns.</li> <li>The ring mill is cleaned using air and silica chips between samples.</li> <li>Reject pulp samples are stored or used as duplicate samples.</li> <li>A measurement of pXRF is taken on selected pulp samples.</li> </ul> </li> <li>Weight of each sub-sample (-2mm and 2 x -75 microns) are recorded and stored in separate boxes for recovery.</li> <li>All sampling methods and sample sizes are deemed appropriate.</li> </ul>

For personal use only

Criteria	JORC Code explanation	Commentary
<p><i>Quality of assay data and laboratory tests</i></p>	<ul style="list-style-type: none"> <li><i>The nature, quality and appropriateness of the assaying and laboratory procedures used and whether the technique is considered partial or total.</i></li> <li><i>For geophysical tools, spectrometers, handheld XRF instruments, etc, the parameters used in determining the analysis including instrument make and model, reading times, calibrations factors applied and their derivation, etc.</i></li> <li><i>Nature of quality control procedures adopted (eg standards, blanks, duplicates, external laboratory checks) and whether acceptable levels of accuracy (ie lack of bias) and precision have been established.</i></li> </ul>	<ul style="list-style-type: none"> <li>Samples from the 2020 drilling campaign were either sent to ALS Iron Ore Technical Centre in Perth, or ALS geochemistry laboratory in Galway Ireland. All samples from 2021 and 2022 were sent to ALS in Perth. Both laboratories are accredited ISO/IEC 17025:2017.</li> <li>Handheld XRF used by AKORA is the Bruker Titan S1 handheld pXRF. The machine was calibrated by the GeoExploration in January 2021 and included QA/QC samples of blanks and two standards.</li> <li>Analysis at ALS was completed on 100g of pulverised sample with 85% passing 75 microns by ME-XRF21u (un-normalised) for total Fe% and multi element analysis including Al<sub>2</sub>O<sub>3</sub>, SiO<sub>2</sub>, P, S, K<sub>2</sub>O, MgO, Mn, Ni, Pb, Sn, Sr, TiO<sub>2</sub>, V, Zn and Zr.</li> <li>Loss on Ignition (OA-GRA05x) was included at 371°C, 650°C, and 1000°C.</li> <li>Selected mineralised samples were subjected to Davis Tube Recovery (DTT). This included a total of 2,178 samples at Bekisopa South. The DTT concentrate was used to determine concentrate grades of relevant elements including Fe, SiO<sub>2</sub>, P, S, Al<sub>2</sub>O<sub>3</sub>, TiO<sub>2</sub>, and LOI. DTT mass Recovery was also reported as a percentage of the measured feed.</li> <li>QC samples consisted of blank samples, pulp duplicates and certified reference materials (CRM) submitted both by AKORA and internally by ALS. CRM and blank samples were included every 40<sup>th</sup> sample with two to four pulp duplicates included every 100 samples.</li> <li>Blank samples submitted by AKORA included silica chips manufactured by African Mineral Standards (AMIS0052, AMIS0439, AMIS0681, and AMIS0793) which have trace amounts of Fe, all below 1%. All blank samples, including the ALS internal blanks, performed well with all samples returning &lt;1% Fe showing no signs of significant contamination between samples.</li> <li>A total of 5 CRMs were submitted by AKORA across the various drilling campaigns. The accuracy of analysis was measured against ±2 and ±3 standard deviations. Any samples reporting assays outside ±3 standard deviations were re-sampled, including 5 samples either side in the batch, and the subsequent results were updated in the assay database. AKORA’s CRM performance is within acceptable levels and therefore accuracy of assays is within acceptable limits and no major bias is observed.</li> <li>A total of 5 CRMs were submitted by ALS as part of their internal QA/QC procedures during the 2022 drilling programme. The results were reviewed by WAI and most CRM values reported assays within acceptable limits. Two CRMs reported several failures, and this is currently being investigated by AKORA.</li> <li>Pulp duplicate samples were assessed based on Half Absolute Relative Difference (HARD) acceptance criteria which includes 90% of the sample population being less than 10% HARD value. A total of 100% of pulp duplicate samples were within the acceptable criteria and therefore the assaying is considered to have a high level of precision.</li> </ul>

For personal use only

Criteria	JORC Code explanation	Commentary
<i>Verification of sampling and assaying</i>	<ul style="list-style-type: none"> <li><i>The verification of significant intersections by either independent or alternative company personnel.</i></li> <li><i>The use of twinned holes.</i></li> <li><i>Documentation of primary data, data entry procedures, data verification, data storage (physical and electronic) protocols.</i></li> <li><i>Discuss any adjustment to assay data.</i></li> </ul>	<ul style="list-style-type: none"> <li>Significant intersections have not been independently verified.</li> <li>Twinned holes were not deliberately drilled however closely spaced re-drilled holes were analysed and showed that downhole grades generally correlated downhole.</li> <li>Primary logging data is collected on hard copy logging sheets which are checked by consultants Vato Consulting and transferred to a Microsoft Excel database. Assay data, including QA/QC, received from the laboratory is also checked on site before being entered into a Microsoft Excel database.</li> <li>No adjustments were made to the assay data.</li> </ul>
<i>Location of data points</i>	<ul style="list-style-type: none"> <li><i>Accuracy and quality of surveys used to locate drill holes (collar and down-hole surveys), trenches, mine workings and other locations used in Mineral Resource estimation.</i></li> <li><i>Specification of the grid system used.</i></li> <li><i>Quality and adequacy of topographic control.</i></li> </ul>	<ul style="list-style-type: none"> <li>All drill hole collars have been provisionally located using a hand-held GPS (+/- 5m accuracy) and then subsequently surveyed by DGPS.</li> <li>WAI were able to verify the position of 18 drill collars at Bekisopa South during a site visit in 2023 with a hand-held GPS.</li> <li>The grid system used is UTM, WGS84, Zone 38 Southern Hemisphere.</li> <li>An accurate topographic survey was completed by FuturMap, a local surveying consultant. The survey was conducted using a PHANTOM 4 Pro type drone, and a pair of Leica System 1200 dual frequency GPS. An accuracy of 10mm horizontal and 20mm vertical is quoted.</li> </ul>
<i>Data spacing and distribution</i>	<ul style="list-style-type: none"> <li><i>Data spacing for reporting of Exploration Results.</i></li> <li><i>Whether the data spacing and distribution is sufficient to establish the degree of geological and grade continuity appropriate for the Mineral Resource and Ore Reserve estimation procedure(s) and classifications applied.</i></li> <li><i>Whether sample compositing has been applied.</i></li> </ul>	<ul style="list-style-type: none"> <li>Data spacing at Bekisopa South is nominally 100m x 150m in areas of deeper drillholes while shallow DSO zones have been drilled at a spacing of 50m x 50m.</li> <li>The data spacing and distribution is considered appropriate to establish geological and grade continuity for the style of mineralisation, particularly within DSO mineralisation and the classification of Mineral Resources.</li> <li>Downhole surveys were conducted every 10m downhole in 2020-2021 drilling at Bekisopa South. All drill holes are within 5° of their planned inclination and within 10° of the planned azimuths, except for BEKD061 which was within 15° of the planned azimuth.</li> <li>No down hole surveys were conducted for 2022 drilling as drillholes were shallow (&lt;30m) and vertical.</li> <li>No sample compositing was applied.</li> </ul>
<i>Orientation of data in relation to</i>	<ul style="list-style-type: none"> <li><i>Whether the orientation of sampling achieves unbiased sampling of possible structures and the extent to which this is known, considering the deposit type.</i></li> <li><i>If the relationship between the drilling</i></li> </ul>	<ul style="list-style-type: none"> <li>The ironstone unit has a strong north-south trend with outcrops, trenches, and magnetics showing a steep to shallow westerly dip. Drilling in 2020 and 2021 is dominantly orientated east, perpendicular to interpreted mineralisation and considered to be optimal.</li> <li>Drilling in 2022 is vertical which targets tabular sub-horizontal DSO mineralisation and considered optimal for this style of mineralisation.</li> </ul>

For personal use only

Criteria	JORC Code explanation	Commentary
<i>geological structure</i>	<i>orientation and the orientation of key mineralised structures is considered to have introduced a sampling bias, this should be assessed and reported if material.</i>	<ul style="list-style-type: none"> <li>The current structural interpretation is an orocline controlling sheet-like mineralisation. A single hole orientated to the west in the far south of the tenement suggests the sequence is dipping east here, suggesting an anticlinal structure in this area.</li> <li>No sample bias is evident.</li> </ul>
<i>Sample security</i>	<ul style="list-style-type: none"> <li><i>The measures taken to ensure sample security.</i></li> </ul>	<ul style="list-style-type: none"> <li>Chain of Custody procedures are implemented to document the possession of the samples from collection to storage, customs, export, analysis, and reporting of results. The Chain of Custody forms are permanent records of sample handling and off-site dispatch.</li> <li>The on-site Geologist is responsible for the care and security of the samples from the sample collection to the export stages. Samples prepared are stored in the preparation facility in labelled sealed plastic bags.</li> <li>The Chain of Custody form contains the following the information: <ul style="list-style-type: none"> <li>Sample identification numbers;</li> <li>Type of sample;</li> <li>Date of sampling;</li> <li>List of analyses required;</li> <li>Customs approval;</li> <li>Waybill number;</li> <li>Name and signature of sampling personnel;</li> <li>Transfer of custody acknowledgement.</li> </ul> </li> <li>Samples are delivered to the analytical laboratory by courier. A copy of the Chain of Custody form is signed, dated, and placed in a sealable plastic bag taped on top of the lid of the sample box. Each sample batch is accompanied by a Chain of Custody form.</li> <li>One box of samples was incorrectly sent to ALS Ireland, and one sent to Perth. The laboratory in Ireland subsequently sent the sample box to Perth where both boxes of samples were analysed. No tampering of either box was reported to have been observed.</li> </ul>
<i>Audits or reviews</i>	<ul style="list-style-type: none"> <li><i>The results of any audits or reviews of sampling techniques and data.</i></li> </ul>	<ul style="list-style-type: none"> <li>No external audits of the sampling and assaying techniques have been carried out.</li> <li>As part of this MRE, WAI has reviewed the documented practices employed by AKORA and their consultant Vato Consulting with respect to diamond drilling, sampling, QA/QC, and assaying, and believe that the processes are appropriate, and that the data is of reasonable quality and suitable for use in Mineral Resource estimation.</li> </ul>

## Section 2 Reporting of Exploration Results

Criteria	JORC Code explanation	Commentary
<i>Mineral tenement and land tenure status</i>	<ul style="list-style-type: none"> <li>Type, reference name/number, location and ownership including agreements or material issues with third parties such as joint ventures, partnerships, overriding royalties, native title interests, historical sites, wilderness or national park and environmental settings.</li> <li>The security of the tenure held at the time of reporting along with any known impediments to obtaining a licence to operate in the area.</li> </ul>	<ul style="list-style-type: none"> <li>The Company completed the acquisition of the minority interest in Iron Ore Corporation of Madagascar sarl held by Cline Mining Corporation on 5 August 2020.</li> <li>The licenses that comprise the overall Bekisopa Project (inclusive of Northern, Central and Southern areas) consist of one granted research permit (PR 10430) and one granted small scale mining permit (PRE 3757). Of these, Bekisopa South falls within the PR 10430 licence.</li> <li>Applications to renew the licenses were made by Akora in May 2022 in a timely manner, however, feedback from the authorities is still awaited. It not uncommon in these instances, for renewal applications (even when made timeously and in accordance with the prevailing mining law) to extend beyond anticipated timeframes. The requisite environmental commitment plan for exploration was submitted by Akora to the Direction Générale des Mines on 30<sup>th</sup>March, 2021.</li> </ul>
<i>Exploration done by other parties</i>	<ul style="list-style-type: none"> <li>Acknowledgment and appraisal of exploration by other parties.</li> </ul>	<ul style="list-style-type: none"> <li>Exploration has been conducted by UNDP (1976 - 78) and BRGM (1958 - 62). Final reports on both episodes of work are available and have been utilised in the recent IGR included in the AKORA prospectus. Airborne magnetics was flown for the government by Fugro and has since been obtained, modelled, and interpreted by Cline Mining and AKORA.</li> </ul>
<i>Geology</i>	<ul style="list-style-type: none"> <li>Deposit type, geological setting and style of mineralisation.</li> </ul>	<ul style="list-style-type: none"> <li>The tenure was acquired by AKORA during 2014 and work since then has consisted of: <ul style="list-style-type: none"> <li>Data compilation and interpretation;</li> <li>Confirmatory rock chip sampling (118 samples) and mapping;</li> <li>Re-interpretation of airborne geophysical data;</li> <li>Ground magnetic surveying (305 line kilometres);</li> <li>The 2020 – 2022 drilling programme of 7,378m diamond core drilling from 150 drillholes, with 4,816m diamond core drilling in 123 holes at Bekisopa South.</li> </ul> </li> <li>The mineralisation occurs as a series of magnetite bearing gneisses and calc-silicates that occur as zones between 50m and 150m combined true width.</li> <li>The mineralisation occurs as layers of massive magnetite (sometimes altered to hematite) between 1m and 7m true widths plus a lower grade zone that consists of lenses, stringers, boudins and blebs of magnetite aggregates that vary from 1cm to 10's of cm wide within a calc-silicate/gneiss unit (informally termed "coarse disseminated" here). These units sometimes have an outer halo of finer disseminated magnetite (informally termed "disseminated" here).</li> <li>Infill drilling at Bekisopa South has confirmed DSO mineralisation, which is interpreted as eastern and western zones, coupled with the 6km-7km strike of mapped mineralisation and magnetic anomaly within</li> </ul>

For personal use only

Criteria	JORC Code explanation	Commentary
		<p>the AKORA tenement suggests a large potential tonnage. The recent drilling has shown that the surface mineralisation continues at depth.</p> <ul style="list-style-type: none"> <li>The bands and blebs of massive magnetite aggregates along with preliminary LIMS testwork suggest that a good iron product may be obtained using a simple crush to -2mm followed by magnetic separation.</li> </ul>
<i>Drill hole Information</i>	<ul style="list-style-type: none"> <li><i>A summary of all information material to the understanding of the exploration results including a tabulation of the following information for all Material drill holes:</i> <ul style="list-style-type: none"> <li><i>easting and northing of the drill hole collar</i></li> <li><i>elevation or RL (Reduced Level – elevation above sea level in metres) of the drill hole collar</i></li> <li><i>dip and azimuth of the hole</i></li> <li><i>down hole length and interception depth</i></li> <li><i>hole length.</i></li> </ul> </li> <li><i>If the exclusion of this information is justified on the basis that the information is not Material and this exclusion does not detract from the understanding of the report, the Competent Person should clearly explain why this is the case.</i></li> </ul>	<ul style="list-style-type: none"> <li>All drill information being reported as part of this announcement can be found on the Company’s website and specifically the announcements released to the ASX on 14 Sep 2021, 27 Sep 2021, 19 Oct 2021, 3 Nov 2021, 9 Nov 2021, 17 Nov 2021, 11 Jan 2022, 28 Jan 2022, 2 Mar 2022, and 22 March 2023.</li> <li>Assays were conducted at ALS Laboratory in Perth, WA. DTT and wLIMS testwork was conducted by ALS Iron Ore facility in Perth, WA.</li> <li>Only data from Bekisopa South was used for this Mineral Resource estimate. No data from Bekisopa South was excluded.</li> <li>A plan of the drillholes at Bekisopa South is contained in the main body of the report.</li> </ul>
<i>Data aggregation methods</i>	<ul style="list-style-type: none"> <li><i>In reporting Exploration Results, weighting averaging techniques, maximum and/or minimum grade truncations (eg cutting of high grades) and cut-off grades are</i></li> </ul>	<ul style="list-style-type: none"> <li>No top-cuts to the data were required.</li> <li>No metal equivalent equations were used during the Mineral Resource estimation procedure or reporting.</li> <li>Samples were composited to 1m lengths during the Mineral Resource estimation procedure to ensure a consistent level of support during the estimation process.</li> </ul>

For personal use only

Criteria	JORC Code explanation	Commentary
	<p><i>usually Material and should be stated.</i></p> <ul style="list-style-type: none"> <li>• <i>Where aggregate intercepts incorporate short lengths of high grade results and longer lengths of low grade results, the procedure used for such aggregation should be stated and some typical examples of such aggregations should be shown in detail.</i></li> <li>• <i>The assumptions used for any reporting of metal equivalent values should be clearly stated.</i></li> </ul>	
<i>Relationship between mineralisation widths and intercept lengths</i>	<ul style="list-style-type: none"> <li>• <i>These relationships are particularly important in the reporting of Exploration Results.</i></li> <li>• <i>If the geometry of the mineralisation with respect to the drill hole angle is known, its nature should be reported.</i></li> <li>• <i>If it is not known and only the down hole lengths are reported, there should be a clear statement to this effect (eg 'down hole length, true width not known').</i></li> </ul>	<ul style="list-style-type: none"> <li>• DSO mineralisation is interpreted to be tabular and horizontal therefore vertical drilling is orthogonal to mineralisation.</li> <li>• Deeper mineralisation is interpreted to dip to the west, therefore drillholes have been drilled with a easty dip to intersect mineralisation orthogonally.</li> </ul>
<i>Diagrams</i>	<ul style="list-style-type: none"> <li>• <i>Appropriate maps and sections (with scales) and tabulations of intercepts should be included for any significant discovery being reported These should include, but not be limited to a plan view of drill hole collar locations and appropriate sectional views.</i></li> </ul>	<ul style="list-style-type: none"> <li>• Appropriate data tabulations are included in the main body of the report.</li> </ul>

Criteria	JORC Code explanation	Commentary
<i>Balanced reporting</i>	<ul style="list-style-type: none"> <li>Where comprehensive reporting of all Exploration Results is not practicable, representative reporting of both low and high grades and/or widths should be practiced to avoid misleading reporting of Exploration Results.</li> </ul>	<ul style="list-style-type: none"> <li>Statistics of drill hole grades used in the MRE are contained in the main body of the report.</li> </ul>
<i>Other substantive exploration data</i>	<ul style="list-style-type: none"> <li>Other exploration data, if meaningful and material, should be reported including (but not limited to): geological observations; geophysical survey results; geochemical survey results; bulk samples – size and method of treatment; metallurgical test results; bulk density, groundwater, geotechnical and rock characteristics; potential deleterious or contaminating substances.</li> </ul>	<ul style="list-style-type: none"> <li>Akora has completed ground geophysical surveys using international suppliers. This clearly defines the iron rich mineralisation and was used as a guide to planning drillholes.</li> </ul>
<i>Further work</i>	<ul style="list-style-type: none"> <li>The nature and scale of planned further work (eg tests for lateral extensions or depth extensions or large-scale step-out drilling).</li> <li>Diagrams clearly highlighting the areas of possible extensions, including the main geological interpretations and future drilling areas, provided this information is not commercially sensitive.</li> </ul>	<ul style="list-style-type: none"> <li>WAI understands that Akora is planning to undertake some additional short drillholes into the DSO zones at Bekisopa South during 2023. WAI is not aware of any further details of this.</li> </ul>

### Section 3 Estimation and Reporting of Mineral Resources

Criteria	JORC Code explanation	Commentary
<i>Database integrity</i>	<ul style="list-style-type: none"> <li>Measures taken to ensure that data has not been corrupted by, for example, transcription or keying errors, between its initial collection and its use for Mineral Resource estimation purposes.</li> <li>Data validation procedures used.</li> </ul>	<ul style="list-style-type: none"> <li>Validation of the database is undertaken by Akora personnel and its consultants/contractors.</li> <li>The database consists of individual Microsoft Excel sheets containing all relevant exploration data.</li> <li>All data is manually entered to Microsoft Excel sheets from hard copy logging, or in cases of geophysical data, downloaded from the relevant machine and uploaded to the database.</li> <li>Database validation conducted by WAI for this MRE included: <ul style="list-style-type: none"> <li>Ensuring drillhole collars have valid coordinates, coincide within expected limits and correlate with topographical surfaces;</li> <li>Checking for the presence of duplicate drillhole collar IDs and coordinates;</li> <li>Ensuring all holes have valid downhole surveys and have consistent values;</li> <li>Ensuring assays, density measurements or logging information is present.</li> <li>Checking for overlapping, duplicate, or absent assay values;</li> <li>Checking minimum and maximum values for grades and density to ensure they are within expected limits;</li> <li>Identify sample intervals where grade has been recorded over an excessive length;</li> <li>Assessing for inconsistencies in spelling or coding to ensure consistency in data review.</li> </ul> </li> </ul>
<i>Site visits</i>	<ul style="list-style-type: none"> <li>Comment on any site visits undertaken by the Competent Person and the outcome of those visits.</li> <li>If no site visits have been undertaken indicate why this is the case.</li> </ul>	<ul style="list-style-type: none"> <li>A site visit was conducted by Mr Robin Kelly on the 7<sup>th</sup> May, 2023. During the visit, Bekisopa North, Central and South zones were visited, outcrops observed, DSO scree observed and select drill collars visited and their co-ordinates verified.</li> <li>Mr Robin Kelly also visited the core storage facility in Antananarivo on the 10<sup>th</sup> May, 2023. Multiple drillholes were observed and original logs and assay results briefly compared. Drillholes observed included: <ul style="list-style-type: none"> <li>BEKD044</li> <li>BEKD045</li> <li>BEKD067</li> <li>BEKD092</li> <li>BEK121</li> <li>BEK126</li> <li>BEKD132</li> </ul> </li> </ul>
<i>Geological interpretation</i>	<ul style="list-style-type: none"> <li>Confidence in (or conversely, the uncertainty of) the geological interpretation of the mineral deposit.</li> </ul>	<ul style="list-style-type: none"> <li>The broad geological interpretation of the Bekisopa deposit is relatively straightforward and moderately constrained by drilling, surface mapping and the high amplitude airborne and ground</li> </ul>

For personal use only

Criteria	JORC Code explanation	Commentary
	<ul style="list-style-type: none"> <li>• <i>Nature of the data used and of any assumptions made.</i></li> <li>• <i>The effect, if any, of alternative interpretations on Mineral Resource estimation.</i></li> <li>• <i>The use of geology in guiding and controlling Mineral Resource estimation.</i></li> <li>• <i>The factors affecting continuity both of grade and geology.</i></li> </ul>	<p>magnetic anomalies.</p> <ul style="list-style-type: none"> <li>• DSO material is relatively discrete and well constrained.</li> <li>• The main iron mineralisation comprises a series of parallel layers of massive magnetite (+/-hematite), within magnetite bearing gneiss. Mineralisation appears to be stratabound and is thought to be a replacement of carbonate/calc silicate units intermixed with gneissic-schist material.</li> <li>• The deposit is thought to be replacive (skarn), the distribution of original calc-silicate host lithology will be a major control of grade continuity. Skarns are notorious for variable grade continuity.</li> <li>• Additional work is required to further the understanding of the geological model, structural interpretation and grade variability at Bekisopa South. In addition, the relationship between the western and eastern DSO zones is currently unknown and further geological studies will be required to determine this.</li> <li>• WAI generated solid wireframes for the DSO zones based on a nominal cut-off grade of 58% Fe. DSO material is predominantly hosted in the regolith, although minor amounts of less weathered material have also been captured within these wireframe zones.</li> <li>• For the Green Steel zone, a 25% cut-off grade was used to define the wireframes of the mineralisation. Due to the varied lithological nature of the Fe mineralisation within these interbedded metamorphic units, modelling was completed using assay values only.</li> </ul>
<i>Dimensions</i>	<ul style="list-style-type: none"> <li>• <i>The extent and variability of the Mineral Resource expressed as length (along strike or otherwise), plan width, and depth below surface to the upper and lower limits of the Mineral Resource.</i></li> </ul>	<ul style="list-style-type: none"> <li>• The Mineral Resource Estimate was completed on the Bekisopa South target only.</li> <li>• The mineralisation at Bekisopa South consists of two near surface DSO mineralisation packages with a deeper zone of mineralisation termed the "Green Steel" zone . <ul style="list-style-type: none"> <li>○ DSO West – strike length of 675m, width of 25-200m and depth of up to 25m, orientated North to South and is flat lying.</li> <li>○ DSO East – strike length of 1,000m, width of 150-320m and depth of up to 30m, orientated Northeast to Southwest and dipping 5° to the northwest.</li> <li>○ Green Steel zone – strike length of 750m, width of 320-575m and depth of up to 210m, orientated Northeast to Southwest and dipping 20° to the northwest.</li> </ul> </li> </ul>
<i>Estimation and modelling techniques</i>	<ul style="list-style-type: none"> <li>• <i>The nature and appropriateness of the estimation technique(s) applied and key assumptions, including treatment of extreme grade values, domaining, interpolation parameters and maximum distance of extrapolation from data</i></li> </ul>	<ul style="list-style-type: none"> <li>• Variogram models for Fe, Al<sub>2</sub>O<sub>3</sub>, Mn, P, S, SiO<sub>2</sub> and TiO<sub>2</sub> were constructed based on composite data after normal score transformation, however, well-structured variograms were not able to be created.</li> <li>• Inverse Distance Weighting ("IDW") was therefore used as the principal estimation methodology. Nearest Neighbour estimates were carried out for validation purposes.</li> <li>• A block size of 20m (X) x 20m (Y) x 5m (Z) was used for grade estimation. The smallest drill spacing at Bekisopa South is 50m x 50m in the DSO zones. Estimation was carried out into parent cells only. Search</li> </ul>

For personal use only

Criteria	JORC Code explanation	Commentary																																																																																								
	<p><i>points. If a computer assisted estimation method was chosen include a description of computer software and parameters used.</i></p> <ul style="list-style-type: none"> <li><i>The availability of check estimates, previous estimates and/or mine production records and whether the Mineral Resource estimate takes appropriate account of such data.</i></li> <li><i>The assumptions made regarding recovery of by-products.</i></li> <li><i>Estimation of deleterious elements or other non-grade variables of economic significance (eg sulphur for acid mine drainage characterisation).</i></li> <li><i>In the case of block model interpolation, the block size in relation to the average sample spacing and the search employed.</i></li> <li><i>Any assumptions behind modelling of selective mining units.</i></li> <li><i>Any assumptions about correlation between variables.</i></li> <li><i>Description of how the geological interpretation was used to control the resource estimates.</i></li> <li><i>Discussion of basis for using or not using grade cutting or capping.</i></li> <li><i>The process of validation, the checking process used, the comparison of model data to drill hole data, and use of reconciliation data if available.</i></li> </ul>	<p>parameters used in the estimation are detailed in the main body of the report. A total of 2,145 composites were used in the estimation of MINDOMs 1 to 7.</p> <table border="1" style="width: 100%; border-collapse: collapse; text-align: center;"> <thead> <tr> <th colspan="8">Estimation Parameters</th> </tr> <tr> <th rowspan="2">MINDOM</th> <th rowspan="2">Search</th> <th colspan="3">Search Distance (m)</th> <th colspan="2">Composites</th> <th>Drillholes</th> </tr> <tr> <th>Down Dip</th> <th>Along Strike</th> <th>Across Strike</th> <th>Minimum</th> <th>Maximum</th> <th>Minimum</th> </tr> </thead> <tbody> <tr> <td rowspan="3">1</td> <td>1<sup>st</sup></td> <td>50</td> <td>75</td> <td>10</td> <td>11</td> <td>22</td> <td>2</td> </tr> <tr> <td>2<sup>nd</sup></td> <td>100</td> <td>150</td> <td>20</td> <td>11</td> <td>22</td> <td>2</td> </tr> <tr> <td>3<sup>rd</sup></td> <td>150</td> <td>225</td> <td>30</td> <td>2</td> <td>20</td> <td>1</td> </tr> <tr> <td rowspan="3">2</td> <td>1<sup>st</sup></td> <td>50</td> <td>75</td> <td>10</td> <td>11</td> <td>22</td> <td>2</td> </tr> <tr> <td>2<sup>nd</sup></td> <td>100</td> <td>150</td> <td>20</td> <td>11</td> <td>22</td> <td>2</td> </tr> <tr> <td>3<sup>rd</sup></td> <td>150</td> <td>225</td> <td>30</td> <td>2</td> <td>20</td> <td>1</td> </tr> <tr> <td rowspan="3">3</td> <td>1<sup>st</sup></td> <td>50</td> <td>75</td> <td>15</td> <td>11</td> <td>22</td> <td>2</td> </tr> <tr> <td>2<sup>nd</sup></td> <td>100</td> <td>150</td> <td>30</td> <td>11</td> <td>22</td> <td>2</td> </tr> <tr> <td>3<sup>rd</sup></td> <td>150</td> <td>225</td> <td>45</td> <td>2</td> <td>20</td> <td>1</td> </tr> </tbody> </table> <p>Notes:  MINDOM 1 orientation – down dip: east-west; along strike: north-south;  MINDOM 2 orientation – down dip: -5 degree dip to 305 degrees azimuth; along strike: 35 degrees azimuth;  MINDOM 2 orientation – down dip: -20 degree dip to 305 degrees azimuth; along strike: 35 degrees azimuth;  (MINDOM 1 search used for MINDOMs 5, 6 and 7)  (MINDOM 2 search used for MINDOM 4)  Maxkey of 10 composites per drillhole</p> <ul style="list-style-type: none"> <li>Grades were estimated into the defined mineralised zones (MINDOM keyfield) which were treated as hard boundaries.</li> <li>Density values (derived from the regression of Fe grades after subdivision by weathering type) were estimated into the mineralised zones based on weathering type (DENSDOM keyfield).</li> <li>Grades and density values were estimated into the block model using Datamine software.</li> <li>Davis Tube Test (“DTT”) results of the recovered magnetic fraction were included in the block model for the Green Steel zone (MINDOM 3) by regressing the estimated Fe block grades based on weathering type. Regression formulas were derived for each weathering type using a total of 1,068 DTT results with corresponding Fe results.</li> <li>Potentially deleterious elements (Al<sub>2</sub>O<sub>3</sub>, Mn, P, SiO<sub>2</sub> and TiO<sub>2</sub>) were estimated into the block model. Sulphur (S) was not estimated as an upper assay detection limit of 5.0% S is present in the assays in the database. It is recommended that these values are re-assayed using a different method with a higher</li> </ul>	Estimation Parameters								MINDOM	Search	Search Distance (m)			Composites		Drillholes	Down Dip	Along Strike	Across Strike	Minimum	Maximum	Minimum	1	1 <sup>st</sup>	50	75	10	11	22	2	2 <sup>nd</sup>	100	150	20	11	22	2	3 <sup>rd</sup>	150	225	30	2	20	1	2	1 <sup>st</sup>	50	75	10	11	22	2	2 <sup>nd</sup>	100	150	20	11	22	2	3 <sup>rd</sup>	150	225	30	2	20	1	3	1 <sup>st</sup>	50	75	15	11	22	2	2 <sup>nd</sup>	100	150	30	11	22	2	3 <sup>rd</sup>	150	225	45	2	20	1
Estimation Parameters																																																																																										
MINDOM	Search	Search Distance (m)			Composites		Drillholes																																																																																			
		Down Dip	Along Strike	Across Strike	Minimum	Maximum	Minimum																																																																																			
1	1 <sup>st</sup>	50	75	10	11	22	2																																																																																			
	2 <sup>nd</sup>	100	150	20	11	22	2																																																																																			
	3 <sup>rd</sup>	150	225	30	2	20	1																																																																																			
2	1 <sup>st</sup>	50	75	10	11	22	2																																																																																			
	2 <sup>nd</sup>	100	150	20	11	22	2																																																																																			
	3 <sup>rd</sup>	150	225	30	2	20	1																																																																																			
3	1 <sup>st</sup>	50	75	15	11	22	2																																																																																			
	2 <sup>nd</sup>	100	150	30	11	22	2																																																																																			
	3 <sup>rd</sup>	150	225	45	2	20	1																																																																																			

For personal use only

Criteria	JORC Code explanation	Commentary																																																			
		<p>detection limit prior to estimation of S in the block model.</p> <ul style="list-style-type: none"> <li>No top-cutting was applied as no extreme values were identified during the geostatistical review.</li> <li>Estimation of grades and density within the block model was verified visually and appears to represent the grades within the drillholes and composites. WAI also completed a statistical analysis of the block model comparison against the composited drillhole data, along with Swath plots, which show a good correlation with the original drillhole data.</li> <li>The deposit has not been mined and so there is no reconciliation data.</li> </ul>																																																			
Moisture	<ul style="list-style-type: none"> <li>Whether the tonnages are estimated on a dry basis or with natural moisture, and the method of determination of the moisture content.</li> </ul>	<ul style="list-style-type: none"> <li>Tonnages of the Mineral Resources are estimated on a dry weight basis.</li> </ul>																																																			
Cut-off parameters	<ul style="list-style-type: none"> <li>The basis of the adopted cut-off grade(s) or quality parameters applied.</li> </ul>	<ul style="list-style-type: none"> <li>No cut-off applied for DSO.</li> <li>Cut-off grade of 36% Fe applied to the Green Steel zone to give a head grade of 45% Fe (based on the Scoping Study (October 2022)).</li> </ul>																																																			
Mining factors or assumptions	<ul style="list-style-type: none"> <li>Assumptions made regarding possible mining methods, minimum mining dimensions and internal (or, if applicable, external) mining dilution. It is always necessary as part of the process of determining reasonable prospects for eventual economic extraction to consider potential mining methods, but the assumptions made regarding mining methods and parameters when estimating Mineral Resources may not always be rigorous. Where this is the case, this should be reported with an explanation of the basis of the mining assumptions made.</li> </ul>	<ul style="list-style-type: none"> <li>The MRE has been constrained by an open pit optimisation based on technical and indicative processing costs and long-term product pricing parameters as shown below (based on the October 2022 Scoping Study).</li> </ul> <table border="1" data-bbox="1137 912 1975 1378"> <thead> <tr> <th colspan="4">Akora MRE Constraint Optimisation Parameters</th> </tr> <tr> <th>Parameter</th> <th>Unit</th> <th>DSO Zones</th> <th>Green Steel Zone</th> </tr> </thead> <tbody> <tr> <td>Mining Cost Ore</td> <td>US\$/t</td> <td>2*</td> <td>3*</td> </tr> <tr> <td>Mining Cost Waste</td> <td>US\$/t</td> <td>2*</td> <td>3*</td> </tr> <tr> <td>Re-handling Cost</td> <td>US\$/t</td> <td colspan="2">1.00</td> </tr> <tr> <td rowspan="2">Processing cost</td> <td>US\$/t mined</td> <td>3*</td> <td>10*</td> </tr> <tr> <td>US\$/t conc</td> <td>3*</td> <td>27*</td> </tr> <tr> <td>Transport &amp; Logistics</td> <td>US\$/t conc</td> <td colspan="2">25.00</td> </tr> <tr> <td>G&amp;A</td> <td>US\$/t ore</td> <td colspan="2">0.50</td> </tr> <tr> <td>Royalty Cost</td> <td>%</td> <td colspan="2">4</td> </tr> <tr> <td>Metallurgical Recovery</td> <td>%</td> <td>100</td> <td>54</td> </tr> <tr> <td>Concentrate Grade</td> <td>%Fe</td> <td>67</td> <td>67</td> </tr> <tr> <td>Discount Rate</td> <td>%</td> <td colspan="2">10</td> </tr> </tbody> </table>	Akora MRE Constraint Optimisation Parameters				Parameter	Unit	DSO Zones	Green Steel Zone	Mining Cost Ore	US\$/t	2*	3*	Mining Cost Waste	US\$/t	2*	3*	Re-handling Cost	US\$/t	1.00		Processing cost	US\$/t mined	3*	10*	US\$/t conc	3*	27*	Transport & Logistics	US\$/t conc	25.00		G&A	US\$/t ore	0.50		Royalty Cost	%	4		Metallurgical Recovery	%	100	54	Concentrate Grade	%Fe	67	67	Discount Rate	%	10	
Akora MRE Constraint Optimisation Parameters																																																					
Parameter	Unit	DSO Zones	Green Steel Zone																																																		
Mining Cost Ore	US\$/t	2*	3*																																																		
Mining Cost Waste	US\$/t	2*	3*																																																		
Re-handling Cost	US\$/t	1.00																																																			
Processing cost	US\$/t mined	3*	10*																																																		
	US\$/t conc	3*	27*																																																		
Transport & Logistics	US\$/t conc	25.00																																																			
G&A	US\$/t ore	0.50																																																			
Royalty Cost	%	4																																																			
Metallurgical Recovery	%	100	54																																																		
Concentrate Grade	%Fe	67	67																																																		
Discount Rate	%	10																																																			

For personal use only

Criteria	JORC Code explanation	Commentary																		
		<table border="1" style="margin-left: auto; margin-right: auto;"> <tr> <td>Overall Pit Slope Angles</td> <td>°</td> <td>40</td> </tr> <tr> <td>Mining Recovery</td> <td>%</td> <td>0</td> </tr> <tr> <td>Mining Dilution</td> <td>%</td> <td>0</td> </tr> <tr> <td>62% Fe Conc Price</td> <td>US\$/t conc</td> <td>110*</td> </tr> <tr> <td>65% Fe Conc Price</td> <td>US\$/t conc</td> <td>135*</td> </tr> <tr> <td>67% Fe Conc Price</td> <td>US\$/t conc</td> <td>150*</td> </tr> </table> <p style="text-align: center; font-size: small;">* Estimated long-term rounded costs and product prices for optimisation purposes</p> <ul style="list-style-type: none"> <li>The low grade mineralized zones (MINDOMs 4, 5, 6 and 7) and the highly weathered portion of the Green Steel zone (MINDOM 3) were also included in the optimization process and used the parameters for the Green Steel zone shown in the table above. These zones, however, were excluded from the final Mineral Resource statement as they are not currently considered by Akora as part of the Bekisopa Project due to lower Fe grades or higher levels of impurities.</li> </ul>	Overall Pit Slope Angles	°	40	Mining Recovery	%	0	Mining Dilution	%	0	62% Fe Conc Price	US\$/t conc	110*	65% Fe Conc Price	US\$/t conc	135*	67% Fe Conc Price	US\$/t conc	150*
Overall Pit Slope Angles	°	40																		
Mining Recovery	%	0																		
Mining Dilution	%	0																		
62% Fe Conc Price	US\$/t conc	110*																		
65% Fe Conc Price	US\$/t conc	135*																		
67% Fe Conc Price	US\$/t conc	150*																		
<i>Metallurgical factors or assumptions</i>	<ul style="list-style-type: none"> <li><i>The basis for assumptions or predictions regarding metallurgical amenability. It is always necessary as part of the process of determining reasonable prospects for eventual economic extraction to consider potential metallurgical methods, but the assumptions regarding metallurgical treatment processes and parameters made when reporting Mineral Resources may not always be rigorous. Where this is the case, this should be reported with an explanation of the basis of the metallurgical assumptions made.</i></li> </ul>	<ul style="list-style-type: none"> <li>The DSO will be processed by crushing and screening to produce conventional lump and fines products.</li> <li>The green steel material flowsheet (based on the October 2022 Scoping Study) includes:             <ol style="list-style-type: none"> <li>Wet grinding to 75-micron size and wet high intensity magnetic separation;</li> <li>Davis Tube Testing (DTT) on assay pulp ground samples, at a typical P80 of 75 microns, delivered iron concentrate grades averaging 68.4% Fe from head grades &gt;45% Fe and with a mass recovery of 54% for a specific composite sample.</li> </ol> </li> <li>An updated Scoping Study is planned by Akora in 2023 and will incorporate additional DTT recovery information not included in the October 2022 Scoping Study.</li> </ul>																		
<i>Environmental factors or assumptions</i>	<ul style="list-style-type: none"> <li><i>Assumptions made regarding possible waste and process residue disposal options. It is always necessary as part of the process of determining reasonable prospects for eventual economic extraction to consider the</i></li> </ul>	<ul style="list-style-type: none"> <li>The deposit lies within flat to lightly undulating, isolated open country in south central rural Madagascar, predominately scrubby grassland with occasional small trees.</li> <li>There are large flat areas for waste and tailings disposal.</li> <li>A small number of creeks with only seasonal flows are also present.</li> </ul>																		

For personal use only

Criteria	JORC Code explanation	Commentary
	<p><i>potential environmental impacts of the mining and processing operation. While at this stage the determination of potential environmental impacts, particularly for a greenfields project, may not always be well advanced, the status of early consideration of these potential environmental impacts should be reported. Where these aspects have not been considered this should be reported with an explanation of the environmental assumptions made.</i></p>	<ul style="list-style-type: none"> <li>WAI is not aware of any waste storage, environmental or permitting issues that prevent the reporting of a Mineral Resource Estimate for the Bekisopa South Iron deposit.</li> </ul>
<p><b>Bulk density</b></p>	<ul style="list-style-type: none"> <li><i>Whether assumed or determined. If assumed, the basis for the assumptions. If determined, the method used, whether wet or dry, the frequency of the measurements, the nature, size and representativeness of the samples.</i></li> <li><i>The bulk density for bulk material must have been measured by methods that adequately account for void spaces (vugs, porosity, etc), moisture and differences between rock and alteration zones within the deposit.</i></li> <li><i>Discuss assumptions for bulk density estimates used in the evaluation process of the different materials.</i></li> </ul>	<ul style="list-style-type: none"> <li>Density of samples from Bekisopa South was measured for both fresh rock and regolith/oxidised material on selected sections of core ranging in length between 10cm to 15cm.</li> <li>Samples from fresh rock were measured using the Archimedes Principle (1,448 measurements) and samples from weathered/oxidised rock was measured by Calliper Vernier (2,151 measurements) totally at 3,599 measurements.</li> <li>Voids are rare in the fresh rock material but are more prevalent in the regolith and this requires further testwork to confirm the original density value.</li> <li>Regression equations were developed based on the relationship between Fe grade and density which was subsequently estimated into the block model as detailed in estimation and modelling techniques section. The regression equations used are as follows: <ul style="list-style-type: none"> <li>Domain 110: <math>(0.062 * H\_Fe\_pct) - 0.276</math></li> <li>Domain 120: <math>(0.05 * H\_Fe\_pct) + 1.13</math></li> <li>Domain 210 &lt; 40% Fe: <math>(0.014 * H\_Fe\_pct) + 1.475</math></li> <li>Domain 210 40%-60% Fe: <math>(0.032 * H\_Fe\_pct) + 0.81</math></li> <li>Domain 210 &gt;60%: <math>(0.175 * H\_Fe\_pct) - 7.451</math></li> <li>Domain 220 &lt;60%: <math>(0.04 * H\_Fe\_pct) + 0.613</math></li> <li>Domain 220 &gt;60%: <math>(0.172 * H\_Fe\_pct) - 7.455</math></li> <li>Domain 310: <math>(0.019 * H\_Fe\_pct) + 1.603</math></li> <li>Domain 320: <math>(0.031 * H\_Fe\_pct) + 2.281</math></li> <li>Domain 330: <math>0.038 * H\_Fe\_pct + 2.7</math></li> </ul> </li> </ul>

For personal use only

Criteria	JORC Code explanation	Commentary
<i>Classification</i>	<ul style="list-style-type: none"> <li><i>The basis for the classification of the Mineral Resources into varying confidence categories.</i></li> <li><i>Whether appropriate account has been taken of all relevant factors (ie relative confidence in tonnage/grade estimations, reliability of input data, confidence in continuity of geology and metal values, quality, quantity and distribution of the data).</i></li> <li><i>Whether the result appropriately reflects the Competent Person's view of the deposit.</i></li> </ul>	<ul style="list-style-type: none"> <li>Mineral Resource classification was made following the guidelines of the JORC Code (2012) to Indicated and Inferred status.</li> <li>Classification was based on sample density, confidence in the geological and mineralisation continuity and reliability of the exploration database used as the basis of Mineral Resource estimation.</li> <li>Measured Mineral Resources – Despite the relatively close spaced drilling in areas of Bekisopa South, WAI believes that an absence of an overall geological and structural model precludes the classification of Measured Mineral Resources.</li> <li>Indicated Mineral Resources – Those areas of the DSO zones (MINDOMs 1 and 2) covered by exploration drillholes on a grid of 50m x 50m.</li> <li>Inferred Mineral Resources: <ul style="list-style-type: none"> <li>DSO zones (MINDOMs 1 and 2) - all remaining areas outside of the 50m x 50m spaced grid or where geological complexity is observed.</li> <li>Green Steel zone (MINDOM 3) – the moderately weathered and unweathered portions (including areas covered by deeper drillholes at a spacing of 100m x 150m) were classified as Inferred Mineral Resources. The highly weathered portion of the Green Steel zone was excluded due to higher levels of impurities associated with this zone.</li> </ul> </li> <li>The Mineral Resource Estimate classification reflects the Competent Person's view of the Bekisopa South Iron deposit.</li> </ul>
<i>Audits or reviews</i>	<ul style="list-style-type: none"> <li><i>The results of any audits or reviews of Mineral Resource estimates.</i></li> </ul>	<ul style="list-style-type: none"> <li>WAI is not aware of any audits or reviews of this or any previous Mineral Resource Estimates.</li> </ul>
<i>Discussion of relative accuracy/ confidence</i>	<ul style="list-style-type: none"> <li><i>Where appropriate a statement of the relative accuracy and confidence level in the Mineral Resource estimate using an approach or procedure deemed appropriate by the Competent Person. For example, the application of statistical or geostatistical procedures to quantify the relative accuracy of the resource within stated confidence limits, or, if such an approach is not deemed appropriate, a qualitative discussion of the factors that could</i></li> </ul>	<ul style="list-style-type: none"> <li>The relative accuracy and confidence in the Mineral Resource estimate is reflected in the reporting of the Mineral Resource as set out in the JORC Code (2012).</li> <li>Validation procedures carried out on the final block models against input sample data show good correlation.</li> <li>The statement relates to global estimates of tonnes and grade.</li> <li>Bekisopa South is a greenfield project and no production data is available.</li> </ul>

For personal use only

Criteria	JORC Code explanation	Commentary
	<p><i>affect the relative accuracy and confidence of the estimate.</i></p> <ul style="list-style-type: none"> <li><i>The statement should specify whether it relates to global or local estimates, and, if local, state the relevant tonnages, which should be relevant to technical and economic evaluation. Documentation should include assumptions made and the procedures used.</i></li> <li><i>These statements of relative accuracy and confidence of the estimate should be compared with production data, where available.</i></li> </ul>	

wardell-armstrong.com

ENERGY AND CLIMATE CHANGE  
ENVIRONMENT AND SUSTAINABILITY  
INFRASTRUCTURE AND UTILITIES  
LAND AND PROPERTY  
MINING AND MINERAL PROCESSING  
MINERAL ESTATES  
WASTE RESOURCE MANAGEMENT

For personal use only



**AKORA RESOURCES**

**MINERAL RESOURCE ESTIMATE**

**BEKISOPA SOUTH IRON PROJECT**

**July 2023**



**DATE ISSUED:** 05 July 2023  
**JOB NUMBER:** ZT61-2183  
**VERSION:** V1.0  
**REPORT NUMBER:** MM1648  
**STATUS:** Final

**AKORA RESOURCES**

**MINERAL RESOURCE ESTIMATE**

**BEKISOPA SOUTH IRON PROJECT**

**July 2023**

**PREPARED BY:**

Robin Kelly	Principal Geologist
Joseph O'Neill	Senior Geologist
Richard Ellis	Principal Resource Geologist

**APPROVED BY:**

Mark Kenwright	Associate Director
----------------	--------------------



*This report has been prepared by Wardell Armstrong International with all reasonable skill, care and diligence, within the terms of the Contract with the Client. The report is confidential to the Client and Wardell Armstrong International accepts no responsibility of whatever nature to third parties to whom this report may be made known.*

*No part of this document may be reproduced without the prior written approval of Wardell Armstrong International.*

For personal use only



Wardell Armstrong is the trading name of Wardell Armstrong International Ltd,  
Registered in England No. 3813172.

Registered office: Sir Henry Doulton House, Forge Lane, Etruria, Stoke-on-Trent, ST1 5BD, United Kingdom

UK Offices: Stoke-on-Trent, Birmingham, Bolton, Bristol, Bury St Edmunds, Cardiff, Carlisle, Edinburgh, Glasgow, Leeds, London, Newcastle upon Tyne and Truro. International Office: Almaty.

ENERGY AND CLIMATE CHANGE  
ENVIRONMENT AND SUSTAINABILITY  
INFRASTRUCTURE AND UTILITIES  
LAND AND PROPERTY  
MINING AND MINERAL PROCESSING  
MINERAL ESTATES  
WASTE RESOURCE MANAGEMENT

**CONTENTS**

**EXECUTIVE SUMMARY ..... 1**

    Introduction ..... 1

    Green Steel..... 1

    Location..... 1

    Geology ..... 2

    Exploration..... 3

    Mineral Resource Estimate ..... 3

    Conclusions & Recommendations ..... 5

**1 INTRODUCTION ..... 7**

    1.1 Terms of Reference ..... 7

    1.2 WAI Study Team and Site Visits ..... 7

    1.3 Professional Qualifications ..... 7

    1.4 Units and Currency ..... 8

    1.5 Auditors and Interests ..... 8

    1.6 Disclaimer ..... 8

**2 RELIANCE ON OTHER EXPERTS..... 1**

**3 PROPERTY LOCATION ..... 1**

    3.1 Licences..... 2

**4 ACCESSIBILITY, CLIMATE, AND PHYSIOGRAPHY ..... 4**

    4.1 Accessibility..... 4

    4.2 Climate ..... 4

    4.3 Vegetation..... 4

    4.4 Topography ..... 5

**5 GEOLOGICAL SETTING ..... 6**

    5.1 Regional Geology ..... 6

    5.2 Local Geology ..... 11

    5.3 Deposit Geology..... 15

    5.4 Style and Morphology of Mineralisation ..... 19

    5.5 Deposit Model..... 19

**6 EXPLORATION..... 21**

    6.1 Historical Exploration..... 21

    6.2 Akora Exploration 2014 -2019 ..... 24

    6.3 Akora Recent Exploration 2019 -2022 ..... 28

**7 DRILLING ..... 43**

    7.1 Summary ..... 43

    7.2 Types of Drilling ..... 44

    7.3 Drilling Setup and Hole Completion..... 44

    7.4 Drilling Methodology and Core Handling ..... 45

    7.5 Downhole Surveys ..... 46

    7.6 Core Orientation ..... 46

    7.7 Core Recovery ..... 46

For personal use only

7.8	Core logging .....	49
7.9	Core Photography .....	50
7.10	Sampling Methodology .....	51
7.11	Density Measurements .....	52
7.12	Drillhole Orientation Relative to Mineralisation.....	54
7.13	Summary .....	54
<b>8</b>	<b>SAMPLE PREPARATION, ANALYSIS AND SECURITY.....</b>	<b>56</b>
8.1	Laboratories Used .....	56
8.2	Sample Preparation and Splitting .....	56
8.3	Assaying and Sample Analysis Methodology.....	56
8.4	Quality Control.....	57
8.5	Chain of Custody and Sample Security .....	58
8.6	Summary .....	58
<b>9</b>	<b>DATA VERIFICATION and Quality Control Procedures .....</b>	<b>60</b>
9.1	Introduction .....	60
9.2	Database Verification.....	60
9.3	Collar Survey Verification.....	60
9.4	Down-Hole Survey Verification .....	61
9.5	Topographic Survey Verification .....	61
9.6	Density Measurement Verification.....	62
9.7	Quality Control Procedures.....	62
9.8	Twin Holes.....	79
9.9	Summary .....	79
<b>10</b>	<b>MINERAL PROCESSING AND METALLURGICAL TESTWORK.....</b>	<b>81</b>
10.1	Introduction .....	81
10.2	Metallurgical Testwork .....	81
10.3	Recovery Methods .....	84
<b>11</b>	<b>MINERAL RESOURCE ESTIMATE .....</b>	<b>88</b>
11.1	General Methodology .....	88
11.2	Data Transformations and Software.....	88
11.3	Sample Data Processing and Interpretation .....	89
11.4	Exploratory Data Analysis .....	100
11.5	Boundary/Contact Analysis.....	101
11.6	Variography.....	104
11.7	Block Modelling.....	106
11.8	Density .....	106
11.9	Grade Estimation .....	109
11.10	Mineral Resource Classification .....	114
11.11	Cut-Off Grades for Reporting Resources .....	117
11.12	Mineral Resource Statement .....	117
<b>12</b>	<b>CONCLUSIONS AND RECOMMENDATIONS .....</b>	<b>119</b>
<b>13</b>	<b>REFERENCES .....</b>	<b>122</b>

**TABLES**

For personal use only

Table 1.1: H&S Combined Mineral Resource for the Three Projects of the Bekisopa Iron Project.....	7
Table 3.1: Licence Details (Bekisopa Project) .....	2
Table 3.2: Coordinates of Licence PR 10430.....	3
Table 3.3: Coordinates of Licence PRE 3757 .....	3
Table 6.1: Summary of Holes Drilled 2020.....	28
Table 6.2: Bekisopa 2021 Drilling Campaign Details Drill Hole Locations.....	34
Table 6.3: Summary of Holes Drilled 2021.....	36
Table 6.4: Summary of Holes Drilled 2022.....	41
Table 7.1: Composition of Exploration Database .....	44
Table 9.1: WAI Global Check Comparison of Collar Locations.....	61
Table 9.2: Summary of Quality Control Samples by Exploration Programme .....	62
Table 9.3: Failure Criteria for QC Samples and Appropriate Action .....	63
Table 9.4: Re-assay of Failed CRM Sample .....	63
Table 9.5: CRM Target Grades .....	65
Table 9.6: CRM Performance 2020 (Bekisopa South).....	66
Table 9.7: Summary of Certified Reference Material Assaying in 2021 (Bekisopa South) .....	66
Table 9.8: Summary of Certified Reference Material Results in 2022 (Bekisopa South).....	68
Table 9.9: Summary of Duplicate Types .....	73
Table 9.10: HARD Acceptance Criteria.....	73
Table 9.11: Summary of Duplicate Assay Results (Bekisopa South) .....	73
Table 9.12: Akora Duplicate Performance 2020 (Bekisopa South).....	74
Table 9.13: Summary of Bekisopa Twin Drillholes.....	79
Table 10.1: Summary of Specific Testwork Results .....	82
Table 10.2: Summary of Impurity Levels from the 2mm/LIMS Option.....	83
Table 11.1: Information in Exploration Database Files.....	89
Table 11.2: Composition of Exploration Database .....	90
Table 11.3 Composite Values for DTT by DENSDOM.....	93
Table 11.4 Composite Values for Magnetic Susceptibility Values by DENSDOM .....	93
Table 11.5: Bekisopa South Mineralisation Domains .....	96
Table 11.6: Weathering and Density Domain Codes .....	98
Table 11.7: Summary Statistics for Fe (%) by MINDOM of Selected Samples .....	100
Table 11.8: Summary Statistics for Fe (%) by MINDOM of Composites .....	101
Table 11.9: Summary of Block Model Parameters .....	106
Table 11.10: Density Samples and Regression Equations by MINDOM and Weathering Horizon.....	106
Table 11.11: Estimation Parameters.....	110
Table 11.12: Comparison of Average Grades by Estimation Domain.....	113
Table 11.13: Akora MRE Constraint Optimisation Parameters .....	116
Table 11.14: Mineral Resource Estimate for the Bekisopa South Iron Project (26 <sup>th</sup> April, 2023) .....	118

FIGURES

Figure 3.1: Location of Bekisopa Project.....	1
Figure 3.2: Extents of PR 10430 and PRE 3757 Licences at Bekisopa .....	3
Figure 5.1: The Relationships between Madagascar and Surrounding Regions of Gondwana, .....	6

For personal use only

Figure 5.2: Map Showing the Geological Domains and Sub-Domains of Madagascar .....	8
Figure 5.3: Geological Map of South Central Madagascar after Tucker et al, 2011 .....	9
Figure 5.4: Total Magnetic Intensity Image of South Central Madagascar after Tucker et al, 2011 ..	10
Figure 5.5: Geological Map of the Bekisopa Area after GAF-BGR, 2008.....	12
Figure 5.6: Geological Map of the Bekisopa Area.....	14
Figure 5.7: Satellite Imagery Showing Surface Expression of Iron Mineralisation .....	15
Figure 6.1: BRGM Geological Mapping at Bekisopa.....	22
Figure 6.2: Plan View of Historic Trenches and Pits, and Recent Sampling by AKORA.....	23
Figure 6.3: Akora Rock Chip Sampling Results .....	25
Figure 6.4: Bekisopa Iron Project - Magnetic Image (Analytical Signal),.....	27
Figure 6.5: Location of 2020 Drill Holes .....	29
Figure 6.6: Interpreted Cross-Section Through BEKD01 .....	31
Figure 6.7: Bekisopa Drill Camp .....	32
Figure 6.8: Recent Drill Core from BEKD13 and BEKD14 .....	32
Figure 6.9: 2021 Bekisopa Drilling Campaign Drill Hole Location Plan .....	33
Figure 6.10: BEKD14 and BEKD13 Drillholes .....	34
Figure 6.11: Location of 2021 Drillholes, Southern Zone .....	37
Figure 6.12: Map Showing the Drillhole Locations at Bekisopa South .....	40
Figure 7.1: EP200 Drilling Rig used for the 2022 Infill Drilling .....	43
Figure 7.2: DGPS Survey of Drill Collars. ....	45
Figure 7.3: Box-and-Whisker Plot Showing Recoveries Against Logging of Weathering.....	47
Figure 7.4: Box-and-Whisker Plot Showing Recoveries For Each Drill Programme .....	48
Figure 7.5: HexBin Plot Showing Fe (%) Grades Plotted Against Recovery Values.....	48
Figure 7.6: Logging Sheet for Drill Hole BEKD132.....	50
Figure 7.7: Photograph of Dry Core From BEKD132 Before Sampling.....	51
Figure 7.8: Photograph of Wet Half Core From BEKD132 After Being Sampled. ....	51
Figure 7.9: Illustration Showing Sampling Method (Source: Vato Consulting).....	52
Figure 7.10: Density Results from Core Samples at Bekisopa South Split by Year Drilled.....	53
Figure 7.11: Scatter plot Showing Fe Grade Against Density Measurements .....	54
Figure 9.1: Performance of CRM OREAS 40 During 2021 Drilling at Bekisopa South .....	67
Figure 9.2: Performance of CRM OREAS 404 During 2021 Drilling at Bekisopa South .....	67
Figure 9.3: Performance of AKORA’s CRM OREAS 404 During 2022 Drilling at Bekisopa South .....	69
Figure 9.4: Performance of ALS CRM NCSDC18014 During 2022 Drilling at Bekisopa South.....	69
Figure 9.5: Performance of Blank Sample AMIS0681 During 2021 Drilling at Bekisopa South .....	71
Figure 9.6: Performance of Blank Sample AMIS0793 During 2022 Drilling at Bekisopa South .....	71
Figure 9.7: Performance of ALS Internal Blank Sample During 2022 Drilling at Bekisopa South .....	72
Figure 9.8: Performance of Akora Duplicate Samples during 2021 drilling at Bekisopa South.....	75
Figure 9.9: Performance of Akora Duplicate Samples during 2022 Drilling at Bekisopa South .....	76
Figure 9.10: Performance of ALS Duplicate Samples during 2022 Drilling at Bekisopa South .....	77
Figure 9.11: Comparison of Downhole Fe Grades for BEKD043 and BEKD043A (left) .....	79
Figure 10.1: Block Flow Diagram of the Typical Circuit for DSO Material .....	85
Figure 10.2: Block Flow Diagram of the Typical Circuit for 2mm Crush and Dry LIMS Option .....	86
Figure 10.3: Block Flow Diagram of the Typical Circuit for Fine Grind and WHIMS Option .....	87
Figure 11.1: Isometric View of Drillholes Coloured by Drilling Year .....	91

Figure 11.2: Sample Distribution (Fe) by Drill Programme at Bekisopa South ..... 91  
 Figure 11.3: Log Histograms Comparing Statistics Pre-Composited Magnetic Susceptibility ..... 93  
 Figure 11.4: Log Histogram and Log Probability Plot for Bekisopa South Fe Assays ..... 94  
 Figure 11.5: Contiguous Length Analysis of the DSO Fe Grades ..... 95  
 Figure 11.6: Bekisopa South Mineralisation Domains ..... 96  
 Figure 11.7: Previous H&S Block Model Overlain by Updated WAI Wireframe Interpretation ..... 97  
 Figure 11.8: Updated WAI Block Model Overlain by Previous H&S Wireframe Interpretation ..... 98  
 Figure 11.9: Section Showing Weathering Surfaces at Bekisopa South ..... 99  
 Figure 11.10: Section Showing DENS DOM Code in Block Model, Sub-blocking at MINDOM and Oxidation Boundaries and Drillholes Showing Fe (%) ..... 99  
 Figure 11.11: Histogram of Sample Lengths ..... 101  
 Figure 11.12: Contact Plot for Bekisopa South - West DSO. Red = Inside DSO wireframe ..... 102  
 Figure 11.13: Contact Plot for Bekisopa South - East DSO. Red = Inside DSO wireframe ..... 103  
 Figure 11.14: Contact Plot for Bekisopa South - East Green Steel ..... 103  
 Figure 11.15: Experimental Variograms Fe (%) for MINDOM 1 ..... 104  
 Figure 11.16: Experimental Variograms Fe (%) for MINDOM 2 ..... 105  
 Figure 11.17: Experimental Variograms Fe (%) for MINDOM 3 ..... 105  
 Figure 11.18: Density Regression Analysis for MINDOM 1 by OXIDE Domain ..... 107  
 Figure 11.19: Density Regression Analysis for MINDOM 2 by OXIDE Domain ..... 108  
 Figure 11.20: Density Regression Analysis for MINDOM 3 by OXIDE Domain ..... 108  
 Figure 11.21: Density Regression Analysis for MINDOMs 4, 5 and 7 by OXIDE Domain ..... 109  
 Figure 11.22: Section Showing Model vs Downhole Composite Grades in MINDOM1 ..... 111  
 Figure 11.23: Section Showing Model vs Downhole Composite Grades in MINDOM 2 & 3 ..... 111  
 Figure 11.24: Example Swath Plots for MINDOM 1, 2 and 3 (Fe %) ..... 112  
 Figure 11.25: Bekisopa South Mineral Resource Classification (Blue – Indicated; Red – Inferred).... 116

**PHOTOGRAPHS**

Photo 5.1: Outcrop of Magnetite-Hematite (showing remnant structure) ..... 16  
 Photo 5.2: Magnetite Particles on Hand Magnet from Red Soil ..... 16  
 Photo 5.3: Creek Exposing Red, Iron-Rich Regolith at Bekisopa South ..... 17  
 Photo 5.4: Outcrop of Massive Magnetite+/-Hematite ..... 18  
 Photo 5.5: Outcrop of Massive Magnetite with Magnetite Rich Layer, after Akora Resources ..... 18  
 Photo 6.1: Drilling of holes BEKD01: BEKD09: BEKD10: BEKD11 ..... 30  
 Photo 6.2: High-Grade Iron Mineralisation BEKD029 ..... 39

**APPENDICES**

Appendix 1 – JORC Table 1  
 Appendix 2 – Certified Reference Material Analysis  
 Appendix 3 – Blank Material Analysis  
 Appendix 4 – Pulp Duplicate Analysis  
 Appendix 5 – Variography

## EXECUTIVE SUMMARY

### Introduction

Wardell Armstrong International (“WAI”) was commissioned by Akora Resources Ltd (“Akora”) to produce an updated Mineral Resource Estimate (“MRE”) for the Bekisopa South Iron Project (“the Project”) in south central Madagascar. The Project is part of the overall Bekisopa Iron Project which extends for approximately 7km and includes the Northern, Central and Southern areas. The Southern area is currently the most advanced in terms of exploration and is the subject of this MRE.

The Bekisopa South Iron Project is a greenfield project and Akora is intending to develop it as an open pit operation with a focus on rapidly bringing into production near-surface, high-grade oxidised material as Direct Shipment Ore (“DSO”) which is found in two zones (Eastern and Western zones). Underlying the DSO is a larger, deeper zone of transitional and sulphide mineralisation termed the “Green Steel” zone which is considered amenable for use in the production of green steel.

### Green Steel

The definition of “Green Steel” as used by WAI is “the production of steel without the use of and coking coal and powered using natural gas and potentially hydrogen and other renewables. For steel to be produced in this manner, that is, no carbon from coking coal as the main reductant, the grade of the iron ore feed must be both very high in iron content, greater than 67% Fe, and very importantly low in impurities of Silica and Alumina”.

Iron concentrates from Bekisopa are at 68.7% Fe and with combined silica and alumina impurity levels averaging less than 2%, this is likely to be very suitable as Green Steel iron ore feed material.

### Location

The Project is situated in the southern central region of Madagascar, around 350km southwest of the capital city, Antananarivo. The Project site is located approximately 7.5km to the northeast of the town of Bekisopa, which is located in the Haute Matsiatra region and falls under the jurisdiction of the municipality of Tanamarina.

The Project site is remote with no significant infrastructure and is accessed via a dirt track from the main RN7 highway located some 75km to the south. A new access road connecting the site to the highway will be required to develop the Project. The west coast of Madagascar is approximately 220km from the site, from which DSO or concentrate could potentially be shipped.

The topography of the Project comprises a low hill of iron mineralisation which strikes approximately north to south, bounded by low valleys and larger ridges on either side. No significant settlements or agricultural land are found within the Project site and there is sufficient open space for further project development.

## Licence

The licenses that comprise the overall Bekisopa Project (inclusive of Northern, Central and Southern areas) consist of a granted research permit (PR 10430) and a granted small scale mining permit (PRE 3757). Of these, Bekisopa South falls within the PR 10430 licence.

The exploration permit (or “PR” permit) gives the holder the exclusive right to carry out prospecting and research activities within a defined area. The PR permit allows the holder, the right to apply for an exploitation (mining) permit or “PRE” permit covering all or part of the area covered by the PR permit. An environmental commitment plan is an additional requirement condition of the exploration permit.

Applications to renew the licenses were made by Akora in May 2022 in a timely manner, however, feedback from the authorities is still awaited. It not uncommon in these instances, for renewal applications (even when made timeously and in accordance with the prevailing mining law) to extend beyond anticipated timeframes. The requisite environmental commitment plan for exploration was submitted by Akora to the Direction Générale des Mines on 30<sup>th</sup> March, 2021.

## Geology

The Project is located within the Anosyen Domain and Ikalamavony sub-domain of Madagascar. The local geology consists of a calc-silicate unit within schists and gneisses. The calc-silicate unit appears to be a favourable host for deposition of iron mineralisation from metasomatic fluids derived from either magmatic or metamorphic processes. Broad layers of massive magnetite – hematite are traceable over the entire 7km extent of the overall Bekisopa tenements. Mineralisation is interpreted as a series of parallel layers of predominantly massive magnetite-hematite with thicknesses of a few metres up to 20-50m, within the magnetite bearing host rocks. Disseminated mineralisation is also present and includes both coarse and disseminated types.

The mineralisation has the form of a tabular zone or zones and trends from steeply westerly dipping in the north to moderately westerly dipping in the centre and moderately to flat dipping in the south. Faulting is not apparent on a large scale but may be present on a smaller scale that has not been identified with the current drill spacing. East-west faults, represented by small valleys separating the three zones, are hypothesised and require further investigation.

Oxidation is variable, but generally complete oxidation is between 5 and 20m below surface. There has been some iron enrichment in the oxidised zone due to removal of host rock material via weathering, resulting in the presence of DSO (>58% Fe) in the upper, completely oxidised zone and in surficial scree derived from this material. Transitional and primary mineralisation is found below the oxidised zone. Iron mineralisation occurs dominantly as magnetite although some hematite is noted, in particular within the near surface environments.

## Exploration

Prior to Akora, three historical exploration programmes have taken place in the overall Bekisopa tenements:

- French Geological Society (“BRGM”) in 1959-1962;
- United Nations Development Program (“UNDP”) in 1976-1978; and
- Cline Mining Corp. in 2007-2008.

BRGM completed geological mapping, geophysical surveying, trenching (4,000m), pitting (564 pits for 1,862m), drilling (22 holes aggregating 572m), petrology and geochemical analysis (2,581 samples) and identified high grade iron occurrences. UNDP, built on the BRGM work with further pitting, drilling and mapping. Additional geophysical work was carried out by Cline Mining, initially concentrated on geophysics with the World Bank funded airborne magnetic and radiometric survey, carried out by FUGRO, as their starting point. Further ground geophysical surveys including gravity, magnetics and ground penetrating radar, provided further data.

Akora has been exploring at Bekisopa since 2014, completing a comprehensive ground magnetic survey in 2019 by Planetary Geophysics, Australia, which revealed a relatively consistent magnetic body extending over approximately 7km strike length.

Following the positive geophysical survey, Akora completed three phases of drilling, exclusively diamond core. Holes were generally drilled toward the east in 2020 and 2021, with vertical shallow (<30m) drillholes during 2022. Drilling contractor Croft Drilling Services (“CDS”) completed the diamond drilling programmes in 2020-2022 with a man portable EP200 drilling rig for drill holes less than 100m in length, and a MP500 drilling rig for drill holes greater than 100m in length. Drilling in 2022 consisted of infill drilling focusing on Bekisopa South, the subject of this MRE.

## Mineral Resource Estimate

Mineral Resource estimation was undertaken by WAI using drillhole information from the 2020, 2021 and 2022 drilling programmes completed by Akora. A 3D block modelling approach using Datamine Studio RM and Snowden Supervisor software was used. Exploration data were imported and verified before appropriate mineralisation and weathering envelopes were defined by 3D wireframes, based on the current understanding of the deposit.

Mineralisation domains were based on nominal cut-off grades of 58% Fe for the DSO and 25% Fe for the Green Steel zone. Weathering surfaces were constructed for the base of complete weathering and base of moderate weathering using geological logging data.

The wireframe envelopes were used as the basis for a volumetric block model based on a parent cell size of 20m x 20m x 5m, but with sub-celling allowed to 2.5m x 2.5m x 1m to give a best fit against

wireframe boundaries and limits. The block model was coded with appropriate keyfields for mineralised domain and weathering horizons.

Grades for Fe, SiO<sub>2</sub>, Al<sub>2</sub>O<sub>3</sub>, Mn, P, and TiO<sub>2</sub> were estimated into the block model representing each mineralised domain. Grade estimation was carried out using inverse distance weighting estimation. Estimated grades were validated globally, locally, and visually. Density was estimated into the block model from drillhole data using regressed density values from Fe grades.

The MRE for the Bekisopa South Iron Project is classified in accordance with the JORC Code (2012). Indicated Mineral Resources were assigned to areas of the DSO zones covered by exploration drillholes on a grid of 50m x 50m. Inferred Mineral Resources were classified for all remaining areas outside of the 50m x 50m spaced grid or where geological complexity is observed. For the Green Steel zone, the moderately weathered and unweathered portions (including areas covered by deeper drillholes at a spacing of 100m x 150m) were classified as Inferred Mineral Resources. The highly weathered portion of the Green Steel zone was excluded due to higher levels of impurities associated with this zone. The MRE was limited by an open pit optimisation using technical and economic parameters.

The stated Mineral Resources are not materially affected by any known environmental, permitting, legal, title, taxation, socio-economic, marketing, political or other relevant issues, to the best knowledge of the author. There are no known mining, metallurgical, infrastructure, or other factors that materially affect this Mineral Resource Estimate, at this time.

A summary of the Mineral Resource statement is shown in the table below. The effective date of the Mineral Resource Estimate is 26<sup>th</sup> April, 2023.

Mineral Resource Estimate for the Bekisopa South Iron Project (26 <sup>th</sup> April, 2023)								
Classification	Tonnes (Mt)	Density (t/m <sup>3</sup> )	Fe (%)	Al <sub>2</sub> O <sub>3</sub> (%)	Mn (%)	P (%)	SiO <sub>2</sub> (%)	TiO <sub>2</sub> (%)
<b>Western DSO Zone</b>								
Indicated	1.63	3.68	60.15	2.65	0.115	0.107	7.01	0.107
Inferred	0.33	3.74	58.83	2.54	0.115	0.131	6.37	0.120
<b>Eastern DSO Zone</b>								
Indicated	2.80	3.21	61.28	3.38	0.088	0.104	4.80	0.143
Inferred	0.79	2.92	58.13	4.23	0.066	0.107	6.04	0.169
<b>Total DSO</b>								
Indicated	4.42	3.37	60.86	3.11	0.098	0.105	5.61	0.129
Inferred	1.12	3.13	58.34	3.73	0.081	0.114	6.14	0.154
<b>Green Steel Zone</b>								
Inferred	34.00	4.02	45.26	2.14	0.090	0.237	13.82	0.083

**Notes:**

1. Mineral Resources for the DSO zones are not reported using a cut-off grade as no cut-off grade is required for these zones. Mineral Resources for the Green Steel zone are reported using a cut-off grade of 36% Fe.
2. Mineral resources are limited to an optimised open pit shell based on appropriate economic and mining parameters.
3. Mineral Resources are not Ore Reserves until they have demonstrated economic viability based on a Pre-Feasibility Study or Feasibility Study.
4. Mineral Resources are reported inclusive of any Ore Reserves.

5. Mineral Resources for the Bekisopa South Iron Project have been classified in accordance with the guidelines of the JORC Code (2012) by Richard Ellis, an independent Competent Person as defined by JORC.
6. The Mineral Resource Estimate has not been affected by any known environmental, permitting, legal, title, taxation, socio-political, marketing or any other relevant issues.
7. Contained metal refers to estimated contained metal in the ground not adjusted for metallurgical recovery.
8. All figures are rounded to reflect the relative accuracy of the estimate, and apparent errors may occur due to rounding.

## Conclusions & Recommendations

Given the availability of DSO material, supplemented by large tonnages of transitional and primary mineralisation directly underneath that is amenable for use in the production of “green steel”, the Bekisopa South deposit warrants further exploration and WAI makes the following recommendations:

### *Exploration Procedures*

- Validate density measurements with laboratory testwork to confirm accuracy of field measurements. Additional density testwork should be undertaken to further confirm the densities for DSO zones.
- A geological and structural model for the deposit should be developed to increase the understanding of areas of the distribution of DTT recoveries within the deposit.
- WAI recommends that DTT testwork is tailored to specific mineralisation/geological domains. This will allow better understanding of the relationship between magnetic susceptibility and DTT recoveries, and any relationship between DTT and mineralogy/lithology.

### *QA/QC Procedures and Sample Analysis*

- Field duplicates should be incorporated to track the precision of sampling throughout the entire drilling process.
- Samples with Sulphur values above the maximum reporting limit (~5%) should be re-assayed by the laboratory, typically using a different method with greater reporting limits; this would allow for estimation of Sulphur in the block model.
- Use of an umpire lab to improve confidence in assay results (for example, some ALS internal standards reported anomalous values and should be further investigated).
- Additional twinning of drillholes should be undertaken to further assess the short-range grade variability through the deposit.

### *Exploration Database Management*

- A specialist exploration database package such as Fusion may be beneficial in organising exploration data in a more robust manner. This type of software generally has in-built data validation tools, authorisation protocol and provision made for the inclusion of QA/QC samples. As the project database expands, this will become increasingly important.

### Exploration Programme

- Consider alternative percussion drilling methods to lower drilling costs, particularly for the near-surface DSO material (WAI understands that alternative drilling contractors are difficult to find in Madagascar).
- Orientated drill core should be incorporated into the next phase of deeper drilling at Bekisopa to gain better understanding of the deposit geology and structure. Attempting orientated core on shallow, regolith material is unlikely to provide useful information.
- Re-logging of core to enhance understanding and classification of lithologies. For example, some core may have been incorrectly logged as gneiss yet shows characteristics of amphibolite (i.e. no strong foliation/gneissose banding).
- Cleaning and re-sampling of existing UNDP and BRGM trenches. These offer an excellent source of information at a much lower cost than drilling and could potentially be incorporated into an MRE if sampling is performed to a high standard with QA/QC implemented. The near-surface DSO is the main focus and therefore trenching will enhance the confidence in the early stages of the mine plan.
- Additional short, vertical drillholes have already been planned for 2023 to further test the DSO potential of Bekisopa North and Central. WAI would recommend including deeper holes within this programme to continue to test the depth potential of the deposit. WAI understands that some additional short drillholes will also be completed at the DSO zones at Bekisopa South in 2023 as part of this programme.
- WAI recommends that additional drilling should be completed at Bekisopa South, specifically:
  - Along the north and south strike extents of both the Western and Eastern DSO zones;
  - To the west of the Western zone to test high grade DSO intersected in the drillholes from BEKD146 through to BEKD134 further north;
  - To the east of the Eastern Zone to test high grade DSO intersected in BEKD081 & BEKD091; and
  - Infill drilling at depth to:
    - Define the Green Steel resource potential;
    - Improve understanding of the geology and structure of the orebody and distribution of mineralisation types (massive, coarse disseminated and fine disseminated)
    - Better determine the relationship between oxidation and grade; and
    - Upgrade Inferred Mineral Resources.

## 1 INTRODUCTION

### 1.1 Terms of Reference

Wardell Armstrong International was commissioned by Akora Resources Ltd to provide consultancy services with respect to a Mineral Resource Estimate for the Southern Zone of the Bekisopa Iron Project, Madagascar.

In September 2022, H&S Consulting (“H&S”) completed a maiden MRE for the overall Bekisopa Project inclusive of the Southern, Central and Northern areas (Table 1.1).

<i>Inferred</i>	<b>Tonnes (Mt)</b>	<b>DTT (%)</b>	<b>Fe Head Grade (%)</b>	<b>Concentrate Grade (% Fe)</b>	<b>Density (t/m<sup>3</sup>)</b>	<b>DTT (Mt)</b>
<b>Southern</b>	110.2	37.8	32	67.6	3.22	42
<b>Central</b>	41.2	36.3	30	67.0	3.22	15
<b>Northern</b>	43.3	43.3	33.3	68.2	3.22	19
<b>Total</b>	<b>194.7</b>	<b>38.7</b>	<b>32</b>	<b>67.6</b>	<b>3.22</b>	<b>75.4</b>

WAI was commissioned to update the MRE for the Southern Zone of the Bekisopa Project where an additional 86 Diamond drillholes were completed by Akora from September to October 2022. The rationale for the updated MRE on the Southern Zone is to include the information from the new drilling.

WAI has carried out previous technical assignments on this deposit which include:

- 1) CPR of the Bekisopa, Tratamarina, and Ambodilafa Iron Ore Projects, Madagascar (November 2020); and
- 2) Scoping Study Report for Akora Resources on the Bekisopa Iron Ore Project, Madagascar (October 2022)

### 1.2 WAI Study Team and Site Visits

Mr Robin Kelly (BSc, MSc, MCSM, MIMMM), WAI Principal Geologist, visited the Bekisopa Project between the 4<sup>th</sup> to 11<sup>th</sup> May 2023, to observe the site geology and diamond drill core. Mr Richard Ellis (BSc, MSc, MCSM, FGS, CGeol, EurGeol) was the Competent Person for the Mineral Resource Estimate.

### 1.3 Professional Qualifications

WAI is part of Wardell Armstrong LLP, an independent consultancy that has provided the mineral industry with specialised geological, mining, and processing expertise since 1837. Our experience is worldwide and has included all commodities.

WAI provides a wide range of services for minerals-related projects. These range from preliminary exploration planning, through Mineral Resource and Ore Reserves estimation, mine design and financial appraisal, to bankable final feasibility study.

WAI has professionally qualified and experienced specialists in mining geology, mining engineering, processing, rock mechanics and hydrogeology, mineral surveying, computing, financial evaluation, environmental and social assessments and mineral economics.

#### **1.4 Units and Currency**

All units of measurement used in this report are metric unless otherwise stated. Tonnages are reported as metric tonnes (“t”), base metal values in percentage (“%”), precious metal values in grams per tonne (“g/t”) or troy ounces (“t.oz”). Unless otherwise stated, all references to currency or “\$” are to United States Dollars (US\$), with US\$M being 1 million United States Dollars.

#### **1.5 Auditors and Interests**

WAI, its directors, employees and associates neither has nor holds:

- Any rights to subscribe for shares in Akora either now or in the future;
- Any vested interests in any concessions held by Akora;
- Any rights to subscribe to any interests in any of the concessions held by Akora, either now or in the future;
- Any vested interests in either any concessions held by Akora or any adjacent concessions; and
- Any right to subscribe to any interests or concessions adjacent to those held by Akora, either now or in the future.

WAI’s only financial interest is the right to charge professional fees at normal commercial rates, plus normal overhead costs, for work carried out in connection with the investigations reported here. Payment of professional fees is not dependent either on project success or project financing.

#### **1.6 Disclaimer**

The observations, comments and results of this audit presented in this report represent the opinion of WAI consistent with the data in this report and are based on the work as stated in the report. While WAI is confident that the opinions presented in this report are reasonable, a substantial amount of data has been accepted in good faith. Although WAI has visited the asset described in this report, WAI did not conduct any verification or quality control sampling. WAI cannot therefore accept any liability, either direct or consequential, for the validity of such information accepted in good faith.

## 2 RELIANCE ON OTHER EXPERTS

This Report has been prepared by WAI on behalf of Akora. The information, data, conclusions, opinions, and estimates contained herein are based on:

- Information available to WAI at the time of preparing this Report, including previous technical reports prepared on Bekisopa;
- Assumptions, conditions, and qualifications as set forth in this technical report; and
- Data, reports, and other information supplied by Akora and other third-party sources.

The Competent Persons have not carried out any independent exploration work, drilled any holes or carried out any sampling and assaying on the Project.

The authors have relied on information provided by Akora as of April 26, 2023, regarding the legal status of the rights pertaining to the Bekisopa Project and have not independently verified the legality of surface land ownership, mineral tenure, legal status or ownership of the properties or any agreements that pertain to the licence areas.

The authors did not verify the legality of any underlying agreement(s) that may exist concerning the permits or other agreement(s) between third parties but have relied on information provided by Akora as of April 26, 2023, for land title issues.

### 3 PROPERTY LOCATION

The Bekisopa Iron Project is situated in the southern central region of Madagascar, around 350km southwest of the capital city, Antananarivo. The Project site is located approximately 7.5km northeast of the town of Bekisopa in the region of Haute Matsiatra in central Madagascar and is part of the municipality of Tanamarina, see Figure 3.1. The main village of Tanamarina is approximately 26km away from the main Bekisopa tenements, and the journey by road takes approximately one hour. The Project site is located approximately 220km from the west coast, from which DSO or concentrate could potentially be shipped.

For personal use only



**Figure 3.1: Location of Bekisopa Project**

([https://www.nationsonline.org/oneworld/map/madagascar\\_map.htm](https://www.nationsonline.org/oneworld/map/madagascar_map.htm))

The villages are remote and some 75km from the road network. Although there are similar settlements within the surrounding area, there is currently no infrastructure that may be utilised for any of the proposed project development.

It is considered doubtful that the local population within the town of Bekisopa and surrounding areas, will have the desired skill sets to satisfy the labour resource requirement for the mine construction and future operations.

While there may be availability of manual labour for highway construction purposes, WAI considers the greater proportion of the workforce will have to be attracted into the area. Similarly, it is anticipated that the mine site shall need to provide for all accommodation and welfare facilities due to the none-availability of such within the general vicinity.

### 3.1 Licences

The licenses that comprise the overall Bekisopa Project (inclusive of Northern, Central and Southern areas) consist of a granted research permit (PR 10430) and a granted small scale mining permit (PRE 3757). Of these, Bekisopa South falls within the PR 10430 licence.

The exploration permit or “PR” permit gives the holder the exclusive right to carry out prospecting and research activities within a defined area. The PR permit allows the holder, the right to apply for an exploitation (mining) permit or “PRE” permit covering all or part of the area covered by the PR permit. An environmental commitment plan is an additional requirement condition of the exploration permit. A summary of the licence details is shown in Table 3.1.

Table 3.1: Licence Details (Bekisopa Project)						
Tenement Holders	Permit ID	Permit Type	Number of Blocks	Granting Date	Actual Status	Date of last Payment
IOCM	10430	PR	64	04/03/2004	All fees paid August 2021: Under renewal process	May 2022
RAZAFIN-DRAVOLA	3757	PRE	16	26/03/2001	All fees paid August 2021: Transfer from IOCM Gerant to AKO	May 2022

Applications to renew the licenses were made by Akora in May 2022 in a timely manner, however, feedback from the authorities is still awaited. It not uncommon in these instances, for renewal applications (even when made timeously and in accordance with the prevailing mining law) to extend beyond anticipated timeframes. The requisite environmental commitment plan for exploration was submitted by Akora to the Direction Générale des Mines on 30<sup>th</sup>March, 2021.

The licence coordinates are shown in **Table 3.2** and **Table 3.3** and the extents of the licences are shown in Figure 3.2.

For personal use only

<b>Table 3.2: Coordinates of Licence PR 10430</b>			
Corner Coordinates of Licence PR 10430			
LABORDE		UTM WGS84	
Longitude	Latitude	Longitude	Latitude
335,000	502,500	583,778.40	7,612,479.28
340,000	502,500	588,779.10	7,612,434.96
340,000	497,500	588,734.77	7,607,434.26
335,000	497,500	583,734.08	7,607,478.61

<b>Table 3.3: Coordinates of Licence PRE 3757</b>			
Corner Coordinates of Licence PR 3757			
LABORDE		UTM WGS84	
Longitude	Latitude	Longitude	Latitude
335,000	505,000	583,800.56	7,614,979.61
337,500	505,000	586,300.90	7,614,957.47
337,500	502,500	586,278.75	7,612,457.13
335,000	502,500	583,778.40	7,612,479.28



**Figure 3.2: Extents of PR 10430 and PRE 3757 Licences at Bekisopa**

## 4 ACCESSIBILITY, CLIMATE, AND PHYSIOGRAPHY

### 4.1 Accessibility

A new access road for the Project will be required to connect the site to the main highway RN7 which is approximately 75km south from the mine site.

While the routing has yet to be finalised, at least one bridge will need to be constructed. There are no identifiable townships or major infrastructure facilities that need to be avoided, thereby mitigating any associated risk elements and any potential social and environmental issues.

The access road will be designed to include a minimum of 7.5m width and lateral drainage channels of 0.7m wide. The road is planned to be sealed and paved with asphalt of 7cm thickness on a suitably constructed 35cm thick artificial base and is planned to comply with the American Society for Testing and Materials (ASTM) standard for construction, or to a suitably comparable EN Standards.

### 4.2 Climate

The combination of south-easterly trade winds and north-westerly monsoons, produces a hot rainy season (November–April), with frequently destructive cyclones, mainly in the north and eastern areas which weaken considerably as they move inland, and a relatively cooler dry season (May–October).

Rain clouds originating over the Indian Ocean discharge much of their moisture over the island's eastern coast; the heavy precipitation supports the area's rainforest ecosystem.

The central highlands are both drier and cooler while the west is drier still, and a semi-arid climate prevails in the southwest and southern interior of the island where the Bekisopa project is located.

### 4.3 Vegetation

The climate in Madagascar is dominated by the south-eastern trade winds that originate in the Indian Ocean anticyclone, a centre of high atmospheric pressure that seasonally changes its position over the ocean. Madagascar has two seasons: a hot, rainy season from November to April and a cooler, dry season from May to October.

July is the coolest month, with island temperatures ranging between 10°C to mid-20s°C, and December is the hottest month, with temperatures between mid-23°C to high 27°C. Temperatures generally decrease with elevation, being highest on the northwest coast, and lowest on the plateau. Tropical cyclones occur especially from December to March, approaching the eastern coast, bringing torrential rains and destructive floods.

Madagascar was once covered with evergreen and deciduous forest, but little of this now remains except on the eastern escarpment and in a few scattered places in the west. The forest has been cut

to obtain fuel, building materials and to export valuable timber (ebony, rosewood, and sandalwood), the barren land is used for rice fields and cattle (Zebu) grazing. The stripping of the plateau has caused serious erosion.

About seven-eighths of the island is now covered with prairie grasses and bamboo with screw pines, palms, and reeds growing in coastal areas. The southern part of the island is arid desert where thorn trees, giant cacti, dwarf baobab trees, pachypodium succulents, xerophytes and drought-resistant plants grow.

#### 4.4 Topography

The District of Ikalamavony has some rugged relief with average altitudes of 850m, formed by hills and peneplains. The eastern chain of Maroneviky stands for a few tens of kilometers comprising an almost continuous cliff, whose height differences compared to the lower area of the Valley of Bekisopa and the plain of Tsitondroina reach 150 to 500m.

The western range is almost as high and has a similar composition, but is 4 to 6km further west, it has acute ridges rising from 200m to 250m above the surrounding areas. The intermediate zone, slightly depressed (about 850m above sea level) forms gently sloping plateaus towards the District of Ikalamavony which has little rugged relief and has an average altitude of 850m, formed by hills and peneplain. The eastern chain of Maroneviky is a few tens of kilometers (an almost continuous cliff compared to the lower area of the Valley of Bekisopa and the plain of Tsitondroina)

The intermediate zone, slightly depressed (about 850m above sea level) forms gently sloping plateaus towards the North and South, which are separated by the manamisoa transverse link (1,092m above sea level) where the two chains seem to meet (north of the project area). It is in this part that the project area is located, 7.5km northwest of the village of Bekisopa.

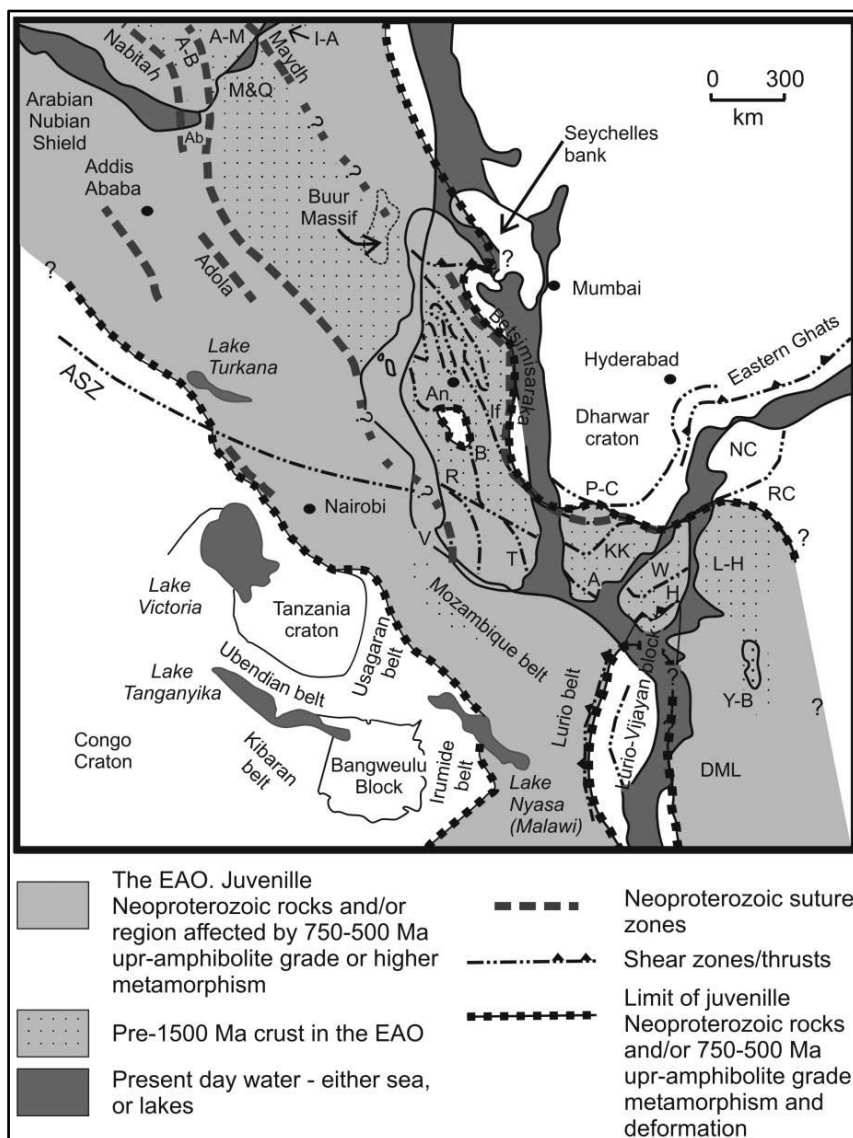
## 5 GEOLOGICAL SETTING

### 5.1 Regional Geology

The island of Madagascar lies within the East African Orogen (“EAO”), a relatively poorly understood formation, consisting of deformed and metamorphosed basement gneiss. These metamorphic units were formed during the formation of the supercontinent Gondwana in the late Neoproterozoic to Cambrian (Figure 5.1). Madagascar forms part of the EAO which incorporates the Middle East, East Africa, southern India, Sri Lanka, and eastern Antarctica (Stern, 1994).

Southern Madagascar is separated from Central and Northern Madagascar by the Ranotsara shear zone (Windley et al. 1994). Southern Madagascar is classified as Gondwana, with the Central and Northern regions as part of the EAO.

For personal use only



**Figure 5.1: The Relationships between Madagascar and Surrounding Regions of Gondwana, after Collins & Windley, 2015. “An” denotes Antananarivo**

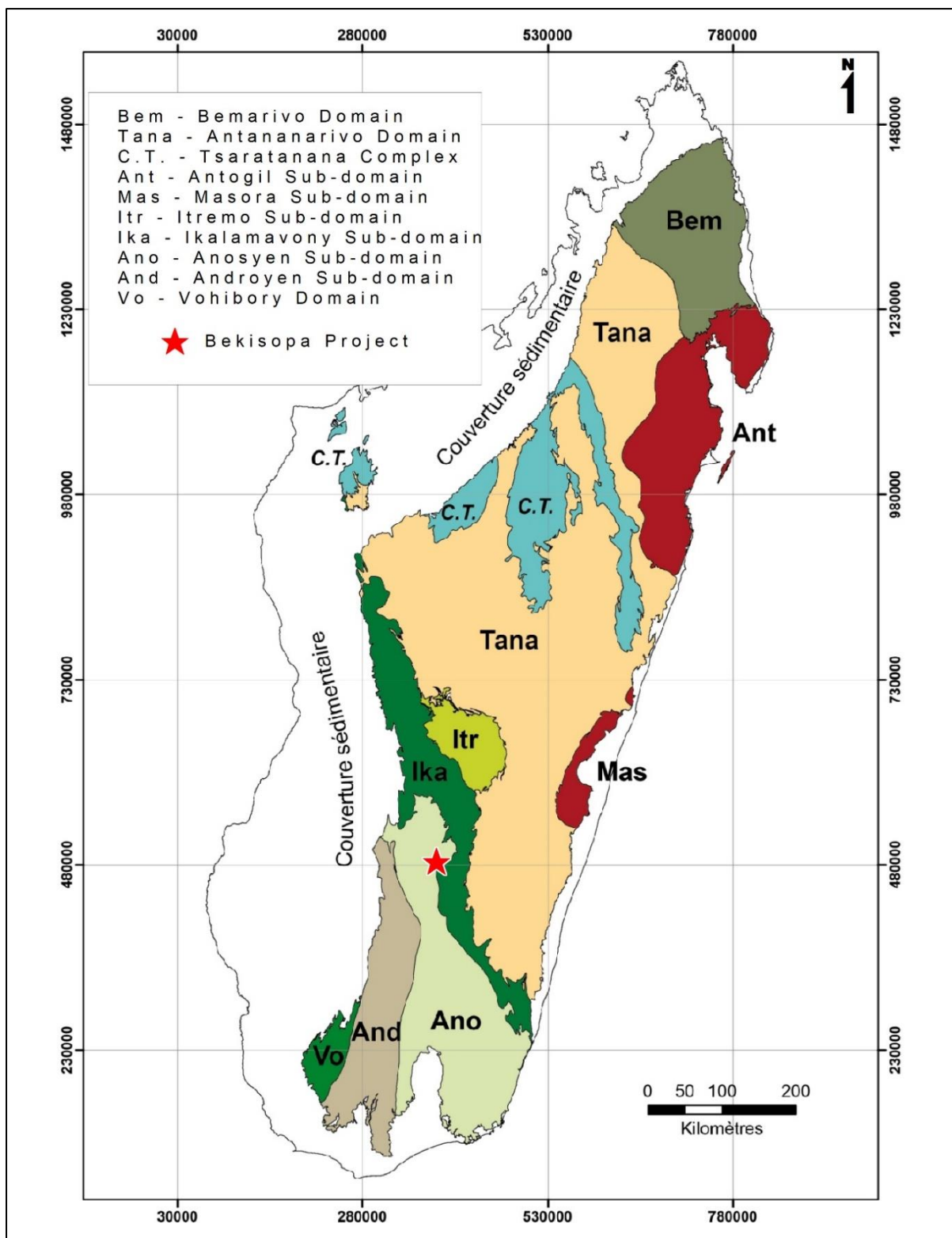
The Precambrian shield of south-central Madagascar, excluding the Vohibory region, consists of three geological domains, from north to south: Antananarivo, Itremo-Ikalamavony and Androyen-Anosyen (Figure 5.2, Figure 5.3 and Figure 5.4).

The Neoproterozoic rocks of the Antananarivo Domain consist of granitic gneiss, with older remnants of paragneiss and four distinctive belts of mafic gneiss and schist (Tsaratanana Complex). In central Madagascar the Antananarivo Domain is overlain by Proterozoic metaclastic rocks (Ampasary, Anbatolampy and Manampotsy Groups) all with an enigmatic signature of Paleoproterozoic (2.2-1.8Ga) detritus. All of the Proterozoic Groups, and their Archean basement, are intruded by early Neoproterozoic (820-740Ma) and late Neoproterozoic (560-530Ma) batholiths, stocks and small massifs, e.g. the Imorona-Itsindro, Maevarano-Ambalavao, Ankiliabo and the Dabolava Suites (Tucker et al, 2011).

The Itremo-Ikalamavony Domain is a 100-200km wide northwest-southeast trending orogenic belt that extends across southwest Madagascar. Two Sub-domains are recognised – the Itremo and Ikalamavony Sub-domains – each of them defined by similar but slightly different types of intrusive igneous and stratified metamorphic rocks. The Itremo Sub-domain, in the east, is characterised by a group of stratified rocks composed of very pure, highly sorted quartzite, mature metashale and dolomitic marble (Itremo Group) and also contains Neoproterozoic migmatite gneiss. The much larger Ikalamavony Sub-domain, in the west, is characterised by thick quartzite formations near its base, but its upper formations consist of feldspathic leucogneiss, amphibolite, and rare bands of thin calcite marble and calc-silicate gneiss. Like the Itremo Sub-domain, the Ikalamavony Sub-domain includes Neoproterozoic migmatite gneiss (Tucker et al, 2011).

The Precambrian stratified rocks of south Madagascar were first classified by Besairie (1971) into three systems, from west to east, the Vohibory, Graphite and Androyen Systems. These systems were easily identifiable in the field by their component lithologies, but their age and stratigraphic relationships remained uncertain. The historical subdivisions were changed by GAF-BGR in 2008, who divided South Madagascar into three geological domains – Vohibory, Androyen and Anosyen – each composed of a different group of stratified and intrusive gneisses and a distinctive history of metamorphism.

For personal use only



**Figure 5.2: Map Showing the Geological Domains and Sub-Domains of Madagascar after GAF-BGR, 2009**

For personal use only

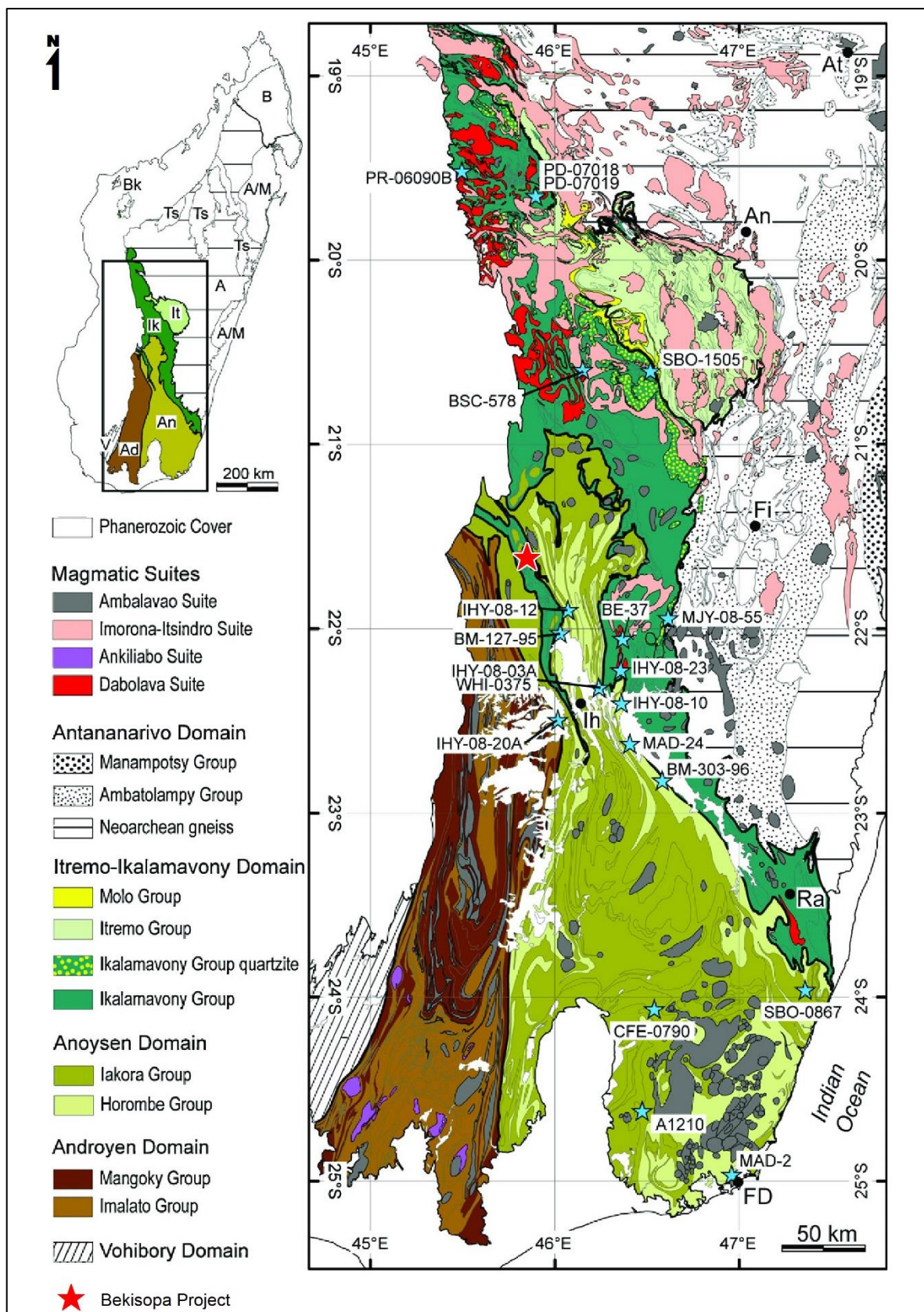


Figure 5.3: Geological Map of South Central Madagascar after Tucker et al, 2011

For personal use only

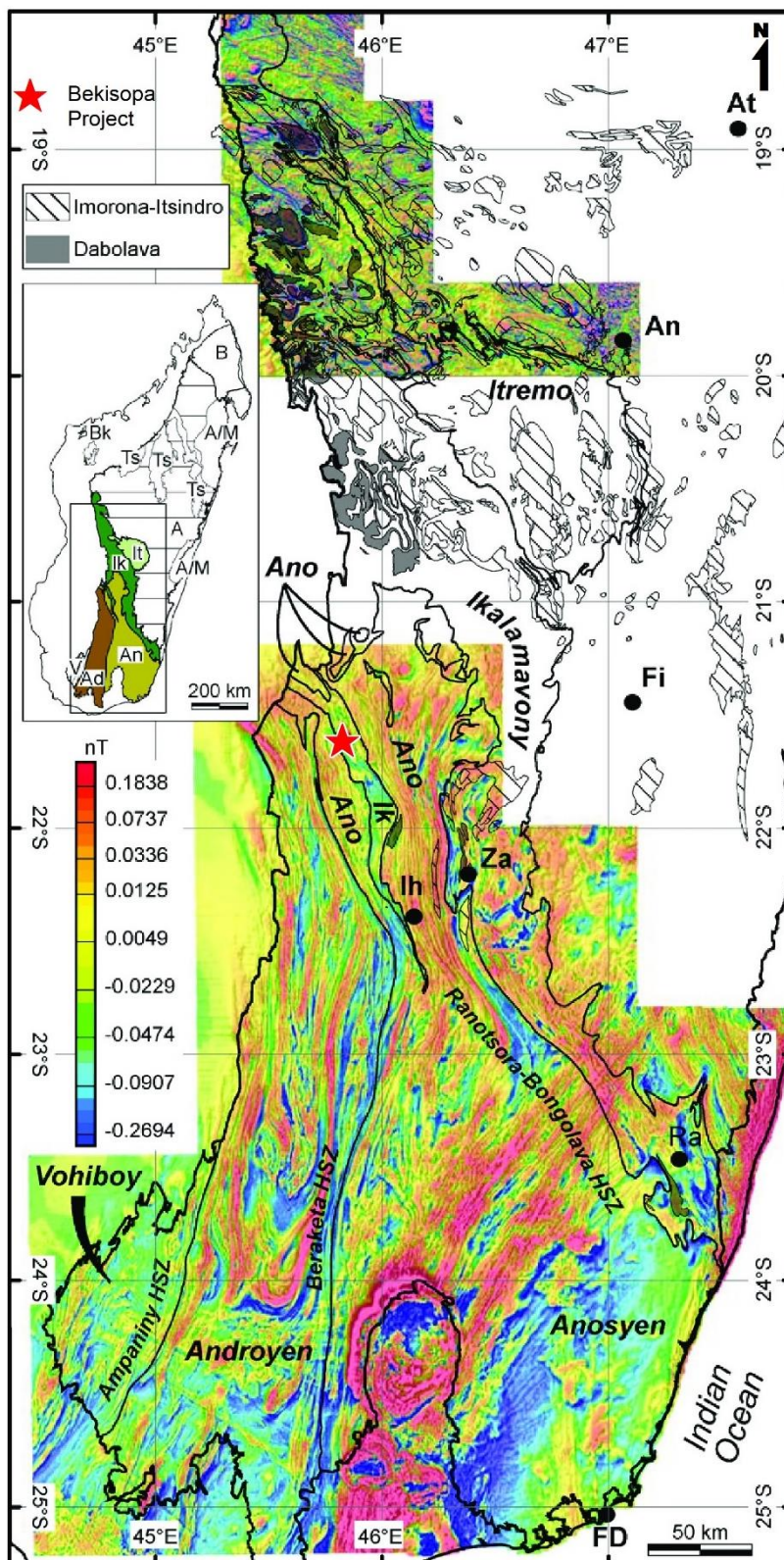


Figure 5.4: Total Magnetic Intensity Image of South Central Madagascar after Tucker et al, 2011

The new domains are separated by two north-south trending steeply dipping corridors of highly strained metamorphic rocks – the Ampanihy and Baraketa high strain zones as well as an irregularly shaped zone of highly strained and mylonitic rocks that roughly follows the Ranotsara plain. The Vohibory Domain, in the west consists of mafic and felsic orthogneiss with intercalated paragneiss and marble. Deformation and metamorphism in the Vohibory are different from most of Madagascar in that the domain experienced peak metamorphism (630-600Ma) at high pressure (9-11.5kbar) and high temperature (750-800°C), well before metamorphism occurred in the Anosyen and Itremo-Ikalamavony domains.

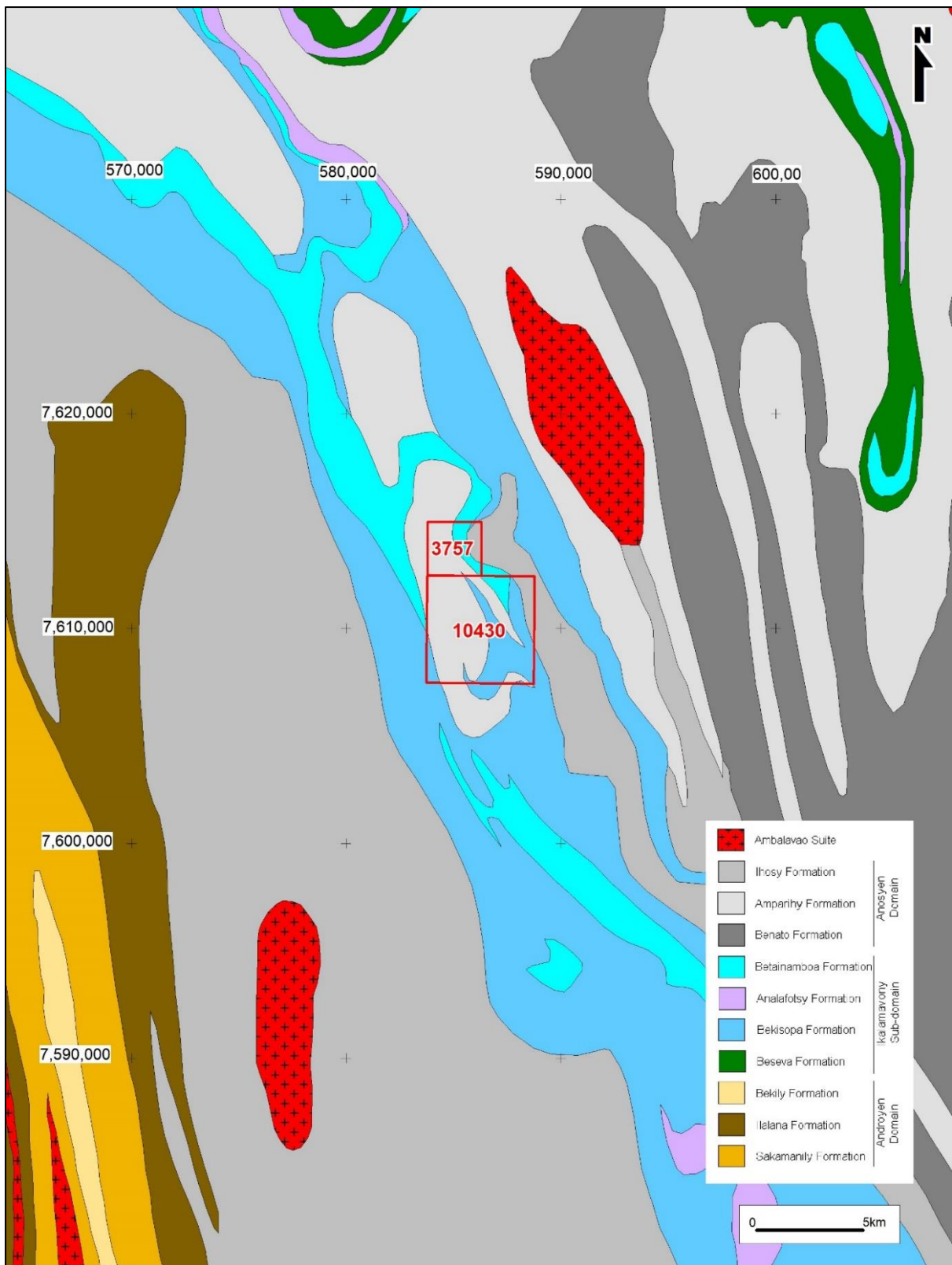
The Androyen Domain consists of two groups of stratified rocks (Mangoky and Imaloto Groups). Stratified rocks of the Mangoky Group consist of psammitic and pelitic paragneiss (±abundant graphite and sillimanite) as well as intermediate to mafic paragneiss. The Androyen Domain experienced two periods of metamorphism, one between 620 and 600Ma (835±20°C, 7kbar) and the other between 570 and 530 Ma (550-600°C, 4-5kbar).

The intercalated metavolcanic rocks of the Imaloto Group consist of quartzo-feldspathic gneiss of mostly rhyolite composition. The vast Anosyen Domain is consisting of two groups of volcanic and sedimentary rocks (Horombe and IAkora Groups). Both the Horombe and IAkora Groups were metamorphosed to granulite grade and intruded by granitoids of the Ambalavao Suite and the preserved metamorphic conditions are some of the highest in Madagascar (895-900°C, 9-10kbar). Thus, the Anosyen and Androyen Domains are distinguished by their (i) distinctive supracrustal rocks and (ii) different histories of metamorphism and deformation (Tucker et al, 2011).

## 5.2 Local Geology

The Bekisopa property occurs within the Anosyen Domain and Ikalamavony sub-domain of Madagascar. More specifically Permits PRE 3757 and PR 10430 occur within the Ihosy and Amparihy Formations of the IAkora Group (Anosyen Domain) and the Bekisopa and Betainamboia Formations of the Ikalamavony Group (Ikalamavony Sub-domain). To the north-east and south-west of the permits are intrusions of the Ambalavao Suite (Figure 5.5).

For personal use only



**Figure 5.5: Geological Map of the Bekisopa Area after GAF-BGR, 2008**

The Akora Group includes the non-felsic volcanic meta-sedimentary rocks of the Anosyen Domain. The Amparihy Formation rocks are characterised by a distinctive and well-developed stromatic migmatitic layering, but are otherwise largely homogeneous. In most cases the Amparihy Formation is characterised by biotite- and garnet-bearing gneisses. Quartz, K-feldspar and plagioclase are also present, as are ilmenite and more locally hercynitic spinel. More aluminous rocks are less common but present, and these additionally contain sillimanite or sillimanite and cordierite. The abundance of hercynite is typically higher in the more aluminous rocks. There is little compositional difference between the Amparihy and Ihosy Formations, even though these are notable differences in the mineral assemblages from each formation. The differences reflect the speciation of iron.

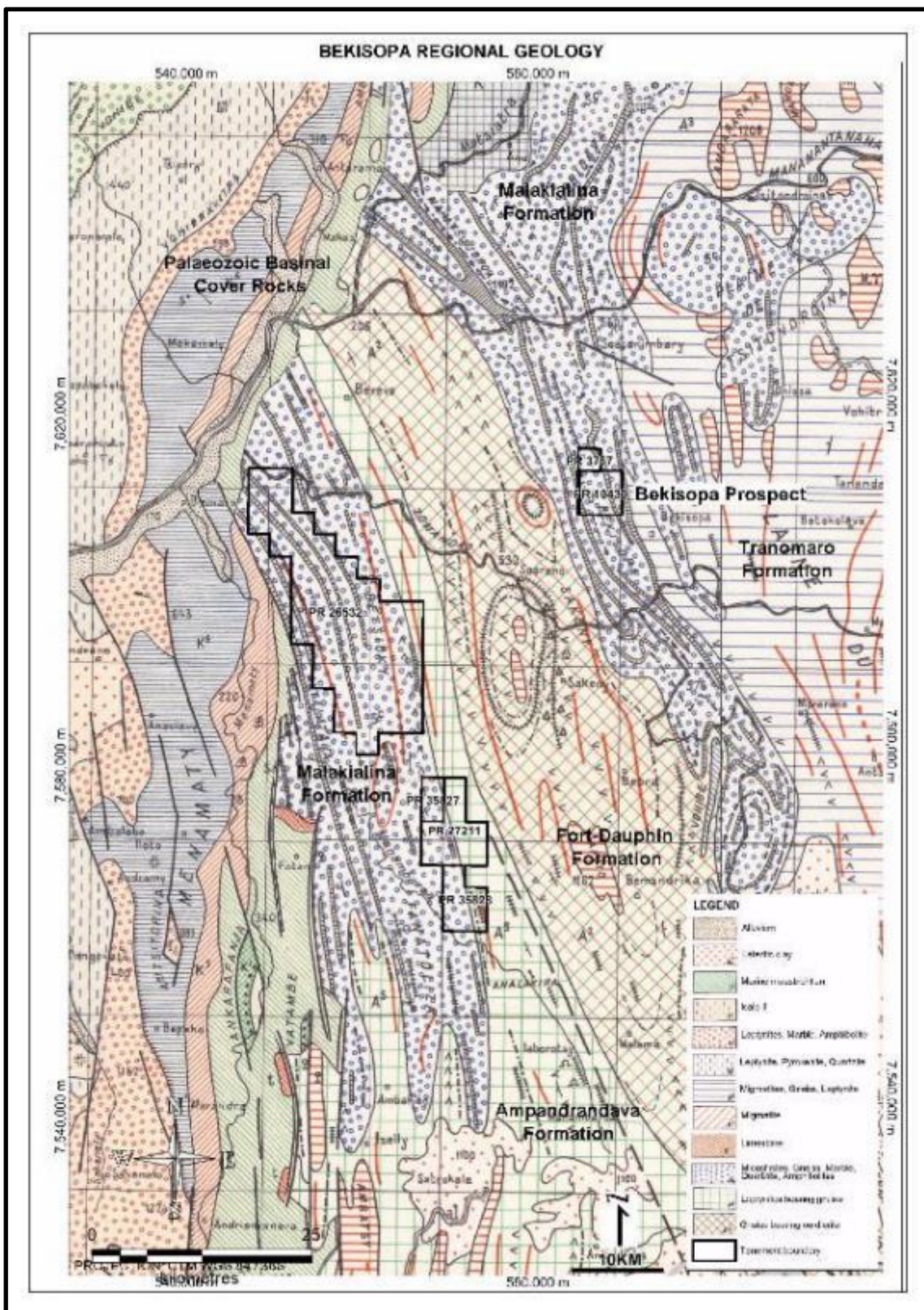
The Ihosy Formation rocks are also characterised by a distinctive and well-developed stromatic migmatitic layering. Cordierite and magnetite are conspicuous in these rocks and are present in abundances of between 25-50% and 3-10% respectively. These rocks are often garnet absent and contain the assemblage cordierite + sillimanite + biotite + plagioclase + K-feldspar + quartz + ilmenite and magnetite. Hercynitic spinel is also commonly present. More locally, rocks of the Ihosy Formation are orthopyroxene bearing. In these rocks garnet and sillimanite are commonly absent and the mineral assemblage consists of cordierite + orthopyroxene + biotite + plagioclase + K-feldspar + quartz + ilmenite and magnetite ( $\pm$  hercynitic spinel). The rocks have strikes of northwest-southeast and are characterised by tight to isoclinal folds, mostly showing sub-vertical dips (GAF-BGR, 2008).

The Iklamavony Group includes a sequence of mostly intermediate to mafic paragneisses, calc-silicates, metabasalts, marbles and quartzites that are interleaved with regionally extensive sheets of felsic orthogneiss of the Iklamavony Sub-domain. The rocks of the Bekisopa Formation consist predominantly of massive, medium to coarse-grained amphibolites. The most common rock types include epidote amphibolites, hornblende gneiss and pyroxenite. The epidote amphibolites contain the assemblage hornblende + plagioclase + epidote and quartz, while the hornblende gneisses are hornblende ( $\pm$ biotite) and plagioclase bearing rocks. The amphibolites can also contain garnet, pale green to colourless diopsidic clinopyroxene, hornblende and plagioclase.

The Bekisopa Formation is intercalated with kilometre scale layers of quartzite, impure marbles (Betainambo Formation), and quartzo-feldspathic gneisses. These rocks of the Betainambo Formation are medium- to coarse-grained and mainly massive, however weak millimetre to metre scale compositional banding defined by layers of oxides is also locally present. In addition to calcite and/or dolomite, these rocks locally show scapolite and plagioclase or clinopyroxene and plagioclase rich layers. The rocks have strikes of northwest-southeast, and are characterised by folds which mostly shows dips to the west (GAF-BGR, 2009).

The general mapping data is excellent and it can be seen that the Malakialina Formation (Figure 5.6) is the main host of iron mineralisation in the district, and within the project area is comprised of a sequence of mica schists, gneiss, marble, quartzite and amphibolite.

For personal use only



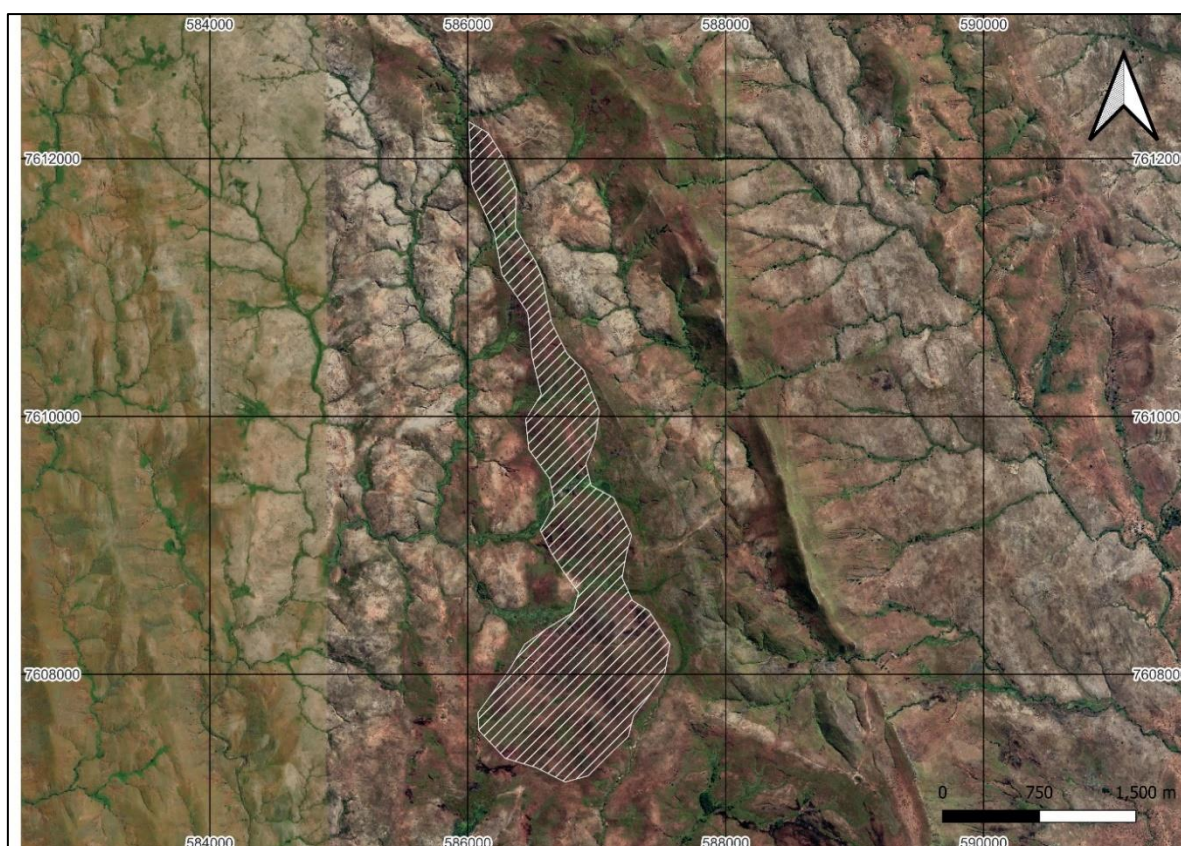
**Figure 5.6: Geological Map of the Bekisopa Area**  
Original Licences shown as Black Outlines (26532 & 35828 Relinquished)

The quartzites form very well-defined ridges in the region and these are highlighted by hatching on the geology plan (Figure 5.6). Granites and migmatites appear to intrude all formations in the district. Tight to isoclinal folding can be seen as defined by the quartzite outcrops and magnetics.

### 5.3 Deposit Geology

The local geology consists of a calc-silicate unit within schists and gneisses. The calc-silicate unit appears to be a favourable host for deposition of iron mineralisation from metasomatic fluids derived from either magmatic or metamorphic processes. As is normal for high grade metamorphic rocks, the units show evidence of complex deformation including several generations of folding. There is some evidence of an early isoclinal folding and this can be seen in both outcrop and regional scales.

Satellite imagery clearly shows the surface expression of the iron mineralisation as a red/brown unit (Figure 5.7). It can also be seen in the satellite imagery, that this unit forms a moderate topographic high, but this is not as pronounced as the quartzite unit in the east of the licence area.



**Figure 5.7: Satellite Imagery Showing Surface Expression of Iron Mineralisation (Red-brown Fe-rich unit outlined in White)**

On the ground, it can be seen that the colour anomaly is due to outcropping to subcropping massive magnetite-hematite, plus overlying magnetite-hematite and minor limonitic-goethitic regolith, canga (consolidated iron rich gravel) and red soil containing common magnetite and hematite sand sized particles (Photo 5.1 to Photo 5.2) and Photo 5.3.

For personal use only



**Photo 5.1: Outcrop of Magnetite-Hematite (showing remnant structure) and Red Gravel-Soil Weathering Product**



**Photo 5.2: Magnetite Particles on Hand Magnet from Red Soil**



**Photo 5.3: Creek Exposing Red, Iron-Rich Regolith at Bekisopa South**

While this has all previously been interpreted as surficial enrichment, the presence of primary textures within the massive magnetite-hematite outcrops such as banding/bedding and alteration zones around fractures (Photo 5.4 to Photo 5.5) suggests this may in fact be primary mineralisation, possibly with some weathering that has converted a small portion of the magnetite to hematite. The limonitic/goethitic laterite, canga and red soil may form secondary iron-ore mineralisation, although grade is generally lower than the massive magnetite-hematite mineralisation, which has been shown to grade between 60% and 67% Fe.

For personal use only



**Photo 5.4: Outcrop of Massive Magnetite+/-Hematite**



**Photo 5.5: Outcrop of Massive Magnetite with Magnetite Rich Layer, after Akora Resources**

The main mineralisation appears to consist of massive magnetite-hematite bands between a few metres and up to 20 - 50m in width, within a generally magnetite bearing sequence of calc-silicates and magnetite rich schist and gneiss that may be over 100m wide in places. The iron mineralisation occurs dominantly as magnetite although some hematite is noted, in particular within near surface environments suggesting this may be due to later alteration/oxidation. Hematite is observed more frequently in the Southern Zone.

#### 5.4 Style and Morphology of Mineralisation

The iron mineralisation at Bekisopa is predominantly magnetite-based and the following main ore types have been identified:

- DSO - near surface high grade weathered zone consisting of a mixture of hematite and magnetite mineralisation with grades of around 60% Fe.
- Massive magnetite – found below the DSO and comprising weathered and unweathered mineralisation with grades of around >45% Fe.
- Disseminated:
  - Coarse disseminated with grades of around 30% - 45% Fe; and
  - Fine disseminated with grades of around 25% Fe.

The mineralisation has the form of a tabular zone or zones and trends from steeply westerly dipping in the north to moderately westerly dipping in the centre and moderately to flat dipping in the south. Faulting is not apparent on a large scale, but may be present on a smaller scale that has not been identified with the current drill spacing. East-west faults, represented by small valleys separating the three zones, are hypothesised and require further investigation.

Oxidation is variable, but generally complete oxidation is between 5 and 20m below surface and partial oxidation (generally around fractured zones only) is irregular. There has been some iron enrichment in the oxidised zone due to removal of host rock material via weathering, and there is strong potential for DSO at +58% Fe in the upper, completely oxidised zone and in surficial scree derived from this material.

#### 5.5 Deposit Model

Iron mineralisation at Bekisopa is believed to be of metasomatic origin and preferentially hosted by calc-silicate rocks within a high-grade metamorphic sequence.

The lack of any magnetite-quartzite along the entire 7km of iron mineralisation tends to suggest that this is not a typical Algoma-style BIF deposit similar to those interpreted at Akora's other iron ore projects Tratramarina and Ambodilafa. Instead, the main mineralisation appears to consist of massive magnetite-hematite bands between a few metres and up to 20 - 50m in width, within a generally magnetite bearing sequence of calc-silicates. However, there are similarities with the Algoma-style, such as the bedding/layering controlled nature of the iron mineralisation although there is a lack of any chert at Bekisopa.

Iron oxide apatite (IOA) type of deposits, also referred to as Kiruna-type deposits, and IOCG deposits are characterised by abundant low-Ti Fe oxides, an enrichment in REE, and intense sodium and potassium wall-rock alteration adjacent to the ores (Westhues et al., 2012). This differs from what is observed at Bekisopa, where no wall rock alteration is present.

A possible analogue to Bekisopa is the Horto-Baratinha (HBD) and Cuité (CTE) high-grade iron ore deposits (>60% wt. Fe) located in the Guanhães Tectonic Block (GB), at the eastern margin of the São Francisco Craton bordering the late Neoproterozoic–Cambrian Araçuaí–West Congo Orogenic belt (Braga et al., 2021). The iron orebodies are hosted by metamorphic banded iron formation (IF) with associated quartzite and aluminous schists and occur within gneissic rocks and granitic plutons. The Guanhães Tectonic Block was intruded by pegmatites which led to the development of massive, granular magnetite-rich high-grade orebodies at the contact zone.

Whole-rock data indicates that the massive hematite-magnetite high-grade iron ore pods exhibit Fe contents between 50.24 and 69.46 wt%, and increasing content of  $Al_2O_3$ , MgO and CaO and the trace elements Zr, Y, Zn, and Ni near the contact with pegmatite, associated with the presence of interstitial silicates and carbonates in their composition. Pegmatites are mapped at Bekisopa but their lack of alteration implies a lack of influence on the iron mineralisation.

Skarn deposits are characterised by magnetite hosted in calc-silicate contact metasomatic rocks. Calcic-type magnetite skarns are formed in island-arc settings, typically associated with mafic intrusions. Conversely, magnesian-type magnetite skarns are formed in orogenic belts along continental margins, and are typically associated with felsic plutons and dolomitic host rocks, or in districts that contain copper or tungsten skarn deposits (Hammarstrom et al., 1986). A third type, scapolite-(albite) iron skarn deposits, are the most important iron host, and are found in basinal volcanic-sedimentary strata, with a direct, genetic relation to late-stage mafic magmas, typically in ocean-arc settings.

Iron skarns are characterised by magnetite as the principal ore mineral, with ore grades commonly between 40wt% to 50wt% iron and with relatively low sulphide mineral contents. Minor quantities of Cu, Co, Ni, and Au may be present, but Fe is typically the only commodity recovered (Grigoryev et al., 1990). The host rocks are typically calcareous units, fine grained siliciclastics and associated with diorites or dolerites.

Further investigation (including drilling and petrology) is required to better understand and classify the geology of the Bekisopa Iron Project.

## 6 EXPLORATION

### 6.1 Historical Exploration

Mineralisation was apparently first noted in 1933 during the course of regional mapping and was followed by a revision of the geology in 1955. Over the last 60 years, a considerable amount of exploration work has been carried out in the region of the main Bekisopa licences (PR 10430 and PRE 3757).

At Bekisopa, two historical exploration programmes have been undertaken - first by BRGM from 1959 - 1962 and then by the UNDP from 1976 - 1978.

Between 1959 and 1962, BRGM carried out an exploration and evaluation work programme at Bekisopa including geological mapping (Figure 6.1), geophysical surveying, extensive trenching and pitting, drilling, petrology and geochemical and metallurgical analysis.

The works by BRGM included:

- 564 pits representing a total length of 1,862m;
- 4,000m of trenching;
- 22 boreholes with a total length of 572m; and
- 2,581 samples sent for analysis.

Additional detail is outlined below, and shown in Figure 6.2:

- During the BRGM work, trench samples were collected as 1m horizontal channels, with two or more samples collected if the lithology changed. Pit samples were collected as 1m vertical channels, with each channel sample 20cm wide by 10cm deep;
- Samples collected by BRGM were crushed and ground to minus 0.15mm in country, and then a 200g split was sent to either BRGM in Paris or Dakar, or to the Department of Mines for Madagascar in Antananarivo, for analyses for Fe, SiO<sub>2</sub>, Al<sub>2</sub>O<sub>3</sub> and P; and
- In regard to the BRGM drilling, near surface core recovery was generally low, and samples were collected both from the core and the cuttings. Below the surficial zone (10m - 30m) recovery is much better (50 - 100%). Drill logs are available and appear to be of high quality, with logging and assaying confirming each other as expected for the very visually distinct iron mineralisation. The original drill locations appear to be very good (+/- 5m accuracy).

For personal use only

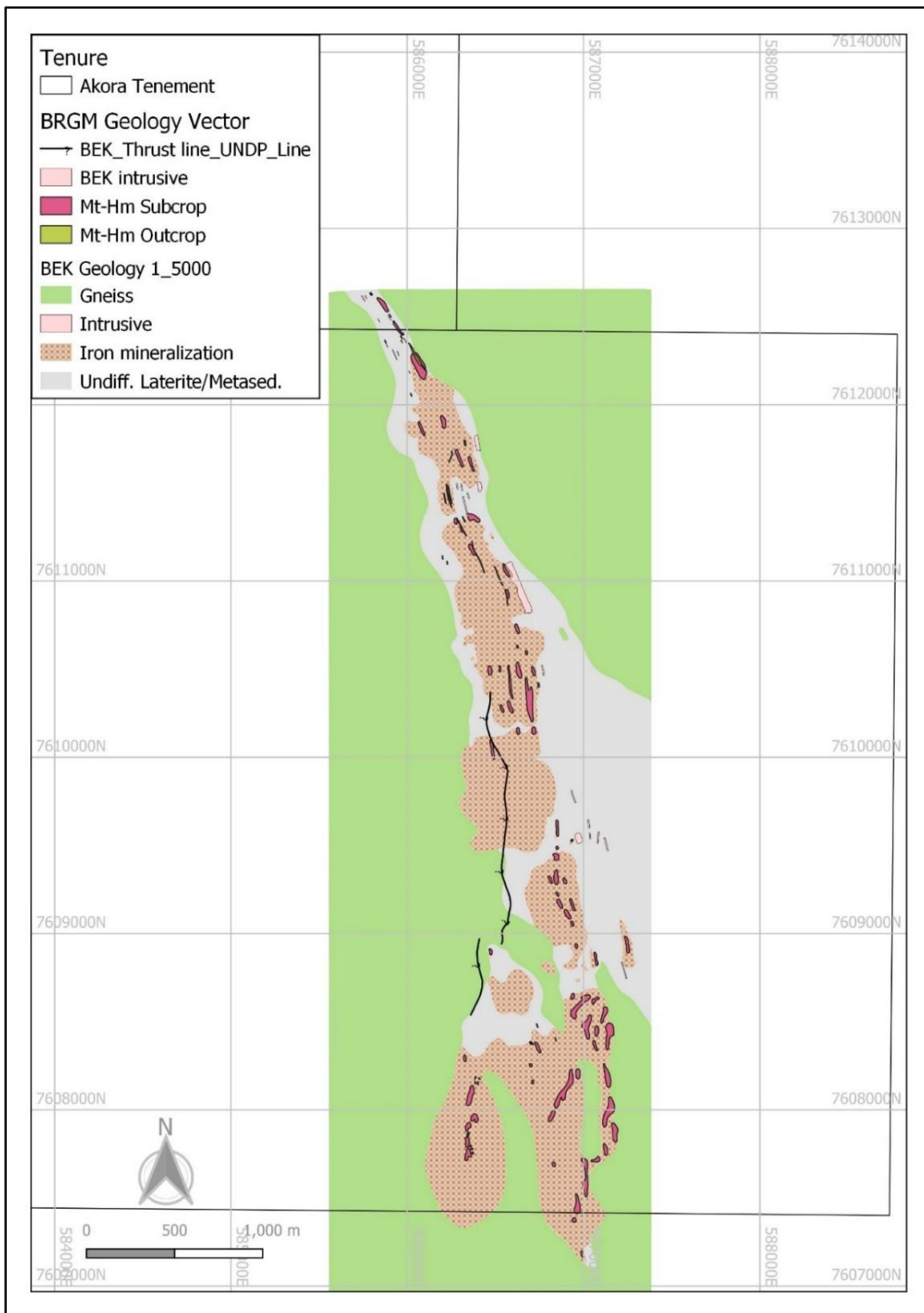


Figure 6.1: BRGM Geological Mapping at Bekisopa

For personal use only

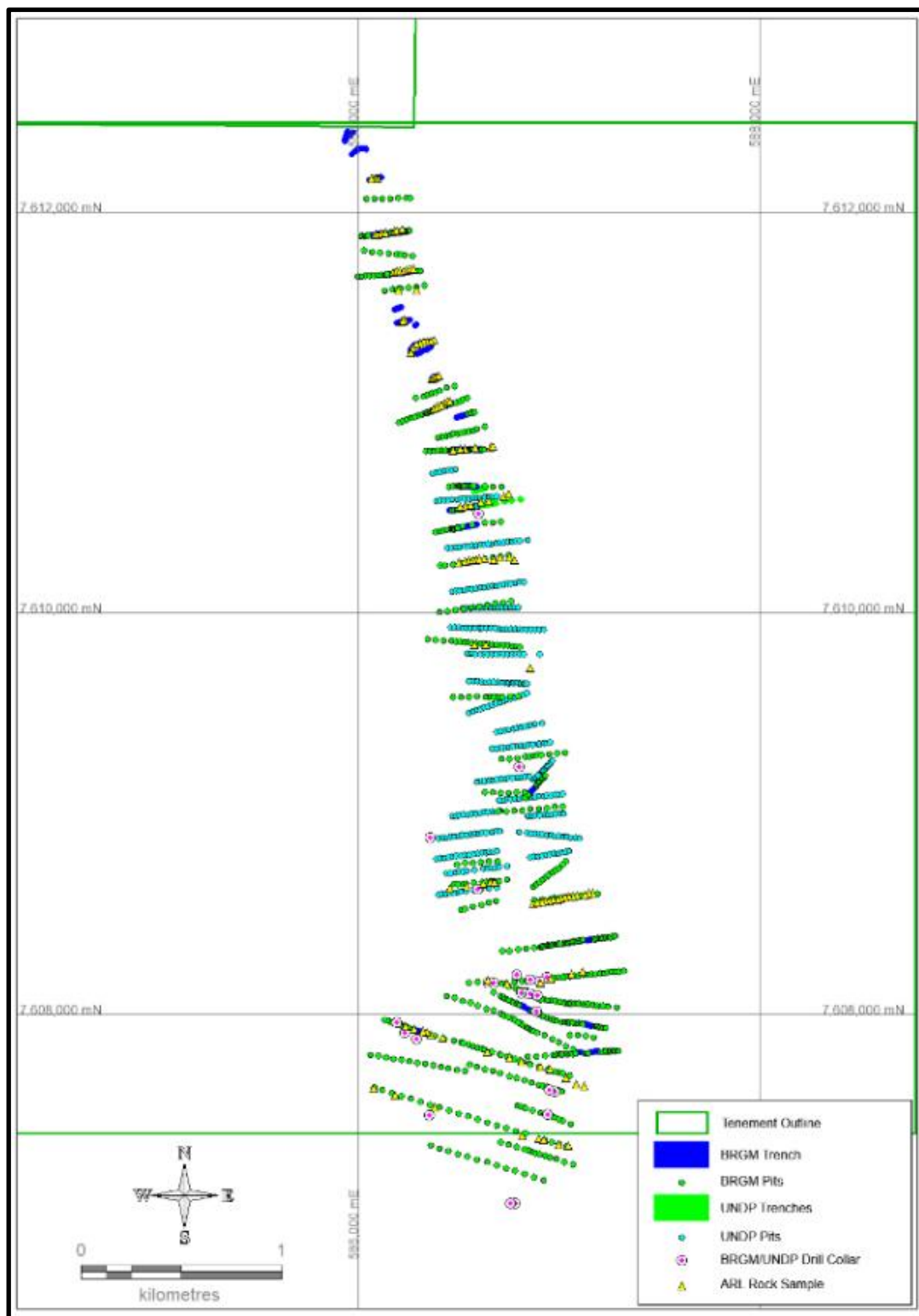


Figure 6.2: Plan View of Historic Trenches and Pits, and Recent Sampling by AKORA

Between 1976 and 1978, the UNDP carried out similar exploration work, including two additional drillholes, and re-evaluated the BRGM studies. The work carried out was thorough and certain aspects of could potentially still be utilised including many of the excavations, trenches and pits which are still open, although largely choked with vegetation.

Between the UNDP study in 1978 and Akora exploration work beginning in 2014, evaluation work on the Bekisopa project was largely confined to revisiting the BRGM and UNDP data sets, improved geophysical surveys and re-interpreting the geology.

More recent work as part of the Project de Gouvernance des Ressources Minerales (PRGM) project has resulted in a wholesale reinterpretation of the Geology of Madagascar, which now places the age of the geology and mineralisation at Bekisopa as Palaeoproterozoic, one of the most favourable times for formation of iron deposits.

Additional geophysical work was carried out by Cline Mining in the years that they held the relevant licences (2005 – 2010). Cline Mining initially concentrated their efforts on geophysics with the World Bank funded airborne magnetic and radiometric survey, carried out by FUGRO, as their starting point.

Utilising a consultant out of Toronto they carried out a full interpretation of these data. Further ground geophysical surveys including gravity, magnetics and ground penetrating radar, provided further data.

## 6.2 Akora Exploration 2014 -2019

Akora acquired the project during 2014, and between 2014 – 2019 work consisted of:

- Data compilation and interpretation;
- Confirmatory rock chip sampling (118 samples) and mapping;
- Re-interpretation of airborne geophysical data; and
- Ground magnetic surveying (305-line kilometres).

The rock chip sampling confirmed the high tenor of the mineralisation at and near surface, with the 118 samples collected from pits, subcrop and outcrop, averaging 66.7% Fe, 1.5% SiO<sub>2</sub>, 1.0% Al<sub>2</sub>O<sub>3</sub> and 0.075% P, over the full 5km sampled.

This confirmed the previous work and showed very high-grade mineralisation located at and near surface with very low levels of penalty elements.

The mineralisation is generally massive magnetite that has been partially altered to hematite in places and forms a good quality “lump” mineralisation ideal for blast furnace feed.

Geological mapping showed that the massive magnetite-hematite mineralisation varies from a few metres up to >20m (possibly to over 100m in areas of rubbly subcrop) in width and that several bands are present in most areas.

These bands generally grade more than 60% Fe and up to almost 70% Fe in places, as shown by the rock chip sampling completed by Akora (see Figure 6.3), and the previous pit, trench and drillhole sampling by BRGM and UNDP. In between the massive magnetite-hematite bands are zones of “disseminated” magnetite within amphibolites and calc-silicates. These generally grade between 30% and 60% Fe.

For personal use only

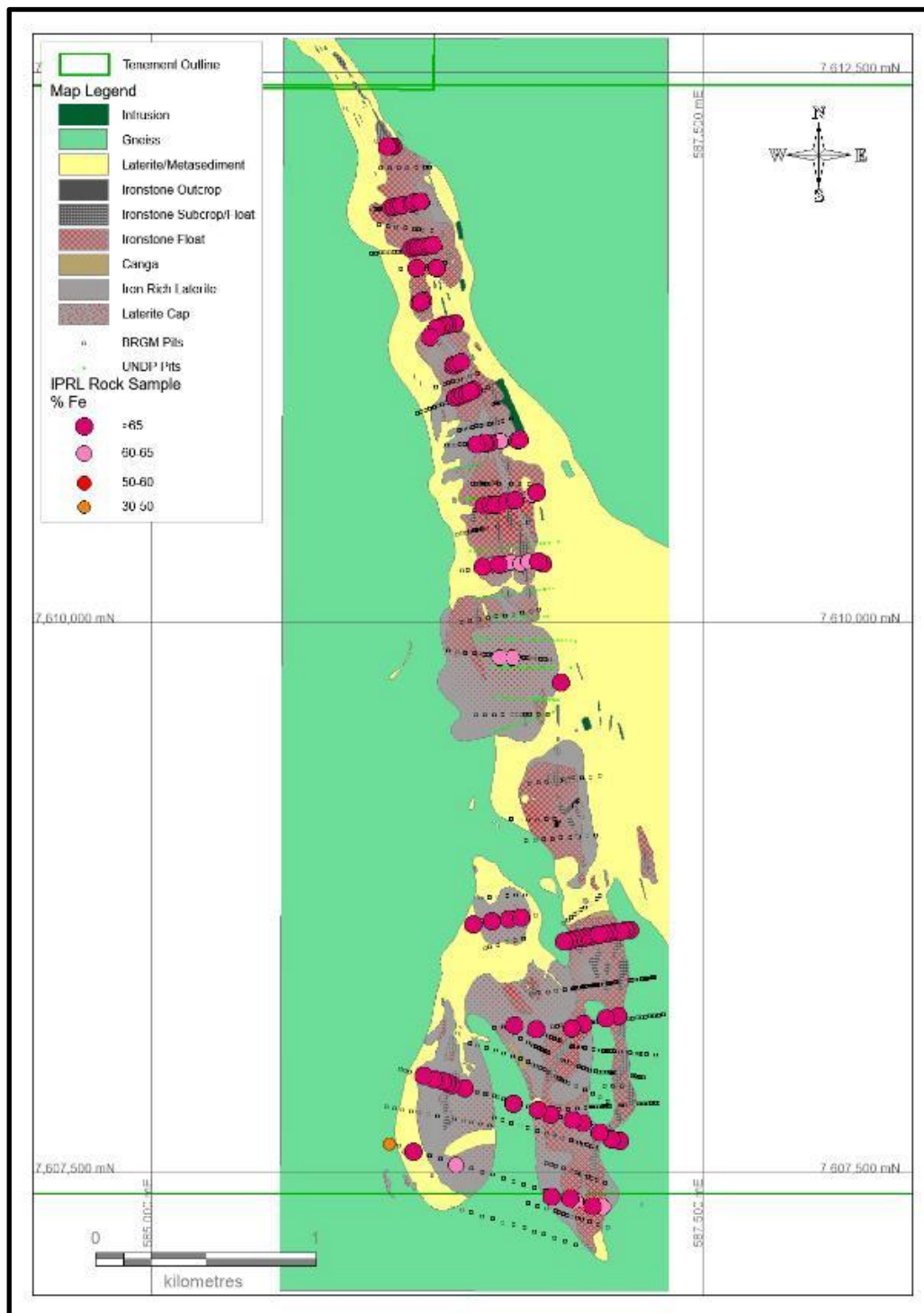


Figure 6.3: Akora Rock Chip Sampling Results

In 2019, a ground magnetic survey was commissioned by Akora using Planetary Geophysics personnel and equipment along with Akora's own in country personnel. The data was subsequently imaged and modelled by Planetary Geophysics, Australia.

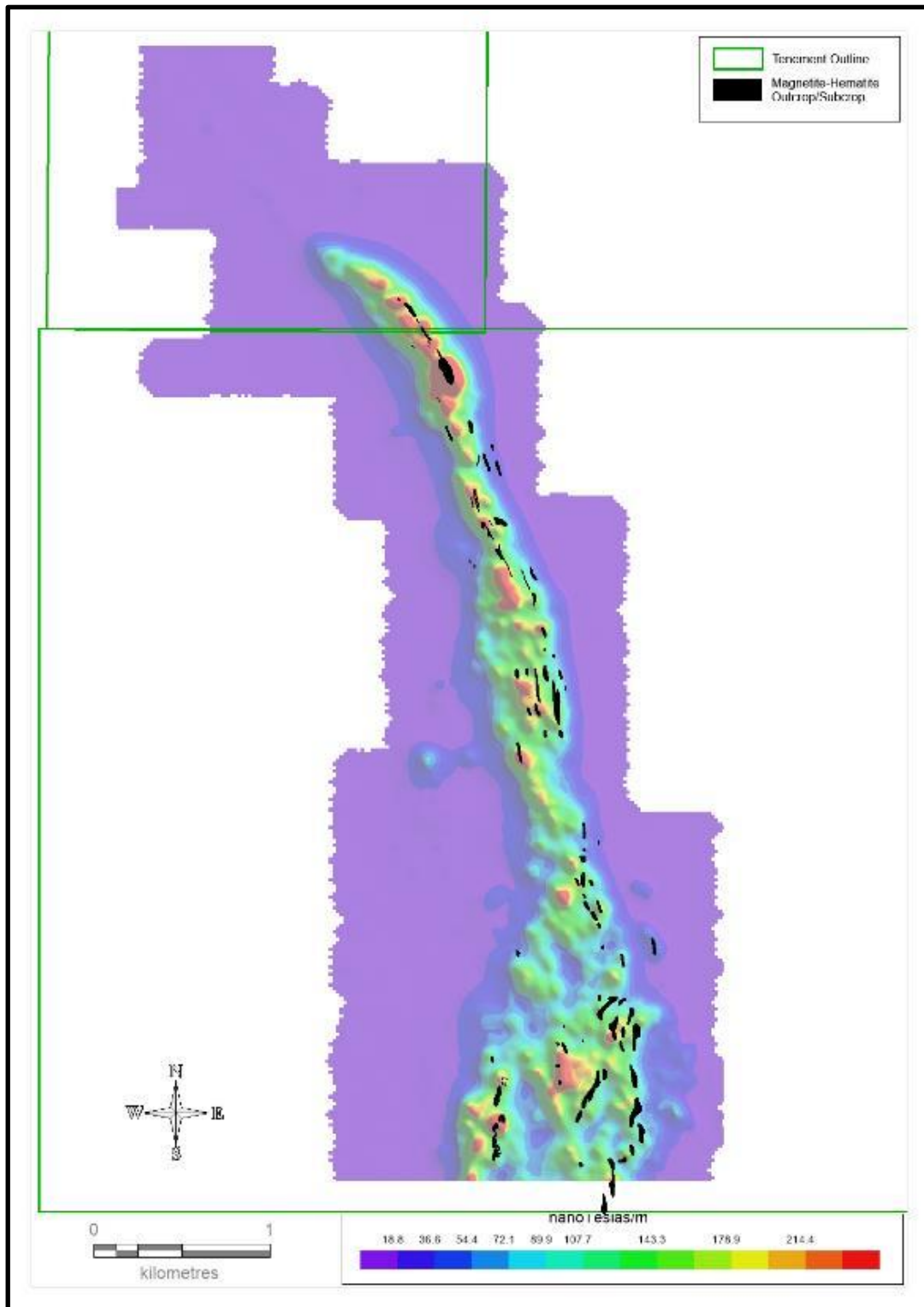
The data, while noisy (as expected) due to very magnetic material at surface, defined a good magnetic anomaly over the mapped iron mineralisation.

The colour anomaly identified on the satellite image (Figure 5.7) has been superimposed on this image and is an excellent match with the magnetic anomaly. The anomaly is coincident with mapped high-grade iron mineralisation as shown in Figure 6.4, which overlays mapped magnetite-hematite outcrops on the magnetic anomaly. The magnetic data indicates that the iron mineralisation at Bekisopa appears to be a "string of pearls" rather than a continuous stratigraphic horizon, and that this is the highest order anomaly in the entire area.

The combined geological and geophysical data has been used to interpret the iron mineralisation. The stratigraphy is complex with tight folding and several dislocations that are probably due to faulting. While stratigraphy appears simpler in the north than in the south, it is likely that the magnetite bearing stratigraphy is isoclinally folded, possibly resulting in an apparent thickening and/or repeating of the iron-ore bearing lithologies.

Modelling of the geophysical data confirms the Akora interpretation and shows some strongly remnant magnetised areas and hence confirms that the analytical signal is the best way to examine the data as it shows these remnant magnetised areas as highs rather than lows.

For personal use only



**Figure 6.4: Bekisopa Iron Project - Magnetic Image (Analytical Signal, Upward Continued 25m), Magnetite-Hematite Outcrop/Subcrop Shown in Black**

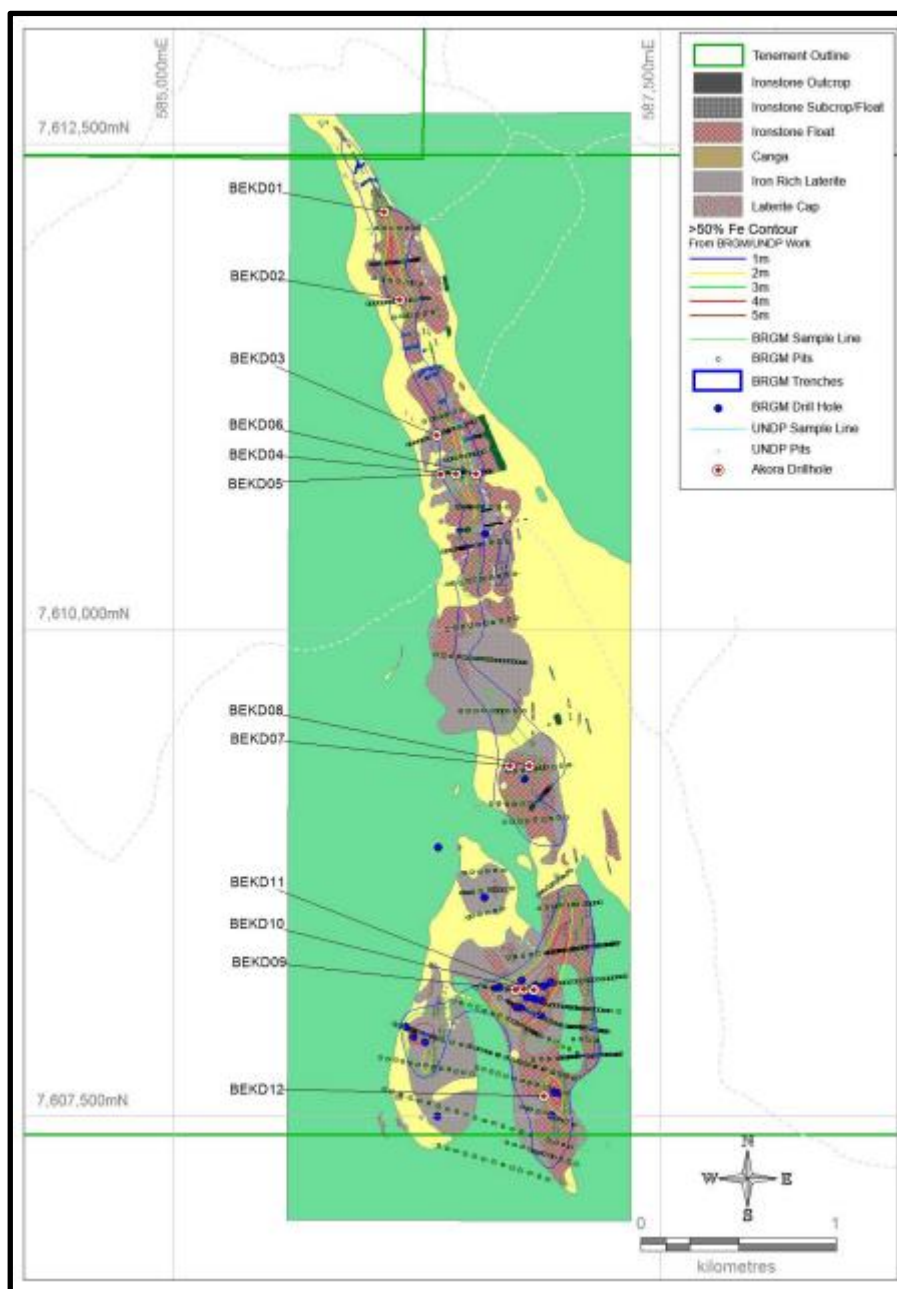
### 6.3 Akora Recent Exploration 2019 -2022

#### 6.3.1 2020 Drilling Results

Akora carried out diamond drilling in 2020 with 12 holes completed totalling 1,095.5m, namely BEKD001 to BEKD012 as shown in Table 6.1 and Figure 6.5.

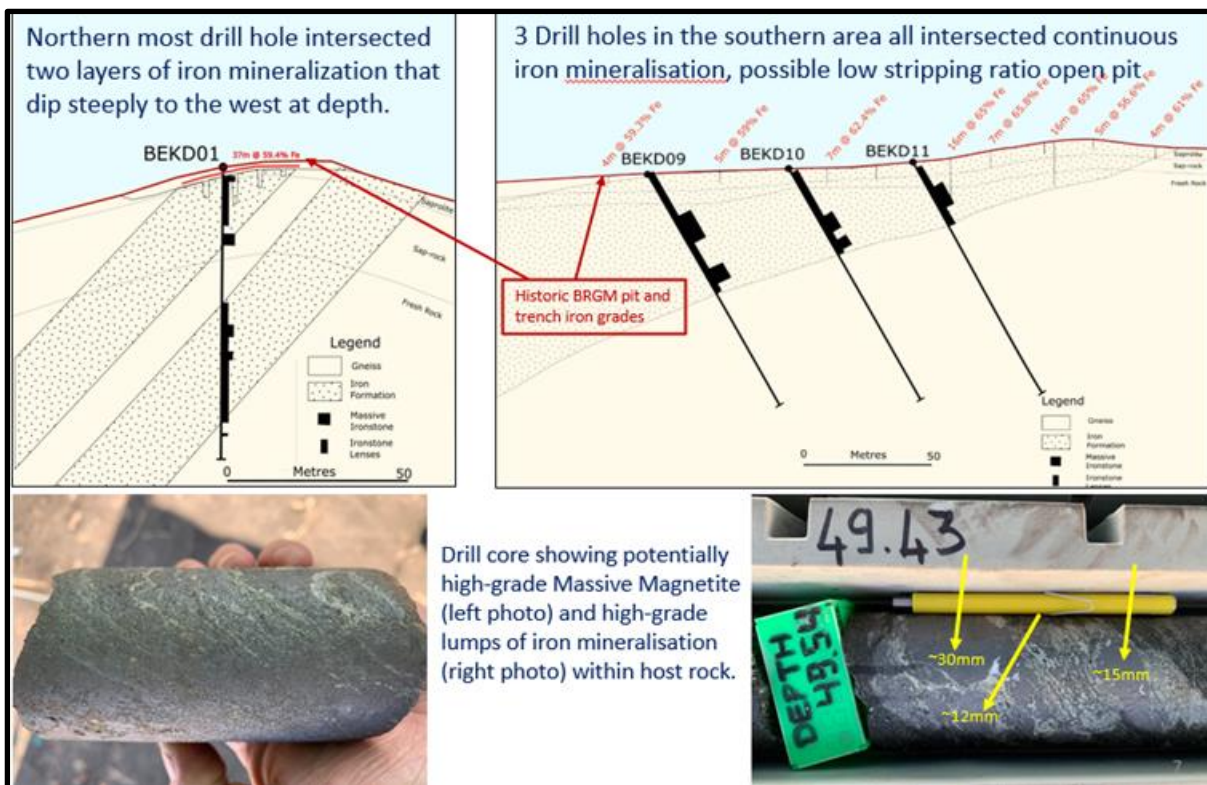
<b>Table 6.1: Summary of Holes Drilled 2020</b>									
No.	Project	Licence	BHID	X	Y	Z	Azimuth	Inc.	EOH (M)
1	Bekisopa	10430	BEKD01	586,079.14	7,612,149.63	881.57	0	-90	80.54
2	Bekisopa	10430	BEKD02	586,159.72	7,611,698.80	878.75	90	-60	80.48
3	Bekisopa	10430	BEKD03	586,348.61	7,610,999.93	872.47	90	-60	100.47
4	Bekisopa	10430	BEKD04	586,448.83	7,610,800.20	869.83	90	-60	100.49
5	Bekisopa	10430	BEKD05	586,368.86	7,610,799.03	862.45	90	-60	100.45
6	Bekisopa	10430	BEKD06	586,549.33	7,610,800.69	871.29	90	-60	60.40
7	Bekisopa	10430	BEKD07	586,722.86	7,609,300.53	842.30	90	-60	70.50
8	Bekisopa	10430	BEKD08	586,822.68	7,609,300.47	853.71	90	-60	100.44
9	Bekisopa	10430	BEKD09	586,749.33	7,608,150.00	862.81	90	-60	100.46
10	Bekisopa	10430	BEKD10	586,798.55	7,608,149.51	865.33	90	-60	100.43
11	Bekisopa	10430	BEKD11	586,848.77	7,608,150.06	868.22	90	-60	100.44
12	Bekisopa	10430	BEKD12	586,898.98	7,607,599.67	868.86	90	-60	100.42
<b>Total metres:</b>									<b>1,095.5</b>

For personal use only



**Figure 6.5: Location of 2020 Drill Holes**

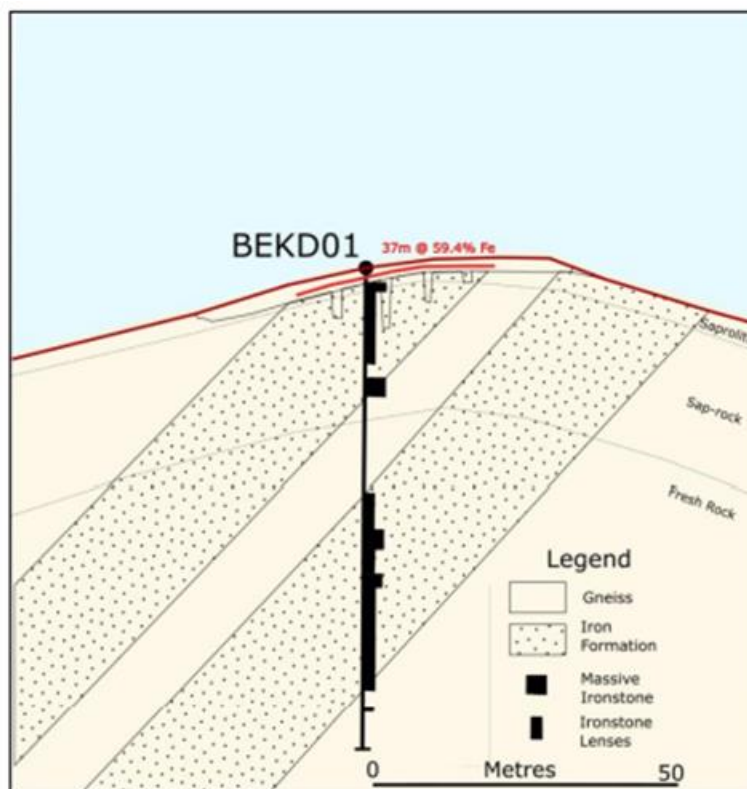
The drilling confirmed that mineralisation consists of layers, lenses, and pods (semi-spherical aggregates) of massive magnetite and hematite aggregates within the host rock of gneiss and calc-silicate, as illustrated in Photo 6.1.



**Photo 6.1: Drilling of holes BEKD01: BEKD09: BEKD10: BEKD11  
BEKD01 49.5m Close-up of Pods of Massive Magnetite  
(black mineral, examples shown with yellow arrows)  
in Calc-Silicate Host Rock (white and green minerals)**

The total combined width of the mineralised system in this drillhole is around 50m in two separate bands as shown in Figure 6.6.

These drill results and interpretations confirm that the pre-drilling understanding of massive bands of magnetite and hematite within a broader zone of “disseminated” lenticular and poddy magnetite mineralisation is correct along the more than 5-kilometre strike length. Interestingly, it appears that the “disseminated” iron mineralisation halo contains much coarser magnetite aggregates (lenses, pods and layers) and mineralisation in the country rock than previously thought.



**Figure 6.6: Interpreted Cross-Section Through BEKD01  
(Historical BRGM Channel Sample Assays from Trenching Shown in Red)**

The results show outstanding intersections and grades for the Bekisopa Project:

- Assays confirm continuation of significant, near surface, high-grade iron mineralisation in a shallow dipping mineralisation zone;
- Iron mineralisation is outcropping and is at least 45m true thickness, and importantly increasing in thickness with depth;
- LIMS test work delivered product grades of up to 66.9%Fe with potential for a high-quality premium DSO fines product; and
- Significant continuous iron mineralisation intercepts from surface, with 25.2m @ 61.4% Fe including 13.6m @ 63.5% Fe.

### **6.3.2 2021 Drilling Results**

Following on from the successful 2020 drilling campaign, the 2021 drilling campaign was implemented as outlined below.

The drill rig and camp mobilisation commenced on May 30th for the 2021 Bekisopa drilling campaign, see Figure 6.7, and drilling commenced on 13<sup>th</sup> June 2021.

The drilling consisted of shallow holes (BEKD13-BEKD22) drilled to depths of between 30m - 107m, with the initial focus in the southern zone around the 2020 BEKD09, BEKD10 and BEKD11 drill holes, and in the northern zones, along strike from the 2020 BEKD01 and BEKD002 drill holes, on the main Bekisopa 6km strike length.



Figure 6.7: Bekisopa Drill Camp

Iron mineralisation observed in the drill core from the holes contains what appears to be high-grade massive regolith-hosted mineralisation in the near surface intercepts, and extensive lengths of high-grade massive bedrock-hosted mineralisation at depth as shown in Figure 6.8.

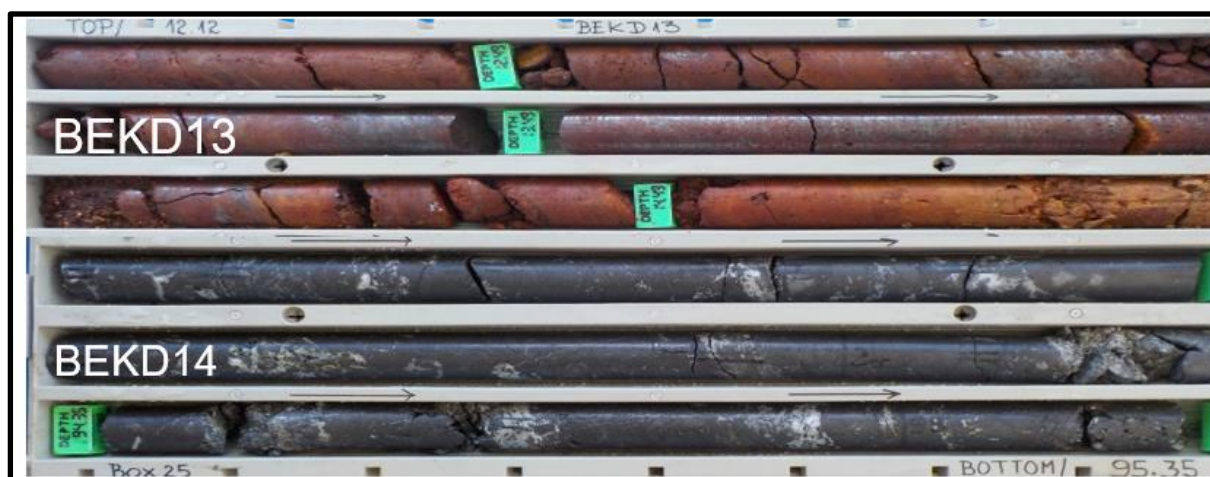
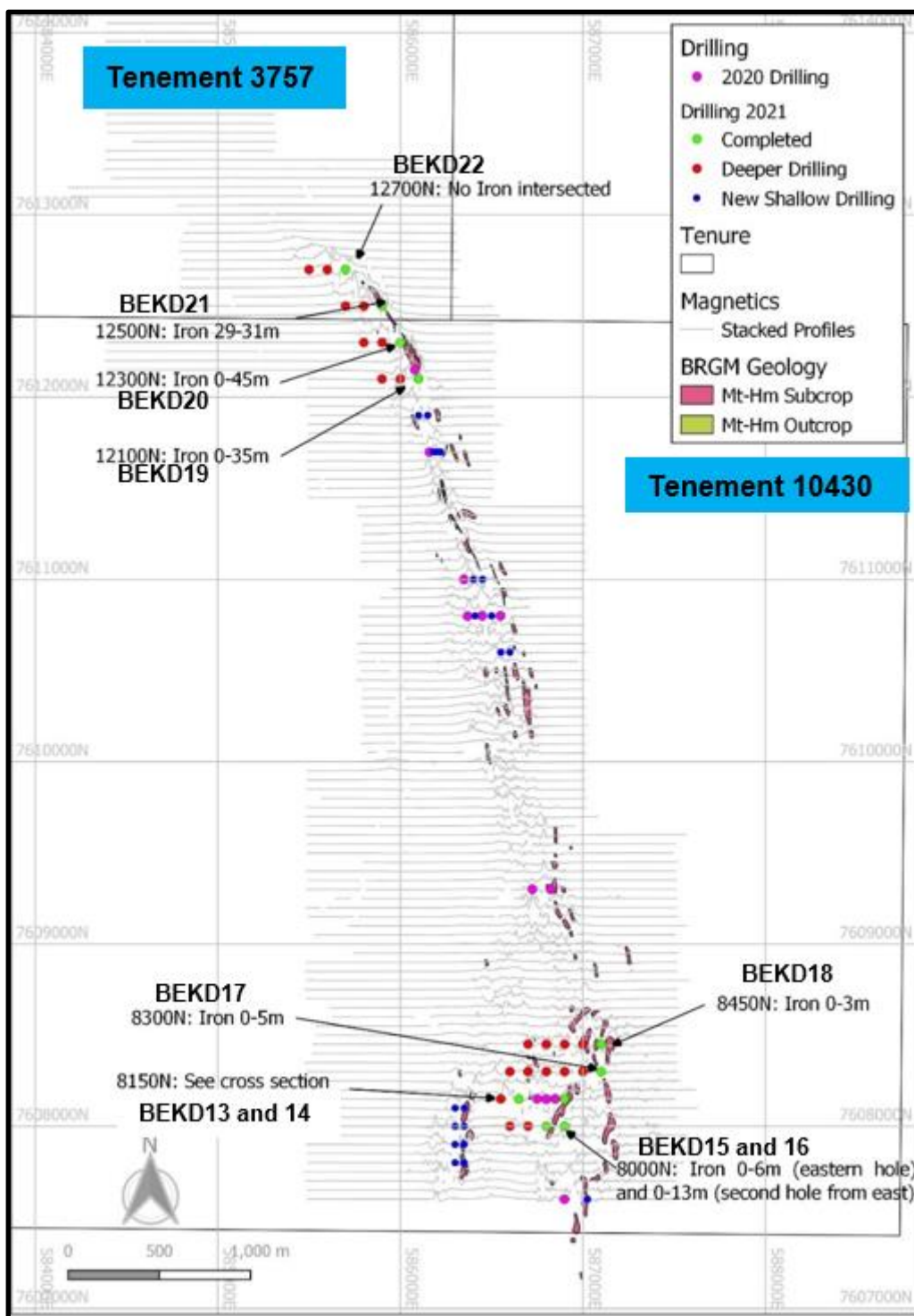


Figure 6.8: Recent Drill Core from BEKD13 and BEKD14

Regolith-hosted or weathered massive iron mineralisation was observed near surface, from 12.1 to 15m, in hole BEKD13 and high-grade massive mineralisation at an interval between 92.35 to 95.35m in BEKD14.

Figure 6.9 shows the location of the first ten 2021 drill holes, with their iron intercepts noted.

For personal use only



**Figure 6.9: 2021 Bekisopa Drilling Campaign Drill Hole Location Plan  
Showing the First 10 Drill Holes with their Iron Intercepts**

Table 6.2 shows the details of the first 10 drillholes and reported mineralisation.

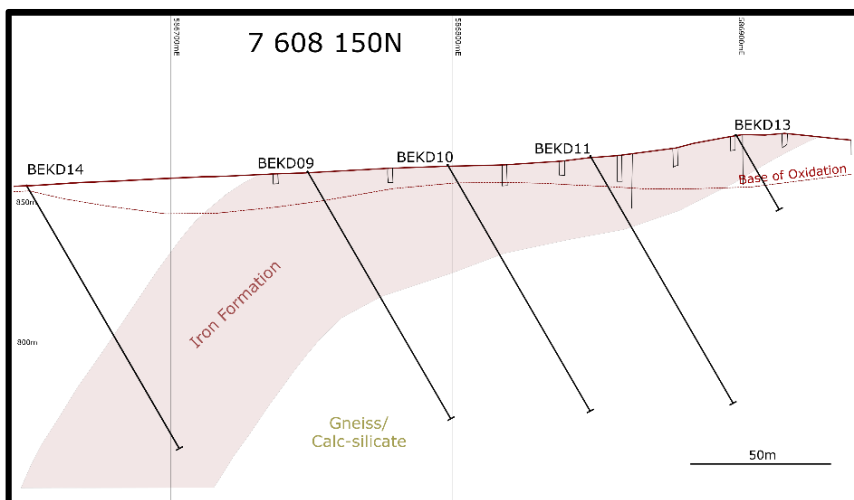
**Table 6.2: Bekisopa 2021 Drilling Campaign Details Drill Hole Locations and Initial Results for the First 10 holes in the Bekisopa 2021 Drilling Campaign**

No.	BHID	X	Y	AZM_DEG	INC_DEG	Length m	TCR %	From m	To m	Length m	Mineralisation
1	BEKD13	586,904	7,608,150	90	-60	30.30	93	0.00	14.65	14.65	Iron
								14.65	30.30	15.65	Gneiss
2	BEKD14	586,649	7,608,151	90	-60	107.35	97	0.00	61.55	61.55	Gneiss
								61.55	107.35	45.80	Iron
3	BEKD15	586,900	7,607,999	90	-60	30.23	88	0.00	5.63	5.63	Iron
								5.63	30.23	24.60	Gneiss
4	BEKD16	586,799	7,608,001	90	-60	70.30	98	0.00	12.70	12.70	Iron
								12.70	70.30	57.60	Gneiss
5	BEKD17	587,100	7,608,300	90	-60	50.24	95	0.00	5.21	5.21	Iron
								5.21	50.24	45.03	Gneiss
6	BEKD18	587,108	760,450	90	-60	50.24	99	0.00	3.05	3.05	Iron
								3.05	50.24	47.19	Gneiss
7	BEKD19	586,099	7,612,099	90	-60	80.32	98	0.00	35.32	35.32	Iron
								35.32	80.32	45.00	Gneiss
8	BEKD20	586,000	7,612,298	90	-60	80.32	98	0.00	44.67	44.67	Iron
								44.67	80.32	35.65	Gneiss
9	BEKD21	585,903	7,612,500	90	-60	80.30	95	0	80.3	80.3	Gneiss
10	BEKD22	586,349	7,608,100	90	-60	80.24	97	0	80.24	80.24	Gneiss

Drilling in the southern zone confirmed iron mineralisation in all six shallow drill holes completed, BEKD13 to BEKD18.

As expected, the iron mineralisation continues shallowly to the east and more importantly, continues at depth with substantial thickness in the west.

Drillhole BEKD14 positioned west of the 2020 southern drill holes confirmed both the continuation of the iron mineralisation to the west, and that it dips at depth to the west. BEKD14 finished in mineralisation when the drill hole had to be stopped at a depth of 107.35m, as the hand portable EP200 drilling rig could only drill to a maximum of 100-110m as shown in Figure 6.10.



**Figure 6.10: BEKD14 and BEKD13 Drillholes**

BEKD13 confirmed continuation of weathered iron mineralisation from surface, while BEKD14 to the west shows the iron mineralisation to be dipping to the west and the drill was still in mineralisation at the completion of the hole at 107.3m. Total true mineralisation width of plus 250 metres.

Drillholes BEKD19 to BEKD22 are in the northern zone, and on the eastern extent of the expected iron mineralisation zone. Drill holes BEKD19 and BEKD20 intersected iron mineralisation from surface. BEKD21 and BEKD22 did not intersect mineralisation as these tested the eastern extent of the mineralisation and confirmed Akora's interpretation of the mineralisation boundary to the east.

Subsequently a further 42 holes were drilled, for a total 52 holes drilled in 2021 as shown in Table 6.3.

For personal use only

**Table 6.3: Summary of Holes Drilled 2021**

BHID	X	Y	Z	AZM_DEG	INC_DEG	EOH
BEKD13	586,903.63	7,608,149.88	877.32	90	-60	30.30
BEKD14	586,648.63	7,608,150.76	858.32	90	-60	107.35
BEKD15	586,899.34	7,607,998.80	875.91	90	-60	30.23
BEKD16	586,798.39	7,608,000.05	873.45	90	-60	70.30
BEKD17	587,099.85	7,608,299.06	893.48	90	-60	50.24
BEKD18	587,108.14	7,608,450.18	890.82	90	-60	50.24
BEKD19	586,099.14	7,612,099.18	882.88	90	-60	80.32
BEKD20	586,000.74	7,612,298.49	854.23	90	-60	80.32
BEKD21	585,902.65	7,612,499.99	850.93	90	-60	80.30
BEKD22	585,700.20	7,612,700.13	879.09	90	-60	80.24
BEKD23	586,148.66	7,611,899.87	889.56	90	-60	53.35
BEKD24	586,097.83	7,611,899.23	879.24	90	-60	80.37
BEKD25	586,178.20	7,611,700.65	880.68	90	-60	59.32
BEKD26	586,198.31	7,611,701.43	882.07	90	-60	49.26
BEKD27	586,219.48	7,611,700.63	883.35	90	-60	30.32
BEKD28	586,350.17	7,607,799.26	852.28	90	-60	30.27
BEKD29	586,297.24	7,607,799.93	851.50	90	-60	100.32
BEKD30	586,347.56	7,607,900.42	853.18	90	-60	30.22
BEKD31	586,299.38	7,607,899.64	853.07	90	-60	100.28
BEKD32	586,349.59	7,607,998.55	849.42	90	-60	41.22
BEKD33	586,299.32	7,607,999.57	851.44	90	-60	55.28
BEKD34	586,349.02	7,608,100.24	843.08	90	-60	50.24
BEKD35	586,298.71	7,608,099.95	844.15	90	-60	54.26
BEKD36	587,000.46	7,607,599.90	874.57	270	-60	100.34
BEKD37	586,599.83	7,610,599.88	873.35	90	-60	50.24
BEKD38	586,548.34	7,610,600.30	872.09	90	-60	100.32
BEKD39	586,498.23	7,610,798.41	871.69	90	-60	100.34
BEKD40	586,405.93	7,610,800.50	866.33	90	-60	100.27
BEKD41	586,398.01	7,611,000.56	876.79	90	-60	80.28
BEKD42	586,427.88	7,610,999.73	878.77	90	-60	49.27
BEKD43	586,548.19	7,608,150.44	851.91	90	-60	195.61
BEKD43A	586,549.85	7,608,150.38	852.04	90	-60	50.64
BEKD44	586,699.45	7,608,000.52	866.73	90	-60	115.59
BEKD45	586,600.54	7,607,999.66	860.84	90	-60	178.68
BEKD46	586,598.74	7,608,299.97	841.78	90	-60	193.59
BEKD47	586,692.38	7,608,301.29	847.84	90	-60	139.55
BEKD48	586,800.55	7,608,299.73	856.15	90	-60	85.56
BEKD49	586,900.80	7,608,299.76	865.15	90	-60	50.62
BEKD50	585,999.69	7,612,098.60	855.73	90	-60	138.20
BEKD51	585,900.11	7,612,099.53	840.95	90	-60	220.65
BEKD52	585,899.41	7,612,299.50	849.30	90	-60	174.12
BEKD53	585,798.42	7,612,299.90	856.53	90	-60	260.72
BEKD54	586,998.59	7,608,298.84	879.58	90	-60	37.73
BEKD55	586,997.99	7,608,450.87	876.19	90	-60	70.79
BEKD56	586,898.28	7,608,449.63	859.32	90	-60	78.34
BEKD57	586,799.00	7,608,449.57	842.97	90	-60	118.13
BEKD58	586,698.73	7,608,450.91	836.40	90	-60	172.85
BEKD59	586,598.73	7,608,450.07	833.52	90	-60	186.34
BEKD60	586,498.37	7,608,449.31	829.03	90	-60	159.30
BEKD61	586,497.91	7,608,300.24	837.37	90	-60	208.83
BEKD62	586,448.79	7,608,149.27	843.85	90	-60	160.07
BEKD63	586,499.85	7,607,998.66	855.56	90	-60	145.50
<b>Total metres:</b>						<b>5117.02</b>

For personal use only

Akora reported assays for a further nine shallow drillholes namely, BEKD30 to BEKD39 in the Southern Zone, see Figure 6.11 for the location of these drillholes.

All nine drillholes intercepted iron mineralisation from surface, with the highest near surface iron grade of 68.2% Fe in BEKD31 downhole to 8.2m, with the deepest intercepting iron mineralisation to a depth of ~81m downhole in BEKD39.

For personal use only

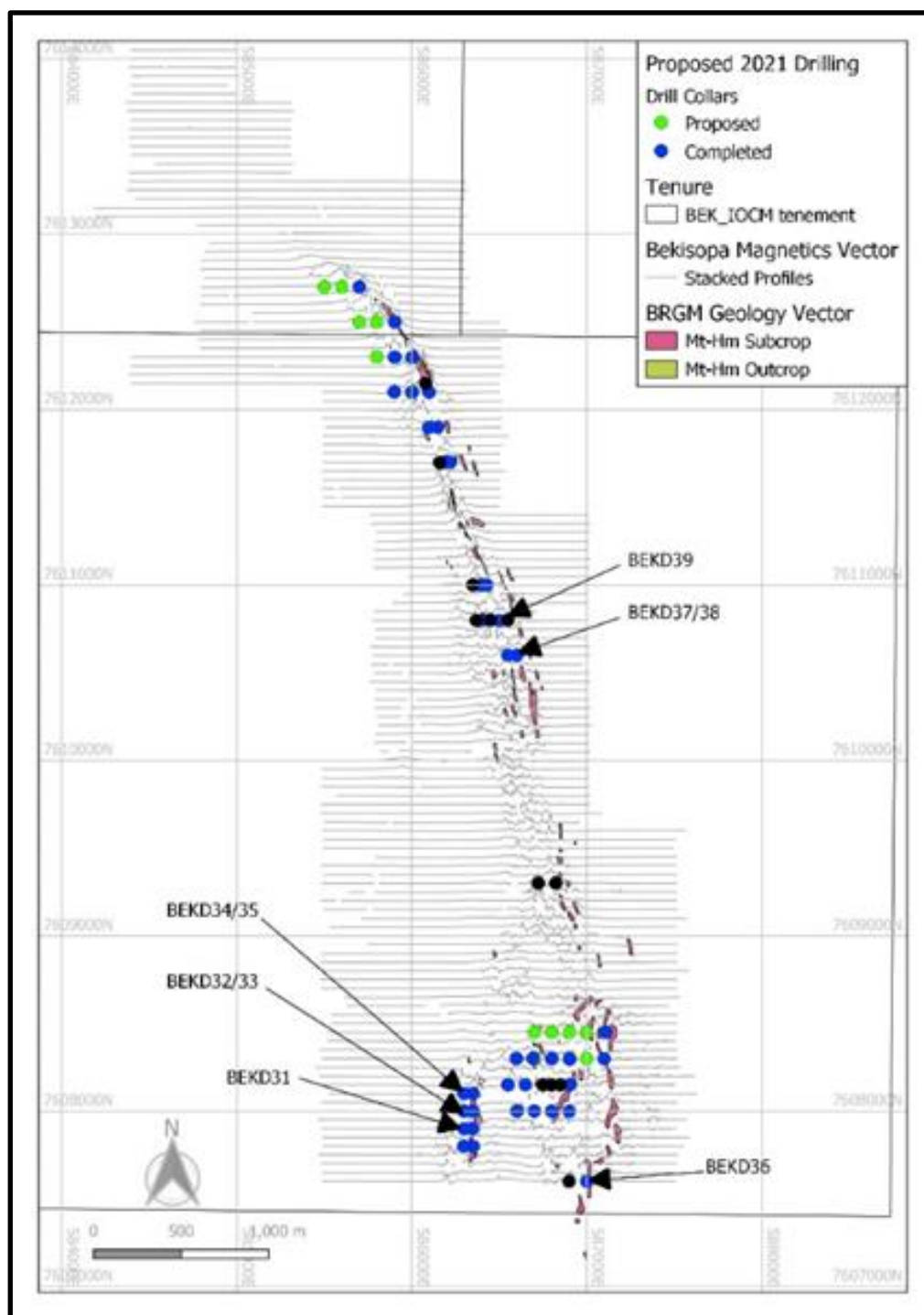


Figure 6.11: Location of 2021 Drillholes, Southern Zone

### 6.3.3 Conclusions of the 2021 Bekisopa Drilling Campaign

The 2021 Bekisopa drilling campaign of 52 holes for a total of 5,117m intercepted iron mineralisation. The drill core shows high-grade iron mineralisation near surface, (regolith-hosted) with extensive high-grade massive iron at depth (bedrock-hosted).

- AKORA completed the 2021 drilling campaign with 5,117m drilled, after accelerating the planned 2022 work programme due to intercepting multiple and extensive iron mineralisation;
- Iron mineralisation was intercepted from 138.25m to 160.75m in BEKD52, and a 115m intercept from 135m to 250m in BEKD53, indicating significant and continuing down dip iron mineralisation;
- The last six drill holes, BEKD58 to BEKD63 in the Southern Zone, suggest significant thicknesses of iron mineralisation at depth, drilling completed at 172.8m, 186.3m and 208.8m in drillholes BEKD58, BEKD59 and BEKD61 respectively;
- Sample preparation and data validation in Madagascar completed by the end of the 2021 with prepared pulp samples transferred from Madagascar (via Europe) to ALS Australia;
- The drilling results included very high-grade weathered massive iron zones at surface, averaging 64-67% Fe, and suggest that this high-grade weathered massive iron mineralisation has the potential for direct ship ore (DSO) with the average head grades better than benchmark 62% Fe, and low impurity levels averaging 2.6% SiO<sub>2</sub>, 2.1% Al<sub>2</sub>O<sub>3</sub>, 0.08% P and 0.03% S.

Examples of these high-grade, low impurity results include;

- BEKD10 - 3.2m at 61.3% Fe;
- BEKD11 - 4.4m at 62.4% Fe;
- BEKD13 - 14.7m at 64.9% Fe;
- BEKD16 - 6.9m at 65.6% Fe; and
- BEKD29 - 6.2m at 66.8% Fe.

Drillhole BEKD029 is shown in Photo 6.2.



Photo 6.2: High-Grade Iron Mineralisation BEKD029

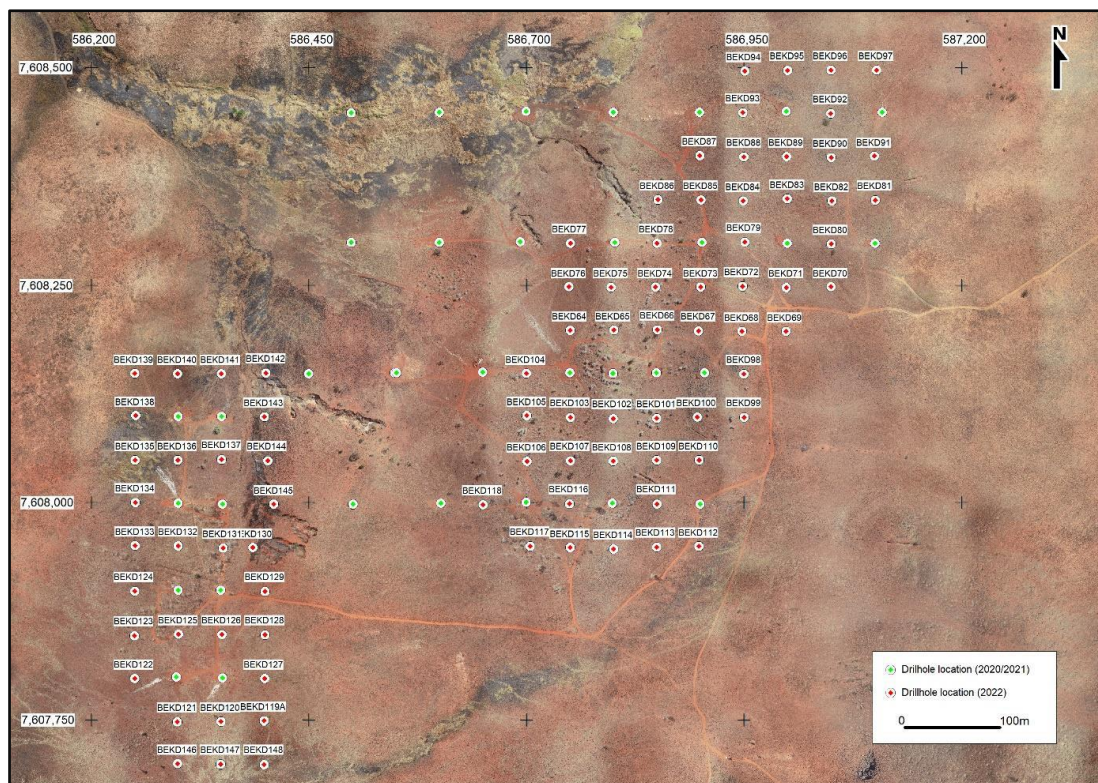
#### 6.3.4 2022 Drilling

The following section is taken mostly verbatim from the “Bekisopa Project Southern Zone Prospect Infill Drilling Report by Vato Consulting”, (March 2023).

Akora completed an infill drilling programme over the Southern Zone between September and October 2022. Drilling focussed on potentially increasing the mineral resources and to better understand the high-grade iron mineralisation and DSO material from surface and within in the regolith (weathered/oxidation zone).

In total, 86 diamond drillholes (BEKD064 to BEKD148) were completed and 1,166.37m drilled (Figure 6.12 and Table 6.4). Drillhole depths varied from 4.69m to 29.60m with an average of 13.56m. A total of 55 drillholes (BEKD064 to BEKD118) were completed on the eastern part and a total of 31 drillholes (BEKD119 to BEKD148) were completed on the western part of the Southern Zone. One drillhole (BEKD119) was re-drilled (BEKD119A) due to poor core recovery in very soft friable formation.

The drilling contractor Croft Drilling Services (“CDS”) completed the diamond drilling programme and a man portable EP200 drilling rig was used. HQ diameter holes and core were produced for all drillholes, except for drillholes BEKD092/BEKD132/BEKD133 where combinations of HQ/NTW diameter holes and core were produced.



**Figure 6.12: Map Showing the Drillhole Locations at Bekisopa South**

### 6.3.4.1 Drilling Results

All of the drillholes intersected iron mineralisation and 72 drillholes intersected higher grades and potential DSO material. Weighted averages for  $Al_2O_3$ , Fe, P, S and  $SiO_2$  were calculated for the iron mineralisation and higher-grade DSO intersections .

The high-grade Fe mineralisation (DSO) occurs over a strike length of approx. 650m with widths between 200m and 350m and open ended to the north, south and west. The DSO in the weathered/oxidation zone (regolith) is associated with predominately massive magnetite-hematite, massive hematite-magnetite and some coarse magnetite-bearing gneiss and ferruginous laterite.

The DSO thicknesses in the regolith varies between 0.36m and 16.15m (average of 5.01m) with weighted averages up to 66.67% Fe.

It appears DSO intersections with weighted averages <60% occur in the more western flat lying areas where the DSO is associated with ferruginous laterite and magnetite-bearing gneiss.

The high-grade Fe mineralisation (DSO) occurs over a strike length of approximately 500m with widths between 50m and 200m and open ended to the north, south and west. The DSO in the weathered/oxidation zone (regolith) is associated with predominately massive magnetite, and some coarse magnetite-bearing gneiss. The thickness of the DSO in the regolith varies between 0.90m and 11.59m (average of 4.34m) with weighted averages up to 66.24% Fe.

For personal use only

Table 6.4: Summary of Holes Drilled 2022						
BHID	X	Y	Z	DEPTH	AZM_DEG	INC_DEG
BEKD064	586749.4	7608199	860.41	10.68	0	-90
BEKD065	586799.7	7608199	862.86	8.63	0	-90
BEKD066	586849.8	7608200	865.83	10.6	0	-90
BEKD067	586897.3	7608198	870.14	19.53	0	-90
BEKD068	586947.1	7608198	875.71	14.62	0	-90
BEKD069	586997.4	7608198	878.21	14.61	0	-90
BEKD070	587049.1	7608249	885.6	8.6	0	-90
BEKD071	586997.8	7608248	877.31	7.58	0	-90
BEKD072	586947.6	7608250	872.52	11.52	0	-90
BEKD073	586899.6	7608249	867.39	12.59	0	-90
BEKD074	586847.5	7608249	863.42	10.6	0	-90
BEKD075	586796.7	7608249	860.25	14.59	0	-90
BEKD076	586748.1	7608249	857.56	8.64	0	-90
BEKD077	586749.8	7608299	853.94	9.66	0	-90
BEKD078	586849.2	7608299	859.29	12.58	0	-90
BEKD079	586950.2	7608301	871.13	14.66	0	-90
BEKD080	587049.6	7608298	889.79	14.58	0	-90
BEKD081	587100.1	7608349	893.79	12.57	0	-90
BEKD082	587050.4	7608348	888.64	17.63	0	-90
BEKD083	586999	7608350	881.72	16.53	0	-90
BEKD084	586948.6	7608348	870.04	20.57	0	-90
BEKD085	586900.1	7608349	863.05	12.61	0	-90
BEKD086	586850.4	7608350	855.69	7.64	0	-90
BEKD087	586898.4	7608400	861.37	22.63	0	-90
BEKD088	586949.3	7608399	868.82	17.6	0	-90
BEKD089	586998.4	7608399	881.04	21.59	0	-90
BEKD090	587049.5	7608398	889.51	19.6	0	-90
BEKD091	587099	7608400	894.45	12.62	0	-90
BEKD092	587048.9	7608448	884.33	24.39	0	-90
BEKD093	586948.2	7608450	868.82	15.61	0	-90
BEKD094	586950.2	7608497	866.9	16.58	0	-90
BEKD095	586999.4	7608498	873.78	29.6	0	-90
BEKD096	587049.4	7608498	878.25	17.51	0	-90
BEKD097	587101.7	7608498	881.9	7.54	0	-90
BEKD098	586949.2	7608149	878.62	10.5	0	-90
BEKD099	586949.4	7608099	878.08	7.58	0	-90
BEKD100	586895.8	7608099	881.79	14.53	0	-90
BEKD101	586849	7608098	874.4	23.57	0	-90
BEKD102	586799.1	7608098	868.2	11.57	0	-90
BEKD103	586749.9	7608099	865.58	14.63	0	-90
BEKD104	586699.2	7608150	860.53	13.65	0	-90
BEKD105	586699.7	7608101	863.03	13.63	0	-90
BEKD106	586700	7608048	865.89	14.63	0	-90
BEKD107	586749.8	7608049	868.32	23.57	0	-90
BEKD108	586798.9	7608048	873.19	24.58	0	-90
BEKD109	586849.1	7608050	881.57	14.57	0	-90
BEKD110	586897.9	7608050	880.44	10.58	0	-90
BEKD111	586849.2	7607999	878.48	11.55	0	-90
BEKD112	586897.6	7607950	872.6	10.57	0	-90
BEKD113	586848.9	7607949	873.32	11.57	0	-90
BEKD114	586799.6	7607948	872.1	11.6	0	-90
BEKD115	586749.7	7607949	867.58	20.65	0	-90
BEKD116	586749	7607999	868.99	25.63	0	-90
BEKD117	586703.7	7607951	865.78	19.61	0	-90

**Table 6.4: Summary of Holes Drilled 2022**

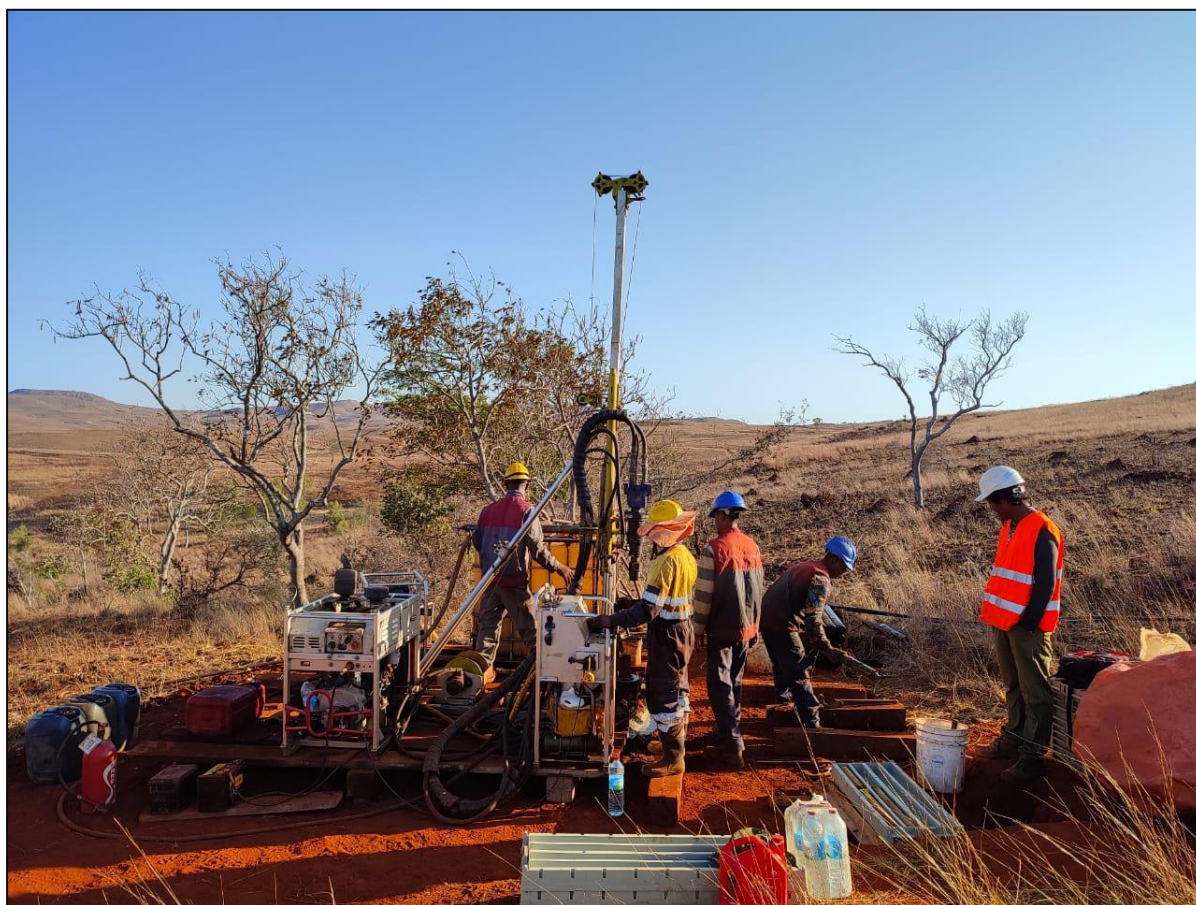
BEKD118	586649.5	7607998	863.67	12.62	0	-90
BEKD119	586397.8	7607749	852.21	11.61	0	-90
BEKD119A	586397.8	7607750	852.21	5.61	0	-90
BEKD120	586348.2	7607749	851.13	9.63	0	-90
BEKD121	586297.9	7607748	850.6	14.6	0	-90
BEKD122	586249.1	7607798	850.21	13.65	0	-90
BEKD123	586248.7	7607848	850.89	8.63	0	-90
BEKD124	586249.2	7607899	851.8	14.65	0	-90
BEKD125	586299.4	7607849	852.25	9.63	0	-90
BEKD126	586349.4	7607849	852.9	11.61	0	-90
BEKD127	586398.5	7607799	853.25	12.66	0	-90
BEKD128	586398.9	7607849	853.75	15.6	0	-90
BEKD129	586399	7607899	853.3	11.62	0	-90
BEKD130	586385	7607949	850.79	13.64	0	-90
BEKD131	586350.7	7607948	852.13	18.62	0	-90
BEKD132	586299.1	7607951	852.93	24.4	0	-90
BEKD133	586249.6	7607951	851.91	15.47	0	-90
BEKD134	586250	7608001	848.7	13.6	0	-90
BEKD135	586249.7	7608050	845.96	9.59	0	-90
BEKD136	586298.7	7608050	847.06	11.63	0	-90
BEKD137	586349	7608050	848.22	9.59	0	-90
BEKD138	586250.3	7608101	845.79	11.58	0	-90
BEKD139	586249.2	7608149	845.81	11.6	0	-90
BEKD140	586298.5	7608149	842.96	9.52	0	-90
BEKD141	586348.6	7608149	839.21	8.58	0	-90
BEKD142	586400	7608150	838.85	7.67	0	-90
BEKD143	586398.1	7608100	842.12	7.59	0	-90
BEKD144	586402.2	7608049	845.25	4.69	0	-90
BEKD145	586409.1	7607999	848.13	5.69	0	-90
BEKD146	586298.4	7607700	848.58	8.65	0	-90
BEKD147	586348	7607700	849.67	6.59	0	-90
BEKD148	586397.7	7607699	851.13	9.69	0	-90
<b>Total metres:</b>						<b>1166.37</b>

For personal use only

## 7 DRILLING

### 7.1 Summary

Drilling by Akora has been exclusively diamond core drilling with a database covering from initial drilling in 2020 to infill drilling at Bekisopa South in 2022. Holes were generally drilled toward the east in 2020 and 2021, with vertical shallow (<30m) drillholes during 2022 targeting DSO material. Drilling contractor CDS completed the diamond drilling programmes in 2020-2022 with a man portable EP200 drilling rig (Figure 7.1) for drill holes less than 100m in length, and a MP500 drilling rig for drill holes greater than 100m in length.



**Figure 7.1: EP200 Drilling Rig used for the 2022 Infill Drilling**

Table 7.1 summarises all drilling conducted at Bekisopa and at Bekisopa South. Exploratory drilling in 2020 was spread throughout the Northern (six drillholes), Central (two drillholes), and Southern Zones (4 drillholes) of the deposit with a variable drill spacing to cover the entire deposit (from 50m up to 500m).

Drilling in 2021 followed up on results from 2020 which also included drillholes in the Northern (13 drillholes), Central (six drillholes), and Southern Zones (33 drillholes). Drilling in 2021 had a spacing of 200m x 100m in the Northern Zone and 200m x 50m in the Central Zone. Drilling in the Southern zone was split into East and West with a 150m x 50m spacing and 100m x 50m spacing respectively.

All 86 drillholes from 2022 were planned as infill drilling in the Southern Zone to target DSO. Drill spacing was variable based on a grid of 50m x 50m or 100m by 50m. Drillhole lengths are generally longer from 2020 and 2021 than in 2022 with a maximum length of 100.43m in 2020, 260.72m in 2021, and 29.6m in 2022. Average drillhole lengths from these periods are 91.29m, 98.40m, and 13.56m for 2020, 2021, and 2022 respectively.

**Table 7.1: Composition of Exploration Database**

Contractor	Year	Type	No. of Holes	Total Metres Drilled (m)	No. of Drill Samples	Comments
Croft Drilling Services	2020	Diamond	12 (4)	1,095.52 (401.75)	1,150 (420)	
Croft Drilling Services	2021	Diamond	52 (33)	5,117.02 (3,248.81)	5,976 (3,748)	1 redrill
Croft Drilling Services	2022	Diamond	86	1,166.37	1,335	1 redrill
<b>TOTAL</b>			<b>150 (123)</b>	<b>7,378.91 (4,816.93)</b>	<b>8,461 (5,503)</b>	
Notes: Values in brackets are values from the Southern Zone. Total Number of samples includes pXRF readings						

## 7.2 Types of Drilling

All drillholes across Akora's drilling campaigns have been diamond core drilling using a man-portable rig. Drill rigs used include the EP200 and MP500 with SINO core medium and soft drill bits and standard tubing. Madagascar has limited exploration drilling equipment and contractors, thus a suitable alternative to diamond core has not been found or utilised. It also noteworthy that the site has poor access and undulating terrain that is not well suited for larger rigs, which also require additional drill pad preparation.

## 7.3 Drilling Setup and Hole Completion

Drill rig setup and hole completion procedures have been set out in an S.O.P produced by Vato Consulting and Akora, and this has been adhered to by the supervising geologist on site. Drilling set up includes:

- Placing of the drill collar by handheld Garmin GPS and marking out the position with a steel/wooden peg.
- Measurement of the drill inclination after the drill has set up, through the use of a Brunton compass.
- Taking a GPS reading at the collar location to determine the bearing (chosen method due to magnetic host rock interfering with the compass).

Holes were completed when the target depth was reached or when the supervising geologist deemed it necessary to terminate the hole. During Infill drilling in 2022, drillholes were terminated at the base of the regolith.

## 7.4 Drilling Methodology and Core Handling

All drilling from 2020 to 2022 at Bekisopa has been diamond core drilling. Drillhole diameter was generally HQ (inner diameter 63.5mm) or NTW (inner diameter 56.1mm). Holes were generally collared at HQ and completed in NTW. During 2020, drillholes were collared using HQ diameter and changed to NTW between 10m and 27m down hole. During 2021, drillholes were collared using HQ diameter and changed to NTW between 3m and 25m down hole.

During 2020 and 2021, drilling was angled at 60° to the East except for BEKD001 (vertical) and BEKD036 (60° to the West). All 2022 drilling was vertical with all holes drilled at HQ diameter, except for BEKD092 and BEKD132 which were drilled with a combination of HQ and NTW, in addition to BEKD133 which was drilled at NTW diameter only. The core barrel length was maintained at 1.5m length in weak/weathered zones and switched to 3m where appropriate.

Once drilled, core is transferred from the drill directly to a core box where the supervising geologist inspected the core. Core boxes include details on Drillhole ID, box number, and From – To depth. The supervising geologist fitted the core together from each drill run and performed logging and photography of the core, also ensuring that core blocks were present and clearly marked with details of depth. The depth measurement was verified by the geologist after recovery had been measured.

No core is left at the drill rig between shifts and all core is transferred to the field camp. At the end of each hole, the collar was surveyed with a handheld Garmin GPS and the hole was closed with a concrete block which details hole number, final depth, and date completed. Drill collars were also surveyed by DGPS (sub-cm accuracy) by the surveying consultant FuturMap (Figure 7.2). The topography was surveyed by Phantom 4 Pro type drones and a pair of LEICA system 1200 dual frequency GPS. Additionally, six reference points (beacons) were established by FUTURMAP with dual-frequency GPS. Each point was monitored for a minimum of 30 minutes to establish an accurate location. These beacons were used by geologists in the field to calibrate their handheld GPS units for greater accuracy.

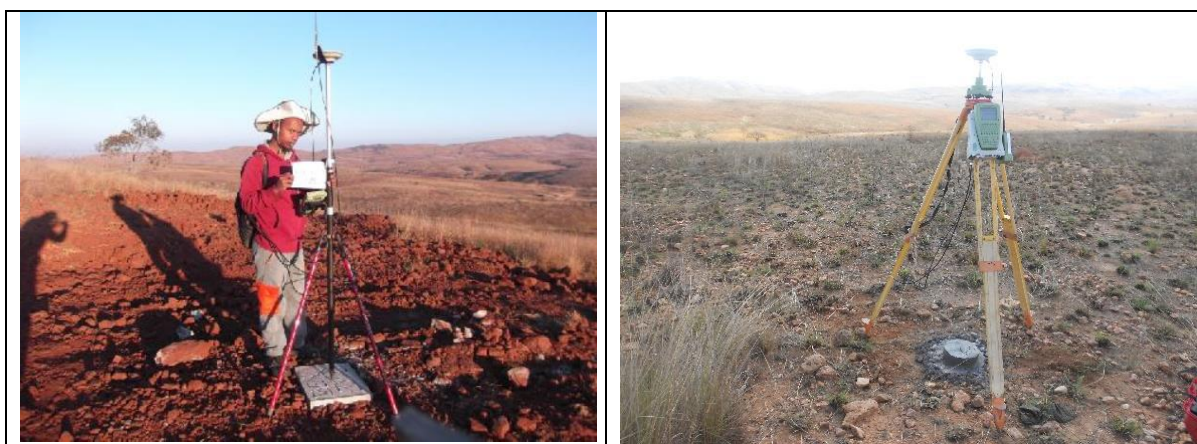


Figure 7.2: DGPS Survey of Drill Collars.

## 7.5 Downhole Surveys

Downhole surveys were conducted by the drill contractor with assistance from the supervising geologist. During 2020, BEKD001-BEKD003 were not surveyed. However, holes BEKD004 to BEKD012 surveys were completed with REFLEX (EZ-Gyro), whilst BEKD013 to BEKD063 surveys were completed done with AXIS (Champ Navigator Gyro) every 10m. All 2021 drillholes were surveyed at intervals of 10m using the Reflex EZ-Gyro gyroscopic multishot camera.

Drillholes completed in the 2022 infill drilling programme were not surveyed as all holes were less than 30m in length and vertical.

## 7.6 Core Orientation

Drill core was not orientated.

## 7.7 Core Recovery

The supervising geologist was responsible for recording Total Core Recovery (TCR) and Rock Quality Designation (RQD) during drilling. Recovery was recorded from each drill run and measured before final depth markers were logged to identify any discrepancies in core blocks.

WAI was provided with a Microsoft Excel spreadsheet containing data from 2020-2022 drilling campaigns recording:

- Sample from and to positions;
- Recovered sample length;
- TCR; and
- RQD.

The spreadsheet contained data from drillholes completed since 2020. Within the spreadsheet are minor instances of obvious error including negative figures due to typographical errors (limited to BEKD113) and measurements of no recovery due to errors in the formula (limited to BEKD012). Negative values were removed from the dataset before review by WAI, whereas the errors in the spreadsheet formula were corrected.

From an original sample set of 6,089 records, this resulted in a total of 6,081 core recovery values for analysis with a mean value of 97%. Of the 6,081 values, 1,669 entries returned a value of >100%. This includes an entry of >200% in BEKD113 which may indicate typographical errors, or errors in recording depth on core blocks. Without considering these samples the mean recovery of the remaining data is 94%. For drillhole BEKD119 the TCR was consistently less than 85% and this drillhole was subsequently re-drilled by Akora. For the re-drilled drillhole the TCR was more than 85%.

Figure 7.3 shows box-and-whisker plots for total core recovery against logged weathered zones. Recoveries in fresh and slightly weathered zones have a mean value of 97%. As expected, a higher degree of weathering has yielded lower recoveries with drill intervals logged as completely weathered having a mean recovery value of 90%. Figure 7.4 compares box-and-whisker plots for total core recovery for each of the drilling programmes. Drilling in 2022 has the lowest mean recovery (93%) of the drill programmes and due to the drilling targeting DSO mineralisation within the regolith.

Figure 7.5 shows a HexBin plot of Fe(%) plotted against total core recovery to identify any potential bias between recovery and grade. There are a small number of high-grade samples with low recovery however no overall bias is observed between recovery and grade. The analysis shown in Figure 7.3 to Figure 7.5 was completed on the dataset with negative values and recoveries of >100% removed.

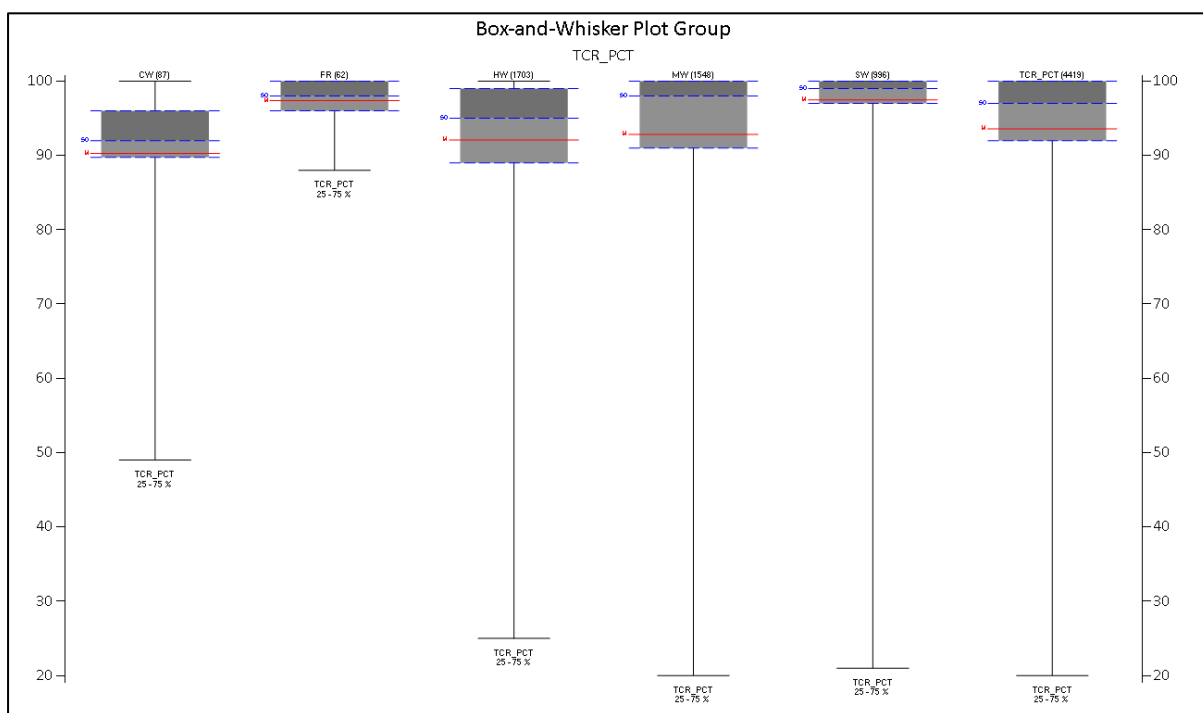
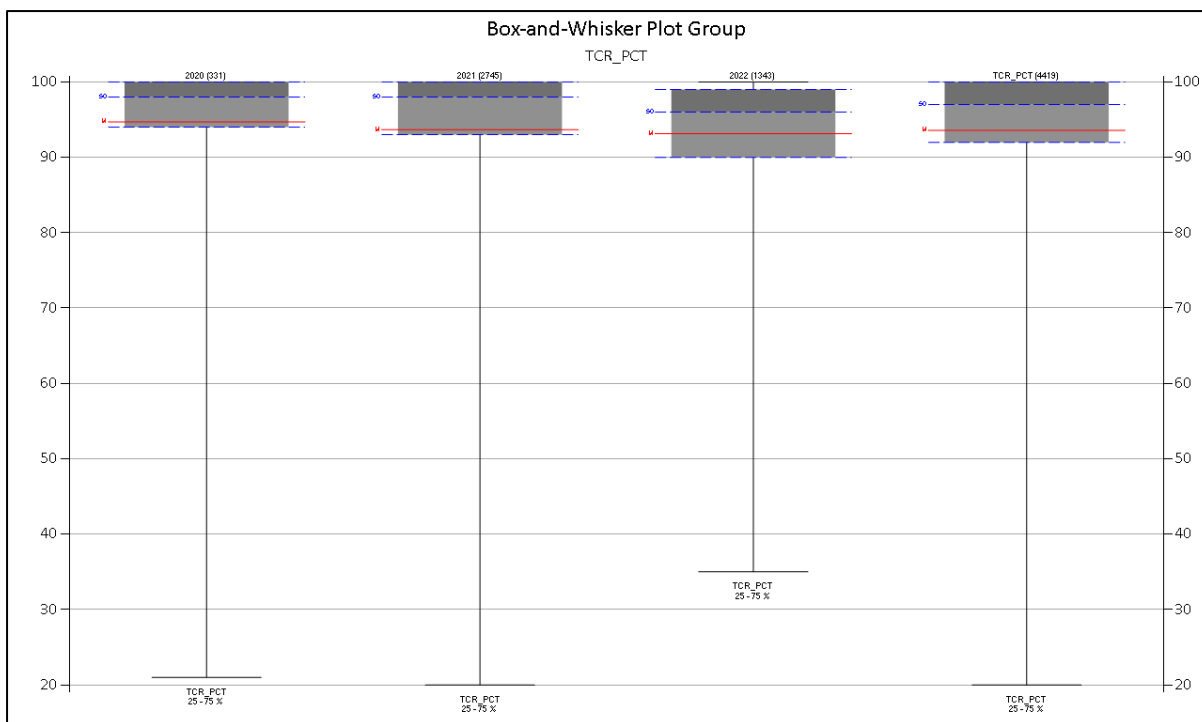
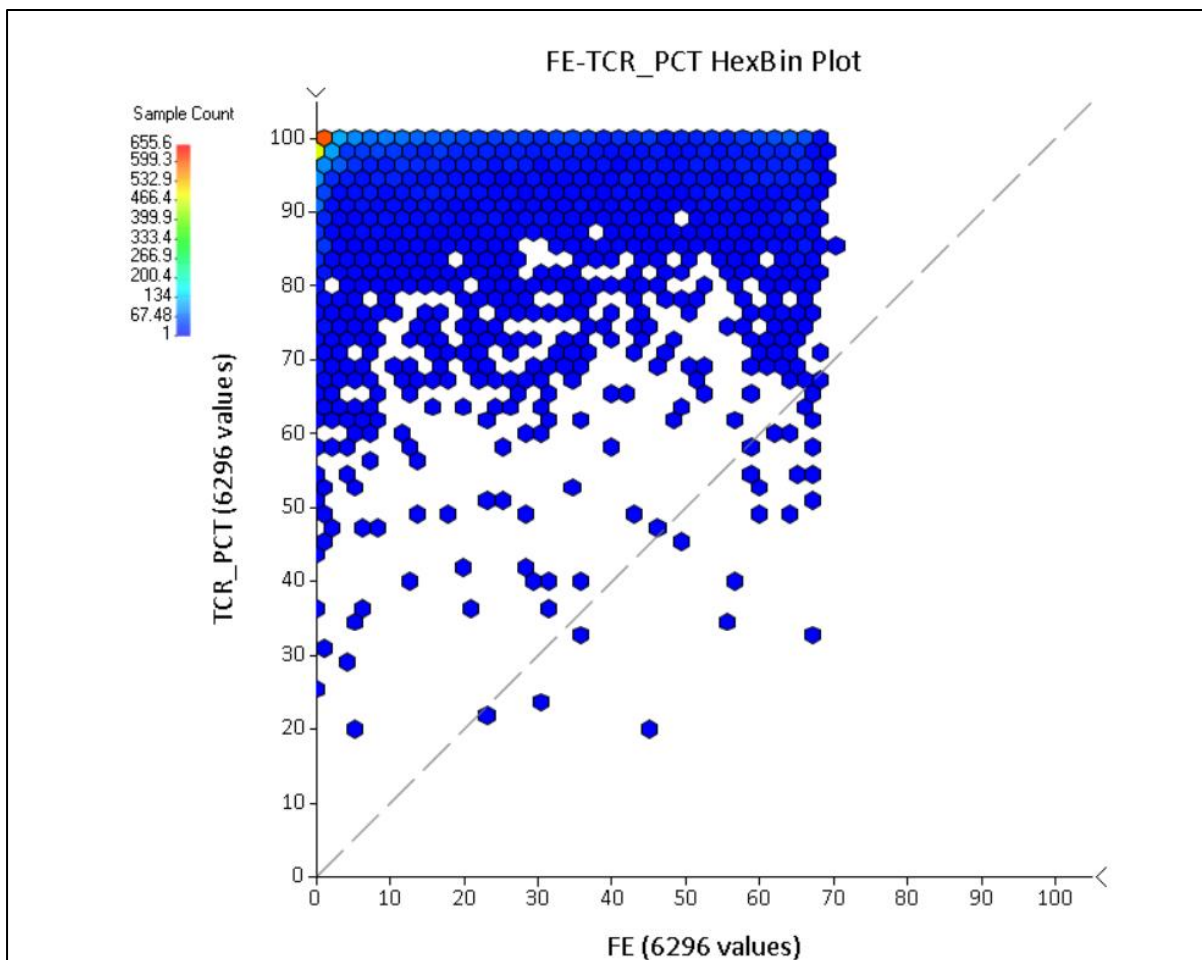


Figure 7.3: Box-and-Whisker Plot Showing Recoveries Against Logging of Weathering.

For personal use only



**Figure 7.4: Box-and-Whisker Plot Showing Recoveries For Each Drill Programme**



**Figure 7.5: HexBin Plot Showing Fe (%) Grades Plotted Against Recovery Values**

For personal use only

## 7.8 Core logging

All drill core was logged qualitatively and quantitatively on site. Logging data was initially recorded on hard copy logging sheets at site (Figure 7.6) and then transferred to an electronic Microsoft Excel database, which is divided into collar, lithology, assay, geotechnical, magnetic susceptibility, and density spreadsheets. Logging parameters have been set up in S.O.P by Akora and Vato consulting, the latter of whom supervised all drilling campaigns. Predefined codes have been utilised where possible to allow for consistency in logging between geologists. Logging parameters include:

- Core Recovery (TCR and RQD)
- Primary Lithology
- Secondary Lithology
- Weathering
- Colour (determined by Munsell colour chart)
- Grain size
- Texture
- Mineralisation type (hematite or magnetite), style, and percentage
- Structure
- Magnetic susceptibility

Metre marking was completed once the geologist had reconciled any core losses or gains in recovery. Secondary lithology logging was only used in regolith to improve data resolution in these zones. Drill core was not orientated, and so only significant structures were recorded such as faults and shear zones. Only the alpha angles of these structures were recorded.

Magnetic susceptibility was recorded at intervals of 25cm down hole to assist in accurate distinction of magnetite and hematite rich mineralisation. Data was recorded with a ZH-SM30 magnetic susceptibility meter for all drillholes and then input into an electronic database.

CollarID: BEKD132 CollarType: DRILL HOLE LoggedBy: AT. Date: 20221016 Page: 1 of 3

Depth_m	TCR	RQD	Lith	SubLith	Weath	ColCode	ColMode	ColDesc	GrainSize	Texture	MinType	MinStyle	MinPct	Structure	MagSusp	Notes	SampleID	
0																		
1	1.59	1.11	REG	SR	HW	25YR 3/4	M	Rd.Bk	0.5 1mm	VAR	MAG	DIS	10-20	572 691	SR of M&NE	R3735	1.00	
1.59																	R3736	
2	0.85	0.82																2.05
2.59			REG	SR	HW	5YR 3/3	D	Gy.Bk Rd	0.5 2mm	VAR	MAG	DIS LUM	20-35	803 71000	SR of M&NE	R3737	3.06	
2.59																	R3738	Core Loss
3	0.93	0.77																3.06
3.59																		4.16
4	0.98	0.50																4.16
4.59																		4.82
5	0.91	0.84	REG	SR	HW	5YR 3/4	D	Rd.Bk Gy	0.5 2cm	VAR	MAG	LUM DIS	20-40	991 71000	SR of M&NE	R3741	5.59	
5.59																		6.40
6	0.95	0.30																6.40
6.59																		7.27
7	1.03	0.74																7.27
7.59																		8.14
8	0.91	0.70	REG	SR	HW	10YR 4/1	D	Gy.Bk Br	0.5 +1cm	VAR	MAG	MAS LUM DIS	30-50	>1000	SR of M&NE + MAG	R3744	8.14	
8.59																		R3745
9																		

Figure 7.6: Logging Sheet for Drill Hole BEKD132.

### 7.9 Core Photography

All drill core from 2020-2022 has been photographed using a digital camera with a resolution of at least 5 Megapixels. Photographs are taken both before and after sampling, in addition to wet and dry conditions. Annotations of Drillhole ID, Box No., and From-To depths are included within photographs to serve as a visual record of logging (Figure 7.7 and Figure 7.8).

For personal use only



Figure 7.7: Photograph of Dry Core From BEKD132 Before Sampling.

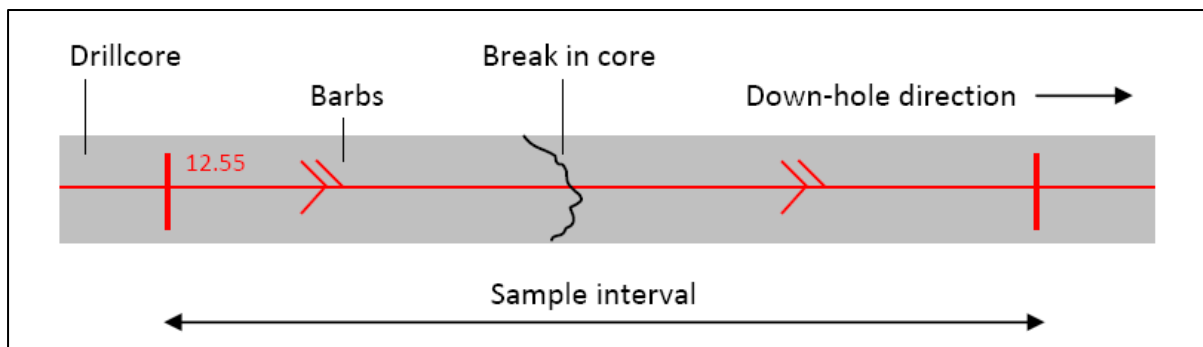


Figure 7.8: Photograph of Wet Half Core From BEKD132 After Being Sampled.

### 7.10 Sampling Methodology

All drill core is sampled at nominal lengths of 1m, however, samples vary in length to account for lithological or mineralisation boundaries. Other factors that determine sample length include changes in rock strength that may reflect a change in weathering, alteration, or faulting etc.

Once the core has been fitted together in the core box it is orientated such that the cut line can be marked perpendicular to the main bedding/foliation dip and marked continuously down the core axis. To minimise any bias in sampling, the cut line is marked through the trough of mineralisation structures.



**Figure 7.9: Illustration Showing Sampling Method (Source: Vato Consulting)**

Sampling consists of half sawn core with intervals ranging from 0.3m to 2.89m in length with an average length of 0.87m. Regolith core is split with a chisel and hammer which is cleaned between sampling, whereas competent/fresh rock core is split using a core cutting saw. Half core samples are placed into polyethene bags along with a paper sample tag which is sealed and placed into a second polyethene bag with a copy of the sample ticket, ready for transfer to the preparation lab.

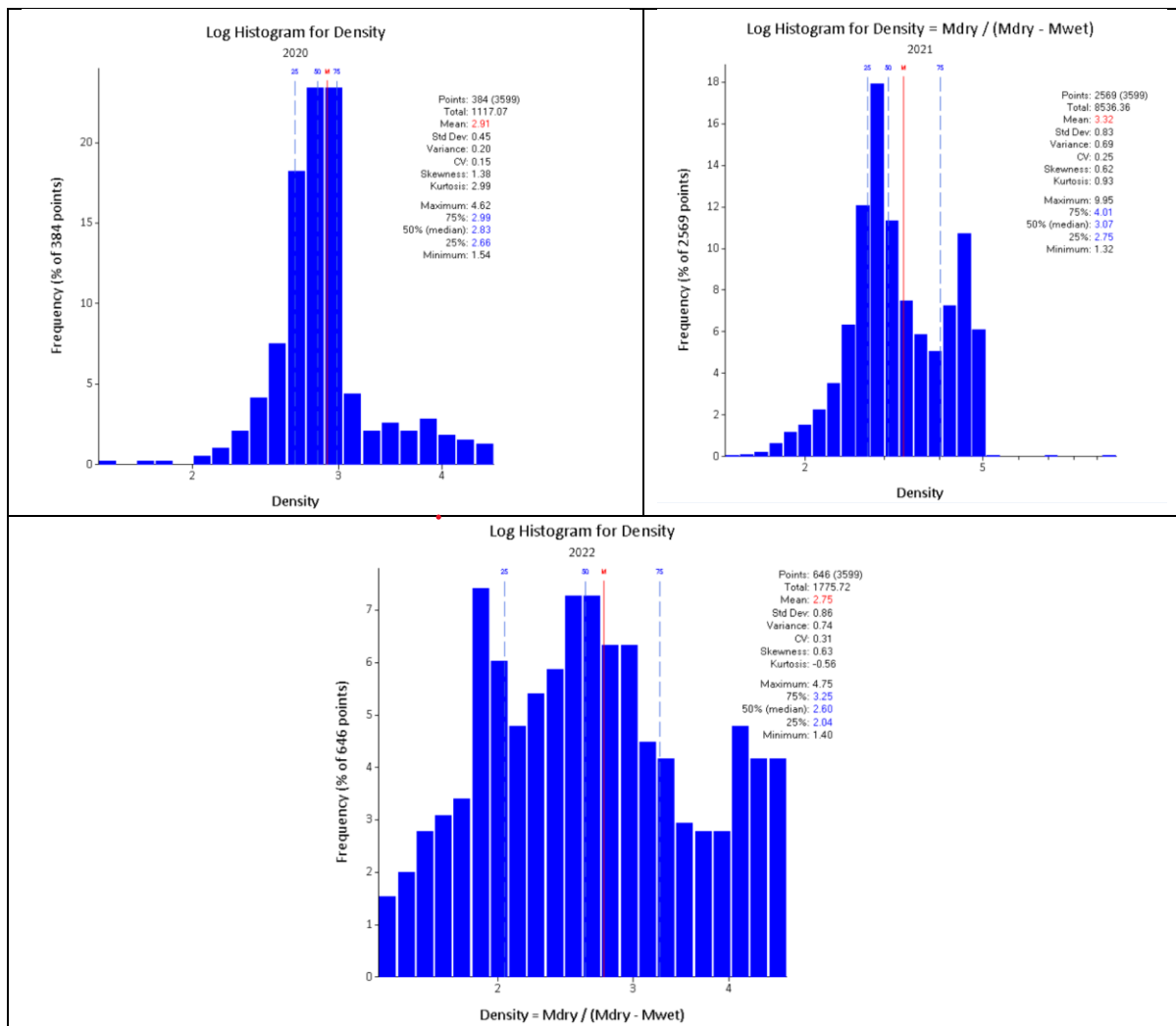
### 7.11 Density Measurements

Density measurements were taken on selected lengths of core at intervals of 10cm-15cm. Density of core is measured prior to sampling by using density scales or using the calliper vernier method in regolith. Competent/hard rock was allowed to dry before its mass was measured on digital scales. The core was then submerged, and the mass was recorded again. The density was subsequently calculated in the formula:

$$\text{Density} = \text{Dry mass} / (\text{Dry Mass} - \text{Wet Mass}).$$

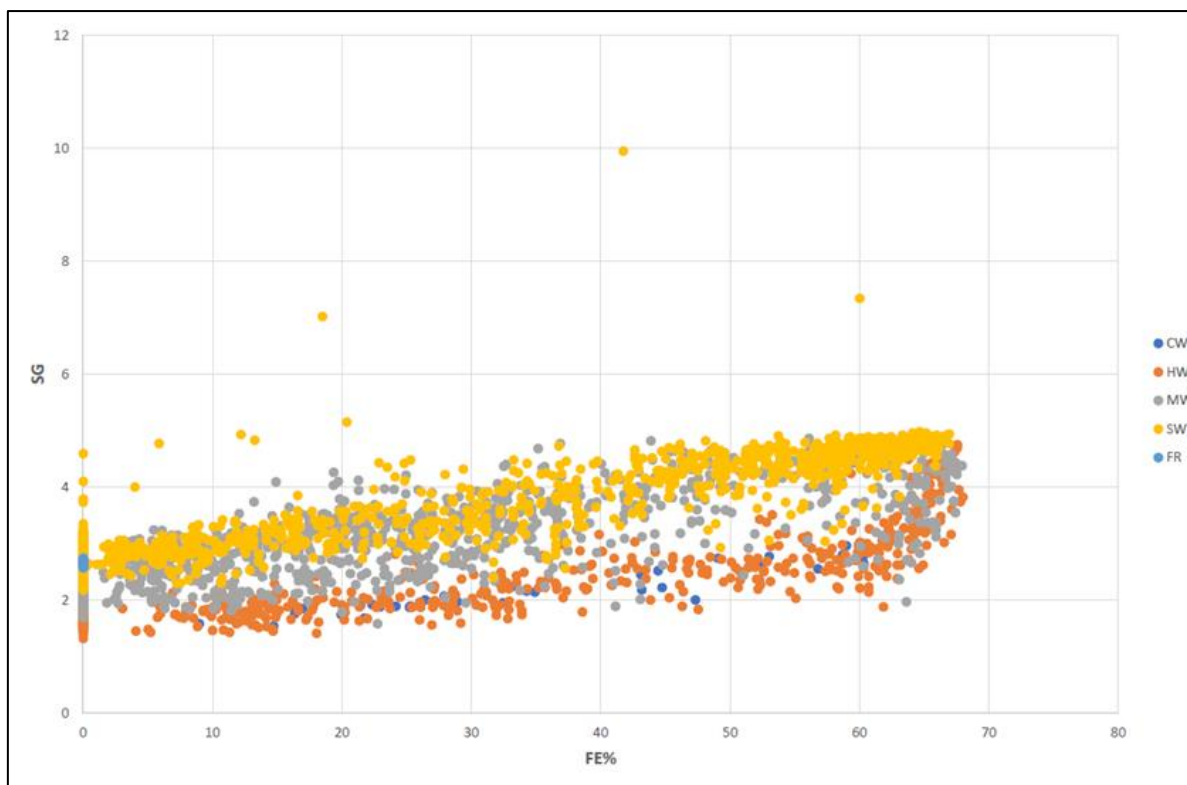
All core pieces comprising each density sample were weighed. Regolith/weathered core samples were allowed to dry before being weighed and measured by the calliper vernier method. The calliper vernier was used to measure the core diameter at several points along the length of the core to estimate an average diameter. Density was subsequently calculated by Mass/Volume.

Density measurements at Bekisopa from 2020 to 2022 consist of 2,717 density scale measurements and 3,453 calliper method measurements creating a total of 6,170 density measurements. Of the 6,170 measurements, 1,448 density scale measurements and 2,151 calliper method measurements, totalling at 3,599 density measurements, are from Bekisopa South samples. Figure 7.10 shows all density data available for Bekisopa South, split by drill programme.



**Figure 7.10: Density Results from Core Samples at Bekisopa South Split by Year Drilled**

Figure 7.11 shows a scatter plot between density and Fe (%), colour coded by weathering type. A clear positive correlation between Fe grade and density is observed with different density populations based on mineralisation and weathering. WAI has therefore elected to use regression analysis between Fe grade and density within each mineralisation and weathering sub-domain for the purposes of Mineral Resource estimation and this is detailed in Section 11.8.



**Figure 7.11: Scatter plot Showing Fe Grade Against Density Measurements**

**Colour coded by weathering type. CW is completely weathered, HW is highly weathered, MW is moderately weathered, SW is slightly weathered, and FR is fresh rock.**

### 7.12 Drillhole Orientation Relative to Mineralisation

Mineralisation is interpreted to be north-south trending and westerly dipping in the Southern Zone. Therefore, the majority of drillholes are orientated to the east, perpendicular to interpreted mineralisation, and aim to intersect true thickness of mineralised zones. The DSO mineralisation is controlled by the base of the regolith and interpreted to be relatively horizontal and tabular in geometry. Infill drilling in 2022 was positioned vertically to target the DSO mineralisation. No sampling bias has been observed with respect to drillhole orientation.

### 7.13 Summary

All exploration drilling from 2020 to 2022 covering the Bekisopa Iron Project is exclusively diamond drilling with core diameters from HQ to NTW. Drillholes at Bekisopa South from 2020 to 2021 dominantly dip to the east to attempt to intersect the interpreted trend of mineralisation as close to perpendicular as possible, with one drill hole dipping west. Drilling in 2022 consisted of infill drilling at Bekisopa South targeting DSO mineralisation, all of which are vertical and shallow (<30m depth). Most of the DSO mineralisation is intersected on a grid spacing of 50m x 50m, with the majority of deeper mineralisation intersected on a grid spacing of 100m x 150m.

All core is qualitatively logged with all significant geological information captured. XRF readings were taken on mineralised sections of core with magnetic susceptibility readings taken every 25cm down hole. Total Core Recovery and Rock Quality Designation is measured on all drillholes as part of geotechnical logging. Average Core Recovery is 94%, with slightly lower recoveries in highly weathered zones. Core recovery for drilling at Bekisopa South is good with no relationship to Fe grade.

Sampling of diamond core is nominally 1m half core lengths truncated by significant geological contacts. Average sample length is 0.87m. The entire core length was sampled but only identified mineralisation was sent off for analysis at an accredited laboratory.

Density of core was measured using either the Archimedes method on competent sections of core, or by Calliper Vernier method of weathered core. There is a positive correlation observed between Fe grade and density based on each mineralisation and weathering sub-domain.

## 8 SAMPLE PREPARATION, ANALYSIS AND SECURITY

### 8.1 Laboratories Used

All preparation of exploration samples has been undertaken at The Office of National Mining and Strategic Industries (OMNIS) preparation lab in Antananarivo, Madagascar. OMNIS are in the process of accrediting the preparation laboratory to ISO/IEC 17025:2017.

The primary laboratory for analysis of samples was due to be ALS Iron Ore Technical Centre in Perth however, in 2020 ALS in Galway, Ireland was used due to exporting and importing issues during the Covid-19 Pandemic. ALS in Perth was used thereafter in 2021 and 2022. Both laboratories are accredited ISO/IEC 17025:2017. Before analysis at ALS Ireland, samples underwent additional preparation of pulverising.

### 8.2 Sample Preparation and Splitting

#### 8.2.1 OMNIS Sample Preparation Procedure

Half core samples were delivered to OMNIS in secure double plastic bags which were weighed upon reception. Samples were oven dried at 110°C-120°C until totally dry. Samples were then re-weighed after drying and crushed to 2mm through a jaw crusher. The dry samples were split twice through a riffle splitter (1:1) to produce a quarter sample. Of the homogenised material, 100g was collected using a plastic scoop and bagged for Davis Tube Recovery Test work (“DTT”). Sub samples of 100g with 80% passing 2mm were pulverised to 85% passing minus 75 microns for subsequent analysis.

Sample numbers were written onto the kraft sample envelope with permanent marker pen, and the original sample ticket was also placed into the envelope. After each sample the equipment was cleaned with a brush or compressed air to minimise contamination. The remaining reject material was retained, numbered as per SampleID's and stored at the sample preparation facility.

#### 8.2.2 ALS Ireland Sample Preparation Procedure

Samples received at ALS in Ireland were weighed upon reception and pulverised until 250g with 85% passing 75 microns was collected. Samples then underwent a pulverising QC test before being sent for analysis with each sample recorded with a barcode.

### 8.3 Assaying and Sample Analysis Methodology

#### 8.3.1 ALS Ireland and ALS Perth Sample Analysis

Samples submitted to both ALS Ireland and ALS Perth were analysed by ME-XRF21u (Iron Ore by XRF un-normalised) for total Fe% and OA-GRA05x for Loss on Ignition by TGA Furnace.

Analysis at ALS in Ireland and Perth was part of the “Iron Ore Suite” and consisted of multi element analysis including the major rock forming minerals and a suite of trace elements. This included Fe, Al<sub>2</sub>O<sub>3</sub>, SiO<sub>2</sub>, P, S, K<sub>2</sub>O, MgO, Mn, Ni, Pb, Sn, Sr, TiO<sub>2</sub>, V, Zn, Zr, in addition to a 3-point Loss on Ignition (“LOI”) at 371°C, 650°C, and 1000°C. Iron ore samples were fused with a lithium borate fusion containing an oxidising agent followed by XRF instrument analysis for major rock forming elements and trace element concentrations. Results have been reported ‘un-normalised’.

As part of the “Iron Ore Suite” at ALS, the recovered magnetic fraction of selected samples was analysed using DTT to determine the concentrate grades along with the head grades. WAI has been presented both head assay and concentrate assay data. Only mineralised sections of drill core from 2020-2021 drilling were selected for DTT test work, 2022 drilling did not include DTT test work. Detection limit is reported to be 0.01% Fe with an upper limit of 75% Fe.

### **8.3.2 Akora XRF Analysis**

Akora used an in-house pXRF to assist in quantitative interpretation of mineralised zones on drill core. The Bruker Titan S1 handheld pXRF was used by Akora and was calibrated by the issuer GeoExploration in January 2021. The entire length of drill core was measured for drillholes BEKD001 to BEKD024. After this, readings were completed only where mineralisation was visually identified. The assay database includes pXRF readings for non-mineralised sections of drill holes BEKD001 to BEKD024 but not for subsequent drill holes.

### **8.4 Quality Control**

Akora submitted its own QA/QC samples consisting of blanks, pulp duplicates, and certified reference materials (CRM). Both ALS in Ireland and in Perth submitted internal QA/QC samples consisting of blanks, pulp duplicates and CRMs and these data have made available to Akora. For QA/QC, Akora followed the S.O.P for sampling produced by Vato Consulting. CRM and blank samples were included every 40<sup>th</sup> sample with CRMs submitted starting at the 20<sup>th</sup> sample and blanks submitted starting on the 40<sup>th</sup> sample in the stream. Duplicates were not prepared in the field but at the preparation lab (OMNIS) in Antananarivo. Akora requested two to four duplicate samples to be included per 100 samples.

Akora have also utilised silica chip blanks and two CRMs (OREAS182 and CSM2) during in-house pXRF analysis.

Akora has produced control charts to monitor the performance of quality control samples and identify any errors in sampling. WAI has reviewed these control charts and produced their own analysis of the available QA/QC data from Bekisopa South. Results of this QA/QC analysis is provided in Section 9.

## 8.5 Chain of Custody and Sample Security

Chain of custody is set out in an S.O.P by Vato Consulting and Akora. Typical chain of custody procedures for drill core samples at Bekisopa are as follows:

- After core has been cut by saw (hardrock) or splitter (weathered rock) and photographed, one half is placed into the core tray for reference whereas the other half is transferred to a plastic bag and accompanied with a sample ticket.
- Samples are placed into a second plastic bag containing a copy of the sample ticket.
- Samples are collected in batches and given a batch reference number.
- Prepared samples are accompanied by the batch number, sample submittal form and instruction sheets as required by the relevant laboratory.
- Chain of Custody forms contain the following information:
  - Sample Identification numbers
  - Type of samples
  - Date of sampling
  - List of analyses required.
  - Customs approval
  - Waybill number
  - Name and signature of sampling personnel
  - Transfer of Custody Acknowledgement
- Samples are delivered to the lab by courier. A copy of the chain of custody form is signed and dated and placed in a sealable plastic bag taped into the lid of the sample boxes.
- Each samples batch is accompanied by a chain of custody form.
- Chain of custody forms are kept permanently on site.

The on-site geologist is responsible for the care and security of the samples from sample collection to export stage. Samples prepared during the day are stored in the preparation facility in labelled sealable plastic bags. Chain of custody procedures ensure that the possession of the samples from collection, customs, export, analysis and reporting of results is documented.

H&S noted that there was one case of sample mix up whereby one box of samples was incorrectly sent to ALS Ireland, and one sent to Perth. The lab in Ireland subsequently sent the sample box to Perth where both boxes of samples were analysed. No tampering of either boxes was reported to have been observed.

## 8.6 Summary

Sample preparation for all samples at Bekisopa has been carried out at OMNIS preparation lab in Antananarivo. The laboratory is in the process of accrediting to ISO/IEC 17025:2017 at the time of this report. Preparation of samples included drying, crushed to 2mm, split and then a sub-sample of 100g is pulverised to 85% passing minus 75 microns. At this stage, relevant sub-samples were also taken for DTT analysis. DTT testing was completed in drilling programs 2020 and 2021 but was not part of the 2022 infill drilling programme.

Sample analysis was conducted at ALS laboratories in Ireland and Perth, both of which are accredited to ISO/IEC 17025:2017. Samples collected in 2020 utilised both laboratories whereas samples collected in 2021 and 2022 were sent exclusively to ALS Perth. Analysis consisted of ME-XRF21u (Iron Ore by XRF un-normalised) for total Fe% and OA-GRA05x for LOI by TGA Furnace. This formed part of the “Iron Ore Suite” testing at ALS which also included DTT analysis.

QA/QC protocol used by Akora included blanks, CRMs and pulp duplicate samples submitted by Akora at the sampling stage. CRM and blank samples were included every 40<sup>th</sup> sample with CRMs submitted starting at the 20<sup>th</sup> sample and blanks submitted starting on the 40<sup>th</sup> sample. Pulp duplicate samples were collected during the preparation stage with between two and four duplicate samples submitted per 100 samples. In addition, internal QA/QC samples by ALS were also undertaken. The performance of the QA/QC samples is detailed in Section 9.

For personal use only

## 9 DATA VERIFICATION AND QUALITY CONTROL PROCEDURES

### 9.1 Introduction

Akora's exploration database for the Bekisopa Iron Project contains information from 2014 to 2022, however, for this MRE at Bekisopa South, the relevant data from the exploration database is from 2020 to 2022 and is composed entirely of diamond drilling. This section describes the data verification that has been completed on these data including an analysis of the performance of QA/QC samples. Verification procedures as described below are not exhaustive and a continual, rolling system of checks and verification on newly acquired data will be beneficial moving forward.

### 9.2 Database Verification

WAI carried out a validation of the exploration database and included:

- Verification that collar coordinates coincide with topographical surfaces.
- Ensuring each drill hole collar recorded has a valid XYZ coordinates.
- Ensuring collar coordinates are inside expected limits.
- Ensuring collar coordinates are reported to an expected accuracy.
- Checking for the presence of any duplicate drillhole collar IDs or collars with duplicate collar coordinates.
- Ensuring all holes have valid downhole surveys or at least a recorded start bearing and dip.
- Verification that downhole survey azimuth and inclination values display consistency.
- Checking for the presence of any unusually large changes in dip and/or bearing in downhole survey records that may indicate the presence of typographic errors.
- Check for overlapping sample intervals.
- Check for duplicate sample intervals.
- Identify sample intervals for which grade has been recorded that have excessive length which may indicate composite samples or typographic errors.
- Check minimum and maximum grades to ensure they are within expected limits.
- Assessing for inconsistencies in spelling or coding (typographic and case sensitive errors) of BHID, hole type, lithology etc. to ensure consistency in data review.

WAI has found that the drillhole database is generally error free with minor discrepancies noted such as BHID containing an additional '0' in the drillhole collars when compared to the drillhole surveys. Other errors include possible typographic errors in 'From-To' depths in the 'Geotech Excel File' creating negative and extremely high recovery values.

### 9.3 Collar Survey Verification

During the site visit, WAI carried out a collar coordinate verification exercise using a handheld GPS against preserved collar locations. Table 9.1 shows the results of 18 collar positions visited at Bekisopa South. All locations are within tolerable distances given the potential error in the handheld GPS

coordinates. It should be noted that Akora has three fixed survey beacon point (positioned by the surveyors using a DGPS), from which they calibrate their handheld GPS units for greater accuracy.

Table 9.1: WAI Global Check Comparison of Collar Locations						
Hole ID	Measured		Database		Difference (m)	
	Easting	Northing	Easting	Northing	Easting	Northing
BEKD009	586,750.00	7,608,151.00	586,749.33	7,608,150.00	0.67	1.00
BEKD013	586,905.00	7,608,149.00	586,903.63	7,608,149.88	1.37	-0.88
BEKD014	586,649.00	7,608,151.00	586,648.63	7,608,150.76	0.37	0.24
BEKD016	586,797.00	7,607,999.00	586,798.39	7,608,000.05	-1.39	-1.05
BEKD029	586,297.00	7,607,799.00	586,297.24	7,607,799.93	-0.24	-0.93
BEKD032	586,348.00	7,607,997.00	586,349.59	7,607,998.55	-1.59	-1.55
BEKD033	586,299.00	7,607,998.00	586,299.32	7,607,999.57	-0.32	-1.57
BEKD044	586,698.00	7,608,000.00	586,699.45	7,608,000.52	-1.45	-0.52
BEKD067	586,900.00	7,608,196.00	586,897.25	7,608,198.22	2.75	-2.22
BEKD068	586,947.00	7,608,196.00	586,947.11	7,608,197.78	-0.10	-1.78
BEKD091	587,100.00	7,608,400.00	587,099.03	7,608,399.56	0.97	0.44
BEKD092	587,052.00	7,608,449.00	587,048.94	7,608,448.43	3.06	0.57
BEKD116	586,750.00	7,607,999.00	586,749.00	7,607,999.43	1.00	-0.42
BEKD118	586,649.00	7,607,999.00	586,649.47	7,607,998.24	-0.47	0.76
BEKD121	586,299.00	7,607,747.00	586,297.92	7,607,748.49	1.08	-1.49
BEKD122	586,248.00	7,607,797.00	586,249.09	7,607,798.23	-1.09	-1.23
BEKD131	586,351.00	7,607,948.00	586,350.73	7,607,948.32	0.27	-0.32
BEKD132	586,298.00	7,607,950.00	586,299.08	7,607,950.95	-1.07	-0.95

In addition, Akora conducts their own collar survey verification. At the end of each drillhole, the collar is surveyed with a handheld GPS. Akora employed surveying consultant FuturMap to survey drill collars and topography using a Leica DGPS and a Phantom 4 Pro drone for a topographic survey. WAI reviewed the position of the drill collars against the topographic surface (generated from this survey) and found that the difference between recorded collar elevation and topographic surface was generally less than 1m.

#### 9.4 Down-Hole Survey Verification

WAI is not aware of any programmes of verification of downhole surveys. Drillholes from infill drilling in 2022 are short (<30m) and vertical with little scope for large deviation in either dip or bearing. During import of the exploration data, WAI carried out checks to search for abnormally large changes in dip and dip direction in consecutive downhole surveys of the deeper drillholes, but no issues were identified.

#### 9.5 Topographic Survey Verification

The topographic survey was generated from a survey conducted by FuturMap using a Phantom 4 Pro drone with DPGS ground control points. A sub-cm accuracy is quoted for this survey and although no external verification has been completed on this topographic survey, verified collars match the topography reasonably well.

## 9.6 Density Measurement Verification

WAI is not aware of any programmes of verification of density data. All density measurements are taken by Akora prior to sampling, on selected 10cm-15cm of core.

## 9.7 Quality Control Procedures

### 9.7.1 Introduction

QA/QC is used to verify the validity of sample collection, security, preparation, and analytical methods. The aim of the QA/QC programme is to quantify and monitor any errors, and to provide information that might be used to improve sampling and analytical procedures to minimise any errors. A comprehensive QA/QC programme should monitor the accuracy, precision and contamination of each stage of exploration from the sampling through to the final assay value produced by the laboratory.

QA/QC programmes from 2020-2022 at Bekisopa have incorporated the inclusion of duplicate samples, certified reference materials (CRMs), and blank samples inserted at differing ratios into the sample stream as detailed in Section 8. The QA/QC programmes of the various exploration campaigns have been reviewed separately by WAI to assess any variances over time and are summarised in the sections below.

### 9.7.2 Summary of Available QA/QC Information

Akora has provided a QA/QC dataset covering drilling campaigns from 2020-2022 at Bekisopa. For this review WAI has focussed on samples collected from drilling at Bekisopa South as this is the focus of the MRE contained in this report. A summary of the Akora QA/QC samples for Bekisopa South is provided in Table 9.2.

<b>Table 9.2: Summary of Quality Control Samples by Exploration Programme (Bekisopa South Only)</b>				
<b>Programme</b>	<b>Number of Holes</b>	<b>Hole IDs</b>	<b>Total Length Drilled (m)</b>	<b>Type of Quality Control Data Available</b>
2020	4	BEKD009-BEKD012	401.75	6 CRMs, 4 Duplicates, 6 Blanks
2021	33	BEKD013-BEKD063	3,248.81	96 CRMs, 76 Duplicates, 93 Blanks
2022	86	BEKD064-BEKD148	1,166.37	37 CRMs, 28 Duplicates, 34 Blanks
<b>TOTAL</b>	<b>123</b>		<b>4,816.93</b>	<b>139 CRMs, 108 Duplicates, 133 Blanks</b>

The performance of the QA/QC samples was monitored by Akora during the drilling programmes. This allowed for the identification of potential errors during assaying and for these errors to be addressed by re-assaying of samples within specific sample batches according to the type and severity of the failure. Table 9.3 shows the failure criteria of QA/QC samples set out by Vato Consulting for Akora, and the required actions for sample batches with failures. An example of a failure being addressed by re-assaying and the subsequent results is highlighted in Table 9.4.

Failure condition	Result	Action
An in-house standard fails between mean $\pm$ 1.96 and 3 SD, but no other failure occurs in the batch	Standard is accepted	No action required - batch is accepted
Two in-house standards fail between mean $\pm$ 1.96 and 3 SD	Both standards are classified as failures	Re-analyse up to 5 samples either side of the failed standards
An in-house standard fails beyond mean $\pm$ 3 SD	Standard is classified as a failure	Re-analyse up to 5 samples either side of the failed standard
Both an in-house standard and an in-house blank fail	Both are classified as failures	Re-analyse up to 5 samples either side of the failed standard and failed blank
An in-house blank shows a major failure	Blank is classified as a failure	Inform lab of potential contamination. Re-analyse up to 5 samples either side of the failed blank
An in-house blank shows a minor failure, but no other failure occurs in the batch	Blank is accepted	Inform lab of potential contamination. No action required - batch is accepted
If more than X laboratory repeats or in-house duplicates fail, and no explanation is given by the laboratory	Repeats are accepted	Inform lab of poor repeatability and query homogeneity of prepared sample. No action required - batch is accepted

Source: Vato Consulting

PH026294 (Original Batch)		PH23044317 (Re-assay)	
Sample ID	Fe (%)	Sample ID	Fe (%)
D6087	13.62	D6087	13.26
D6088	15.14	D6088	14.64
D6089	12.02	D6089	11.74
D6090	12.26	D6090	11.98
D6099	66.4	D6099	66.39
<b>D6100 (OREAS 404)</b>	<b>54.44</b>	<b>D6100 (OREAS404)</b>	<b>55.13</b>
D6101	46.11	D6101	45.52
D6102	17.98	D6102	17.7
D6103	23.71	D6103	23.17
D6104	13.56	D6104	13.11
D6105	6.89	D6105	6.7

ALS Perth and ALS Ireland have also inserted internal QA/QC samples during their analysis, which consisted of CRMs, blanks and duplicates. These data were made available to Akora who conducted a review using control charts and has also been provided to WAI for review.

### 9.7.3 Analysis

For CRMs and blank samples, control charts such as Shewhart X (average) and R (range) charts are constructed for each element standard. The control charts plot process variability, with metal content on the Y-axis and sample number on the X-axis. The plotting of data on charts of this type allows for the easy recognition of samples that fall outside of the action limits applicable for each standard used.

For CRM samples, warning and control limits are established at mean  $\pm 2$  and  $\pm 3$  standard deviation limits respectively. Any analysis beyond the  $\pm 3$  standard deviation limit is considered as a failure. For blank samples, failures were determined based on  $\pm 5$  times the assay detection limit with significant failures determined based on  $\pm 10$  times the assay detection limit.

For duplicate sample sets, levels of precision were reviewed by WAI using the following statistical measures:

- **Summary Statistics** showing the mean, mode, standard error, range and standard deviation can be indicators if the data sets agree.
- **Rank HARD Plot** which is the ranked half absolute relative difference, ranks all assay pairs in terms of precision levels measured as half of the absolute relative difference from the mean of the assay pairs (HARD), used to visualise relative precision levels (typically 90%) and to determine the percentage of the assay pairs population occurring at a certain precision level (10%). It should be noted that as the HARD statistic uses an absolute difference, a ranked HARD plot does not reveal bias in duplicate data, only the relative magnitude of differences (i.e. precision). The HARD values are sorted from lowest to highest and ranked accordingly, with the rank expressed as a percentage. The ranked HARD plot is then generated by plotting the percent rank on the X-axis against the HARD value on the Y-axis. A rank HARD plot is constructed that enables quick identification of the percentage of the sample pairs with a HARD value less than 10%.
- **Correlation Plot** is a simple plot of the value of the duplicate samples, assay 1 against assay 2. This plot allows an overall visualisation of precision and bias over selected grade ranges. Correlation coefficients are also good indicators to quantify the agreement between data sets. A correlation greater than 0.9 is generally described as strong, whereas a correlation less than 0.6 is generally described as weak.
- **Thompson and Howarth Plot** showing the mean relative percentage error of grouped assay pairs across the entire grade range, used to visualise precision levels by comparing against given control lines.
- **Mean vs. HARD Plot** used as another way of illustrating relative precision levels by showing the range of HARD over the grade range.
- **Mean vs. HRD Plot** is similar to the above, but the sign is retained, thus allowing negative or positive differences to be computed. This plot gives an overall impression of precision and shows whether there is significant bias between the assay pairs by illustrating the mean percent half relative difference between the assay pairs (mean HRD).

The various types of quality control samples are reviewed in the sections below.

## 9.7.4 Certified Reference Materials

### 9.7.4.1 Summary

CRMs consist of samples that are used to measure the accuracy of analytical processes and are composed of material that has been thoroughly analysed by several laboratories to accurately determine its grade within known error limits. CRMs are inserted by the geologist into the sample stream, and the expected value is concealed from the laboratory. By comparing the results of a laboratory's analysis of a CRM to its certified value, the accuracy of the result is monitored.

A summary of the CRMs used in the Bekisopa South exploration programmes is shown Table 9.5. Akora has used five CRMs during the drilling campaigns. CRMs also used by ALS during internal QC procedures are also included in Table 9.5. OREAS 464 was used in the 2022 drilling campaign during a period of short supply of the previous four OREAS CRMs used in the 2020-2021 drilling campaigns.

Type	CRMS	Reported Grade (Fe %)	Standard Deviation (Fe %)
AKORA	OREAS 40	66.72	0.39
	OREAS 401	45.63	0.257
	OREAS 404	55.14	0.208
	OREAS 701	23.98	0.549
	OREAS 464	35.55	1.569
ALS	OREAS 406	61.44	0.296
	GIOP-111	33.35	0.15
	GIOP-135	53.505	0.08
	NCSDC18014	65.87	0.08
	OREAS 402	48.41	0.298

The review by WAI was performed on all data available to end April 2023 using control charts to monitor CRM performance in comparison to an upper and lower standard deviation boundary. The data from each drill campaign, and laboratory, was reviewed separately. Minor failures were determined based on  $\pm 2$  standard deviations from the reported standard value. Significant failures were determined on  $\pm 3$  standard deviations from the reported standard value.

### 9.7.4.2 2020 Drill Campaign

During the 2020 exploration programme, four different CRMs were utilised for monitoring of assay accuracy at the two laboratories used. All four CRMs were submitted with the samples sent to ALS in Ireland and two of the CRMs were submitted with the samples sent to ALS in Perth. The results and target grades for these CRMs are shown in Table 9.6. Results of the CRM analysis for this campaign are good with no indication of bias. No samples were returned outside of  $\pm 2$  standard deviations.

**Table 9.6: CRM Performance 2020 (Bekisopa South)**

CRM	Assay Lab	Reported Grade (Fe%)	CRM Grade (Fe%)
OREAS 40	ALS (Ireland)	66.66	66.72
OREAS 401	ALS (Ireland)	45.91	45.63
OREAS 404	ALS (Ireland)	55.26	55.14
OREAS 701	ALS (Ireland)	23.42	23.98
OREAS 401	ALS (Perth)	45.71	45.63
OREAS 404	ALS (Perth)	55.26	55.14

#### 9.7.4.3 2021 Drilling Campaign

The results of the CRM analysis for drilling at Bekisopa South in 2021 were reviewed by WAI using control charts to monitor CRM performance in comparison to upper and lower standard deviation boundaries. Any trends and bias in the data over time were also considered in the control charts. The results of the CRM performance are shown in Table 9.7 and graphical analysis is contained in Appendix 2. A total of 96 CRM samples were submitted by Akora during the period. The ALS laboratory in Perth was the only analytical lab used during this period.

**Table 9.7: Summary of Certified Reference Material Assaying in 2021 (Bekisopa South)**

Period	Laboratory	Standard	Grade Fe (%)	Number CRM Samples	Samples Outside $\pm 2$ Standard Deviations		Samples Outside $\pm 3$ Standard Deviations	
					Number Samples	% Samples	Number Samples	% Samples
2021	ALS (Perth)	OREAS 40	66.72	27	5	18.5	1	3.7
		OREAS 401	45.63	23	0	0	0	0
		OREAS 404	55.14	23	3	12.5	0	0
		OREAS 701	23.98	21	0	0	0	0

Results of CRM analysis at ALS Perth laboratory during this period are good with only a small number of failures and no indication of significant positive or negative bias.

OREAS 40 and OREAS 404 are the two CRMs that report failures outside  $\pm 2$  standard deviations, with OREAS 40 being the only CRM with a failure outside  $\pm 3$  standard deviations. The significant failure was identified by onsite geologists and a selection of samples either side of the failure were re-assayed by the laboratory, and the sample database updated with the new values. Lab batches PH22002795 and PH22002792 were re-analysed due to two or more CRM failures and the re-assayed values were included in the sample database (Figure 9.1 and Figure 9.2).

OREAS 401 and 404 returned no results exceeding the  $\pm 2$  standard deviations. There are no obvious systematic errors observed, with failures seemingly occurring randomly. Although a slight negative bias is observed (approximately 0.1%-0.2%), this is not significant and does not compromise the confidence of assays for the resource estimation. WAI considers that the accuracy of assays derived from the ALS laboratory in Perth was to a high standard and no significant issues were identified.

For personal use only

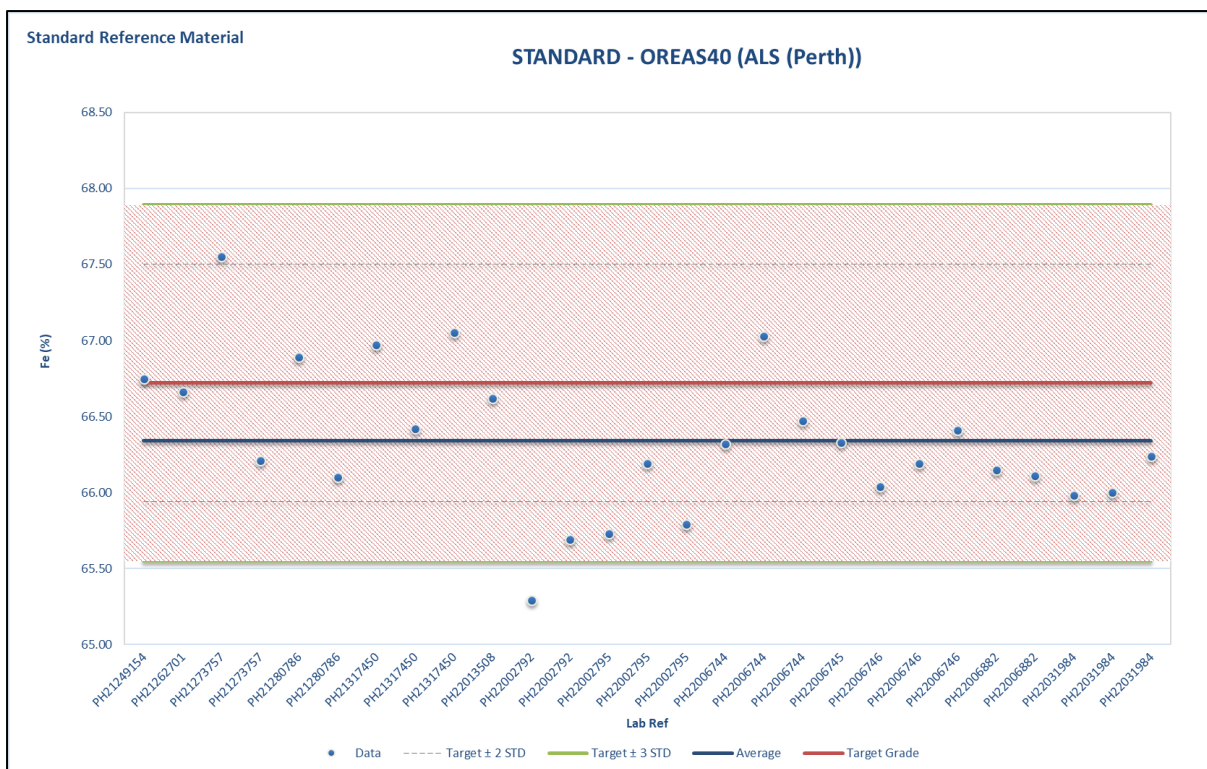


Figure 9.1: Performance of CRM OREAS 40 During 2021 Drilling at Bekisopa South

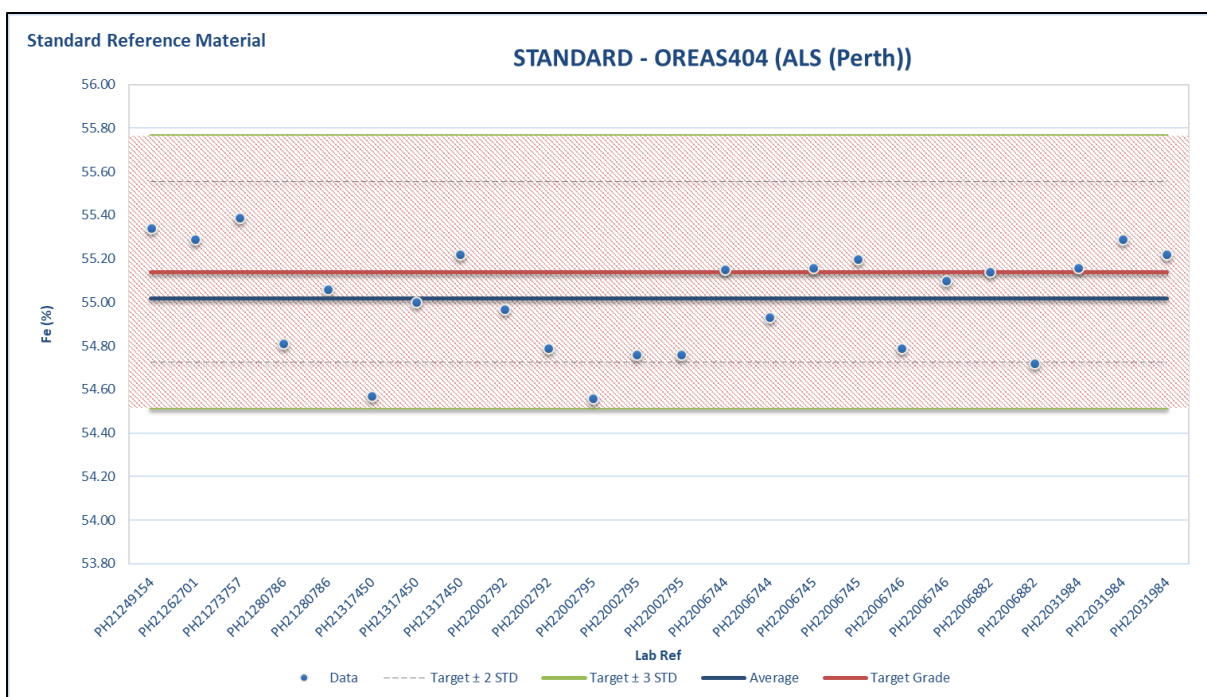


Figure 9.2: Performance of CRM OREAS 404 During 2021 Drilling at Bekisopa South

#### 9.7.4.4 2022 Infill Drilling Campaign

The results of the CRM analysis for drilling at Bekisopa South in 2022 were reviewed by WAI using control charts to monitor CRM performance in comparison to upper and lower standard deviation boundaries. This also included internal ALS QA/QC samples. Any trends and bias in the data over time were also considered in the control charts. The results of the CRM performance are shown in Table 9.8 and graphical analysis is shown in Appendix 2.

A total of 37 CRM samples were submitted by Akora during the period, comprising five certified values. The ALS laboratory in Perth was the only analytical lab used during this period. ALS submitted a total of 74 CRM samples consisting of five types of CRM to monitor accuracy of the Fe % analysis.

**Table 9.8: Summary of Certified Reference Material Results in 2022 (Bekisopa South)**

Period	Laboratory	Standard	Grade Fe (%)	Number CRM Samples	Samples Outside $\pm 2$ Standard Deviations		Samples Outside $\pm 3$ Standard Deviations	
					Number Samples	% Samples	Number Samples	% Samples
2022	ALS (Perth) AKORA QA/QC	OREAS 40	66.72	5	1	20.0	0	0
		OREAS 401	45.63	7	1	14.3	0	0
		OREAS 404	55.14	8	2	25.0	1	12.5
		OREAS 701	23.98	11	0	0	0	0
		OREAS 464	35.55	6	0	0	0	0
2022	ALS (Perth) Internal	OREAS 406	61.44	20	2	20.0	0	0
		GIOP 135	53.51	20	14	70	9	45
		NCSDC18014	65.87	17	11	64.7	6	35.3
		OREAS 402	23.98	12	0	0	0	0
		OREAS 401	35.55	5	0	0	0	0

Results of the CRM analysis at ALS Perth laboratory during this period are good with only a small number of failures and no indication of significant positive or negative bias.

CRM types OREAS 40, OREAS 401 and OREAS 404 reported assay values outside  $\pm 2$  standard deviations with OREAS 404 reporting one assay outside  $\pm 3$  standard deviations of the mean value. Laboratory batches PH23010078 and PH23026294 were re-analysed due to two or more CRM values outside  $\pm 2$  standard, this included the significant failure from OREAS 404 which is shown in Figure 9.3. CRM type OREAS 701 and OREAS 464 had no failures.

Of the internal ALS CRM, OREAS 406, GIOP 135 and NCSDC18014 reported assay values outside  $\pm 2$  standard deviations. The latter two CRMs reported over 60% of samples outside  $\pm 2$  standard deviations and 35% and 45% outside  $\pm 3$  standard deviations respectively. Akora on site geologists identified this and have followed up with the ALS laboratory in Perth. WAI would recommend that the reasons for the consistent failure of these two CRM should be investigated.

OREAS 40 and OREAS 401 are the only samples to return assays outside  $\pm 2$  standard deviations however, there is no obvious systematic error. Although a slight negative bias is observed (approximately 0.1%-0.2%), this is not significant and does not compromise the confidence of assays

for the resource estimation. WAI is of the opinion that the accuracy of analysis at ALS Perth during this period, and throughout the drill campaigns can be considered as acceptable for the purposes of reporting Mineral Resources.

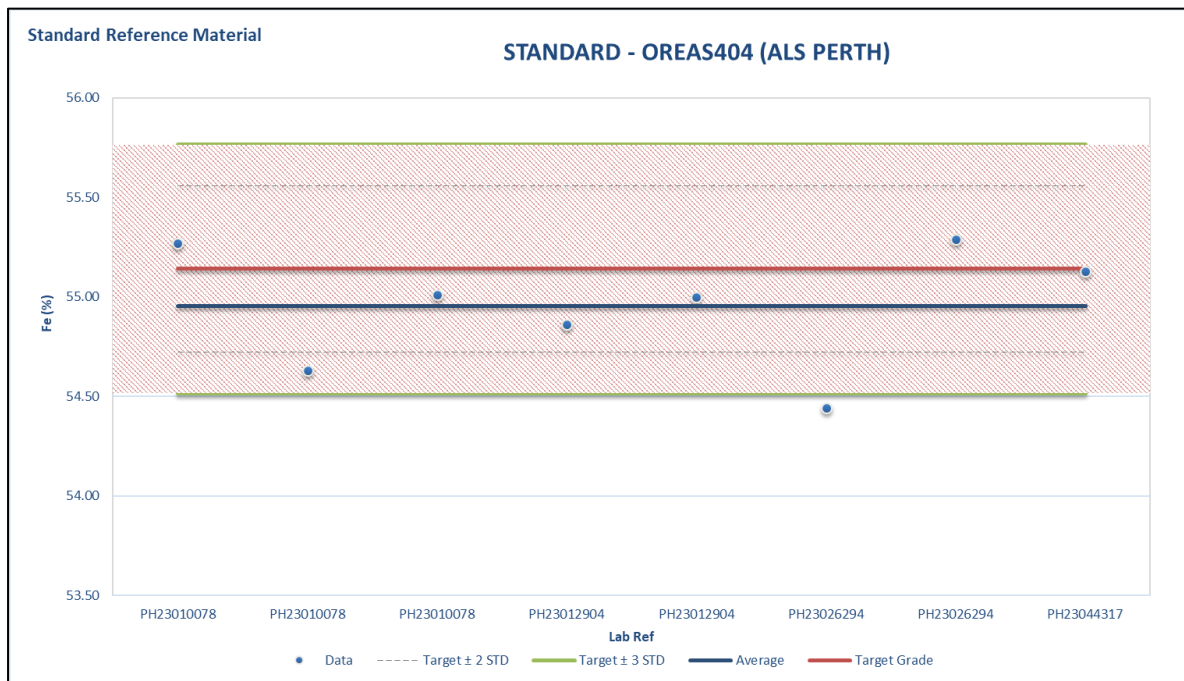


Figure 9.3: Performance of AKORA's CRM OREAS 404 During 2022 Drilling at Bekisopa South

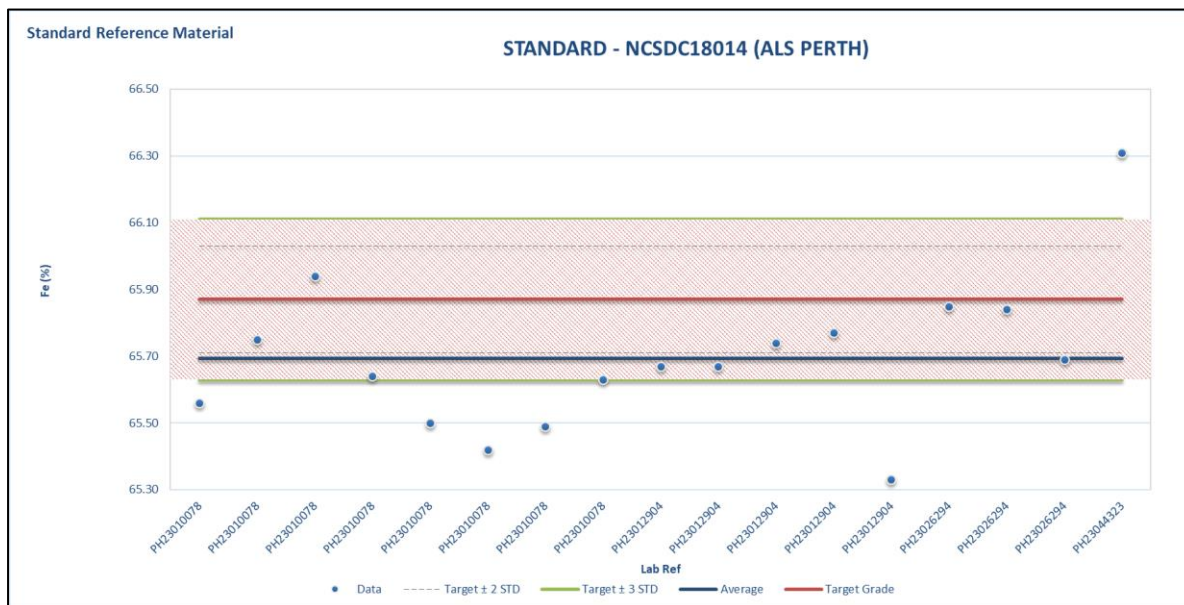


Figure 9.4: Performance of ALS CRM NCSDC18014 During 2022 Drilling at Bekisopa South

For personal use only

## 9.7.5 *Blank Samples*

### 9.7.5.1 *Summary*

Blank samples are composed of material that is known to contain grades that are less than the detection limit of the analytical method. Analysis of blank samples is a method used to monitor sample switching and cross-contamination of samples during the sample preparation or analysis processes.

During drilling of Bekisopa South during 2020-2022, Akora submitted blank samples comprising silica chips manufactured by African Mineral Standards (AMIS0052, AMIS0439, AMIS0681, and AMIS0793). Silica chips have trace amounts of Fe in them, analysed as less than 1%. This is greater than the limit of detection (0.01% Fe) reported by ALS therefore, measuring the performance of blanks in the traditional method against limit of detection is not representative of performance for these samples. Blank samples were treated as low grade CRMs and performance was measured through standard deviations of the target grade reported by the manufacturer. Any trends and bias in the data over time were also considered in the control charts.

ALS submitted internal QA/QC blanks composed of material with grades that are less than the limit of detection for the analytical method. WAI has reviewed the ALS internal blanks for 2022 and found that there are no causes for concern. For ALS internal blanks, failures were determined based on  $\pm 5$  times the assay detection limit with significant failures determined based on  $\pm 10$  times the assay detection limit.

### 9.7.5.2 *2020 Drilling Campaign*

During the 2020 drilling campaign, Akora submitted six blank samples (AMIS0439) to ALS laboratories in Ireland and Perth (three to each laboratory). The mean grade of blanks during this period was 0.44% Fe. WAI considers this reflects trace amounts of Fe in the silica chips and is not suggestive of contamination at either laboratory.

### 9.7.5.3 *2021 Drilling Campaign*

A total of 93 blank samples were submitted by Akora during the 2021 drilling campaign which included 68 samples of AMIS0681 and 25 samples of AMIS0052. The mean grade for all samples of AMIS0681 was 0.68% Fe and 0.35% Fe for all samples of AMIS0052. As with the 2020 drilling, WAI considers these values above the limit of detection reflect trace amounts of Fe in the blank sample and are not reflective of significant contamination.

Figure 9.5 shows the control chart for AMIS0681 which measures the reported assay grade against  $\pm 2$  and  $\pm 3$  standard deviations. An apparent bias is observed which correlates with different sample batches. This may have been caused by changes in the lab equipment/set up as the difference in mean value is subtle, i.e. less than 0.2% Fe difference against the previous batch mean grade.

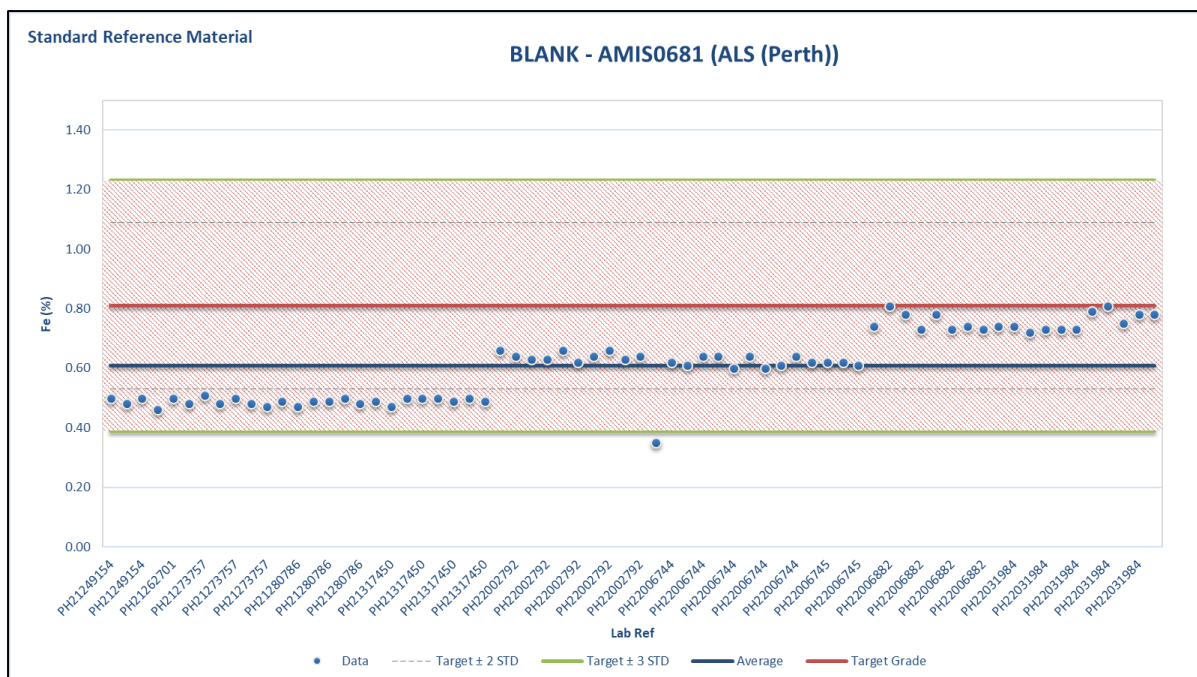


Figure 9.5: Performance of Blank Sample AMIS0681 During 2021 Drilling at Bekisopa South

9.7.5.4 2022 Infill Drilling Campaign

During the 2022 drilling campaign, AMIS0793 was submitted as part of QA/QC sampling. A total of 34 blank samples were submitted with a mean grade of 0.70% Fe. Figure 9.6 summarises the performance of the blank material against  $\pm 2$  and  $\pm 3$  standard deviations.

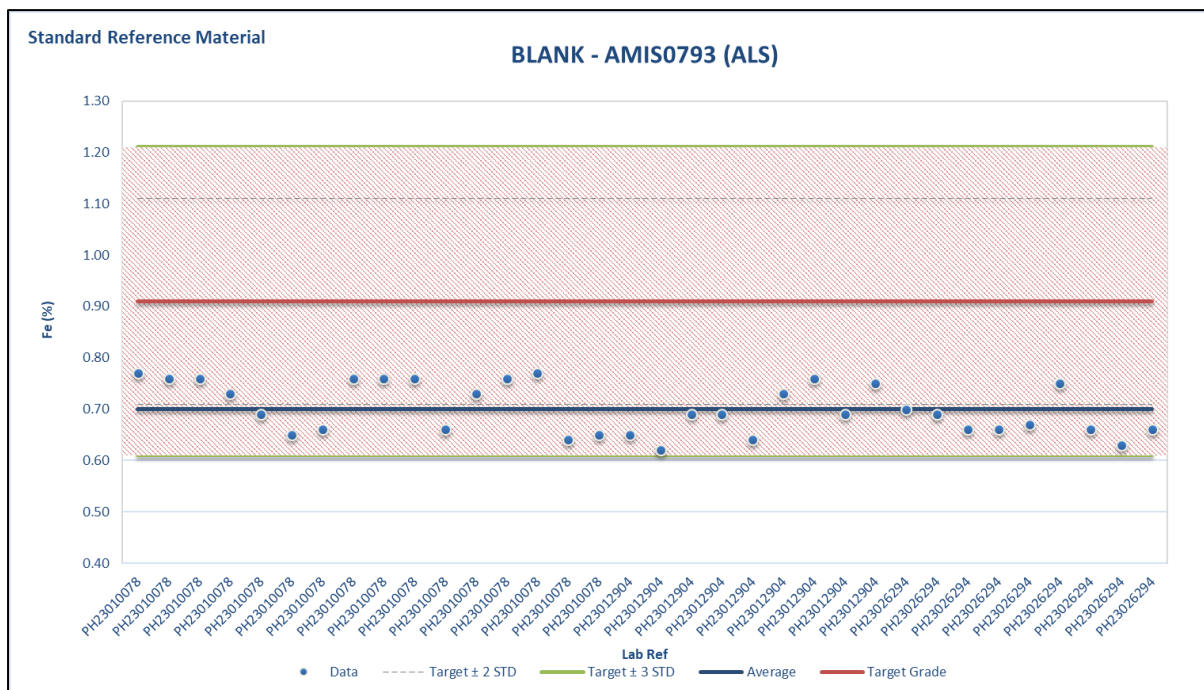
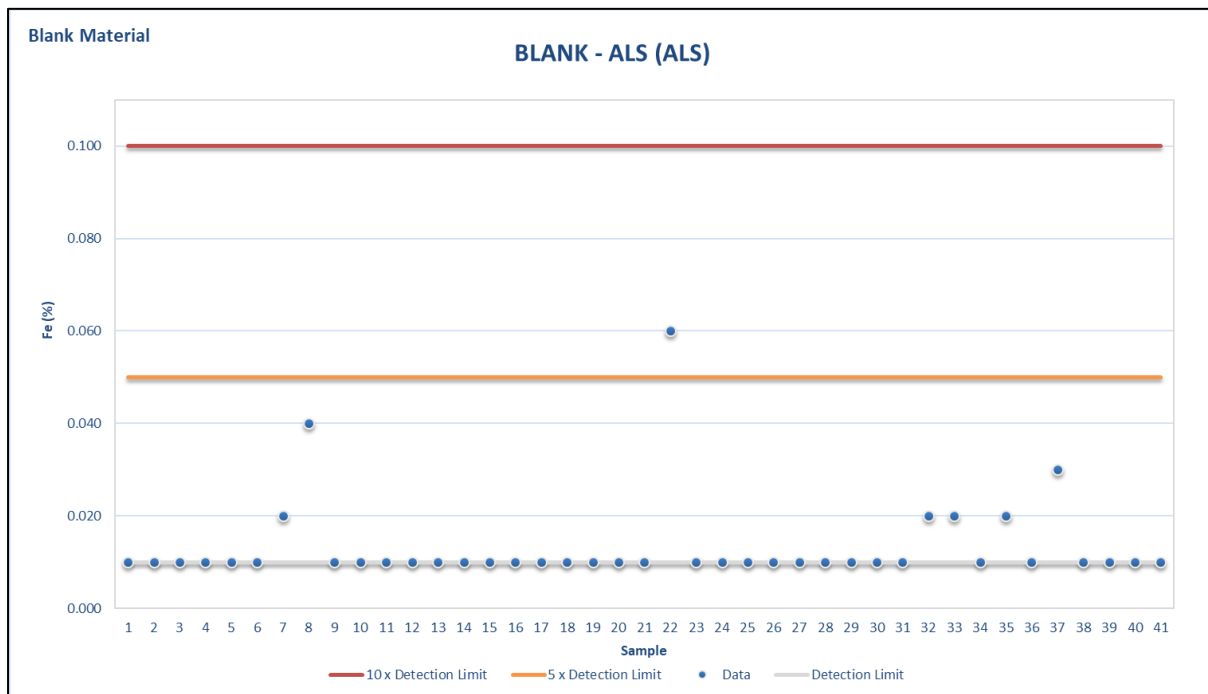


Figure 9.6: Performance of Blank Sample AMIS0793 During 2022 Drilling at Bekisopa South

For personal use only

WAI was able to analyse 41 blank samples submitted internally by ALS Perth during analysis. One Sample was reported with a grade 5x greater than the detection limit and all samples were within 10x the detection limit. This is shown in Figure 9.7.



**Figure 9.7: Performance of ALS Internal Blank Sample During 2022 Drilling at Bekisopa South**

WAI does not consider the performance of blank samples to be of concern. Although some bias is observed in Akora’s samples, all blank samples returned below 1% Fe. Grades reported above the limit of detection are related to known trace amounts of Fe within the silica chips used as proxies for blanks, contamination therefore appears to be minimal and does not impact confidence in the assay results. This is reinforced when comparing blanks used internally by ALS Perth as most of these blank samples had grades less than the limit of detection. However, WAI would recommend following up with the lab to discuss the changes in AMIS0681 assay values between batches to determine the cause.

### 9.7.6 Duplicate Samples

#### 9.7.6.1 Summary

The precision of sampling and analytical results can be measured by re-analysing a portion of the same sample using the same methodology. The variance between the results is a measure of their precision. Precision is affected by mineralogical factors such as grain size, distribution and inconsistencies in the sample preparation and analysis processes. There are several different duplicate sample types which can be used to determine the precision of the sampling process, sample preparation and analyses. A description of the main duplicate types is shown in Table 9.9. A consistent methodology was applied over the course of each drilling campaign.

**Table 9.9: Summary of Duplicate Types**

Duplicate Type	Duplicate Description
Field Duplicate	Sample generated by another sampling operation at the same collection point. Includes a second channel sample taken parallel to the first or the second half of drill core sample and submitted in the same or separate batch to the same (primary) laboratory.
Preparation Duplicate	Second sample obtained from splitting the coarse crushed rock during sample preparation and submitted in the same batch by the laboratory.
Reject Assay	Second sample obtained from splitting the coarse crushed rock during sample preparation and submitted blind to the same or different laboratory that assayed the original sample.
Laboratory Duplicate	Second sample obtained from splitting the pulverised material during sample preparation and submitted in the same batch by the laboratory.
Duplicate Assay	Second sample obtained from splitting the pulverised material during sample preparation and submitted blind at a later date to the same laboratory that assayed the original pulp.
Check Assay	Second sample obtained from the pulverised material during sample preparation and sent to an umpire laboratory.

Duplicate precision levels were also assessed by WAI based on HARD acceptance criteria. To reflect inherent variability of the different sample types, the HARD criteria used would typically vary based on the duplicate type. A summary of the HARD (and equivalent ARD) criteria used in the analysis by WAI is shown in Table 9.10.

**Table 9.10: HARD Acceptance Criteria**

Duplicate Type	Description
Field Duplicate	90% of the population being less than 20% HARD (0.4 ARD)
Preparation Duplicate	90% of the population being less than 15% HARD (0.3 ARD)
Reject Assay	90% of the population being less than 15% HARD (0.3 ARD)
Laboratory Duplicate	90% of the population being less than 10% HARD (0.2 ARD)
Duplicate Assay	90% of the population being less than 10% HARD (0.2 ARD)
Check Assay	90% of the population being less than 15% HARD (0.2 ARD)

WAI has been provided with results of a set of pulp duplicates submitted during the 2020 drilling programme (4 sample pairs), the 2021 drilling programme (76 sample pairs) and, the 2022 drilling programme (28 sample pairs), in addition to ALS Perth internal duplicates in 2022 (101 sample pairs). Field duplicates were not collected by Akora, instead Akora instructed the preparation lab, OMNIS in Antananarivo, to collect reject pulp material as a duplicate sample.

**Table 9.11: Summary of Duplicate Assay Results (Bekisopa South)**

Drilling Campaign	Laboratory	Duplicate Type	Number of Duplicate Pairs	% of Duplicate Pairs Meeting HARD Criteria
2020	ALS Perth	PULP	4	100
2021	ALS Perth	PULP	76	94.7
2022	ALS Perth	PULP	28	100
2022 (ALS Internal)	ALS Perth	PULP	101	100

### 9.7.6.2 2020 Drilling Campaign

A summary of the pulp samples analysed at ALS in Ireland and ALS in Perth for the southern deposit is shown in Table 9.12. Four pulp samples were submitted during this period with one submission to ALS in Perth and three to ALS in Ireland. There is not enough data to make a detailed investigation into the precision of sampling. However, WAI considers the results identify no issues.

Sample No.	Assay Lab	Reported Grade (Fe%)	Duplicate Grade (Fe%)
O7790	ALS (Ireland)	41.53	42.79
O7850	ALS (Ireland)	63.66	63.03
O7890	ALS (Ireland)	55.84	56.86
O7950	ALS (Perth)	65.63	65.17

### 9.7.6.3 2021 Drilling Campaign

A summary of the pulp duplicates analysed at ALS Perth in 2021 for the southern deposit is shown in Figure 9.8. Akora submitted a total of 76 pulp duplicates during the period. Duplicate assays reported the same suite of elements as original samples, however only total Fe (%) is considered in this review. A total of 94.7% of the sample pairs met the HARD criteria of 10% and WAI considers the level of repeatability and precision of sampling to be of a high standard. No bias is seen between the two sets of data. Cumulative frequency plots and correlation plots show a reasonable match between the two data sets. Sample pairs showing the highest variability are all lower than the cut-off grade.

### 9.7.6.4 2022 Infill Drilling Campaign

A summary of the pulp duplicates analysed at ALS Perth and ALS internal duplicate samples are shown in Figure 9.9. Akora submitted 28 pulp duplicates and ALS submitted 101 pulp duplicates into their sample stream. Sample pairs for both data sets achieved 100% within the HARD criteria. WAI considers the level of precision to be of a high standard. No bias is seen between the two sets of data. Cumulative frequency plots and correlation plots show a reasonable match between the two data sets.

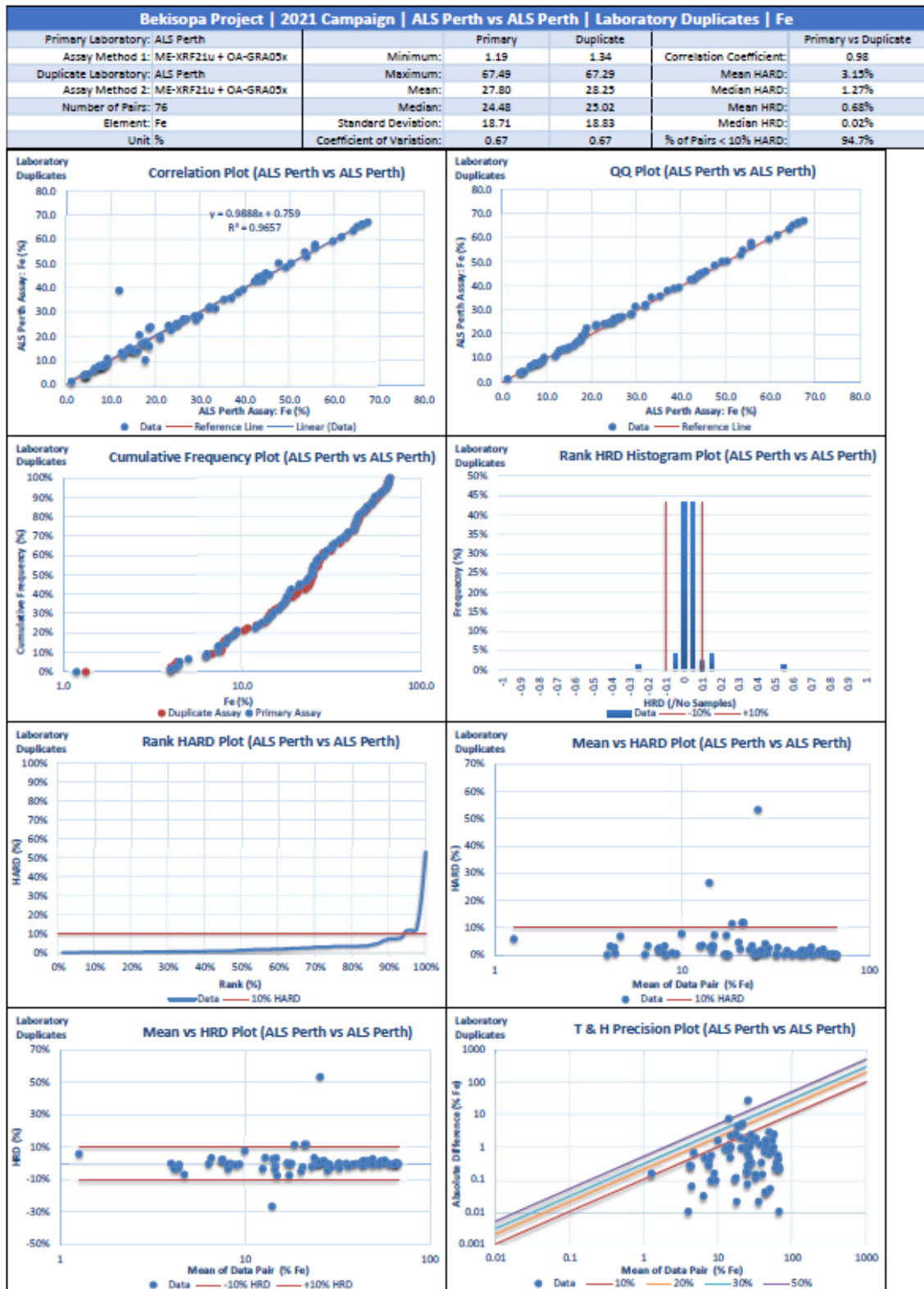


Figure 9.8: Performance of Akora Duplicate Samples during 2021 drilling at Bekisopa South

For personal use only

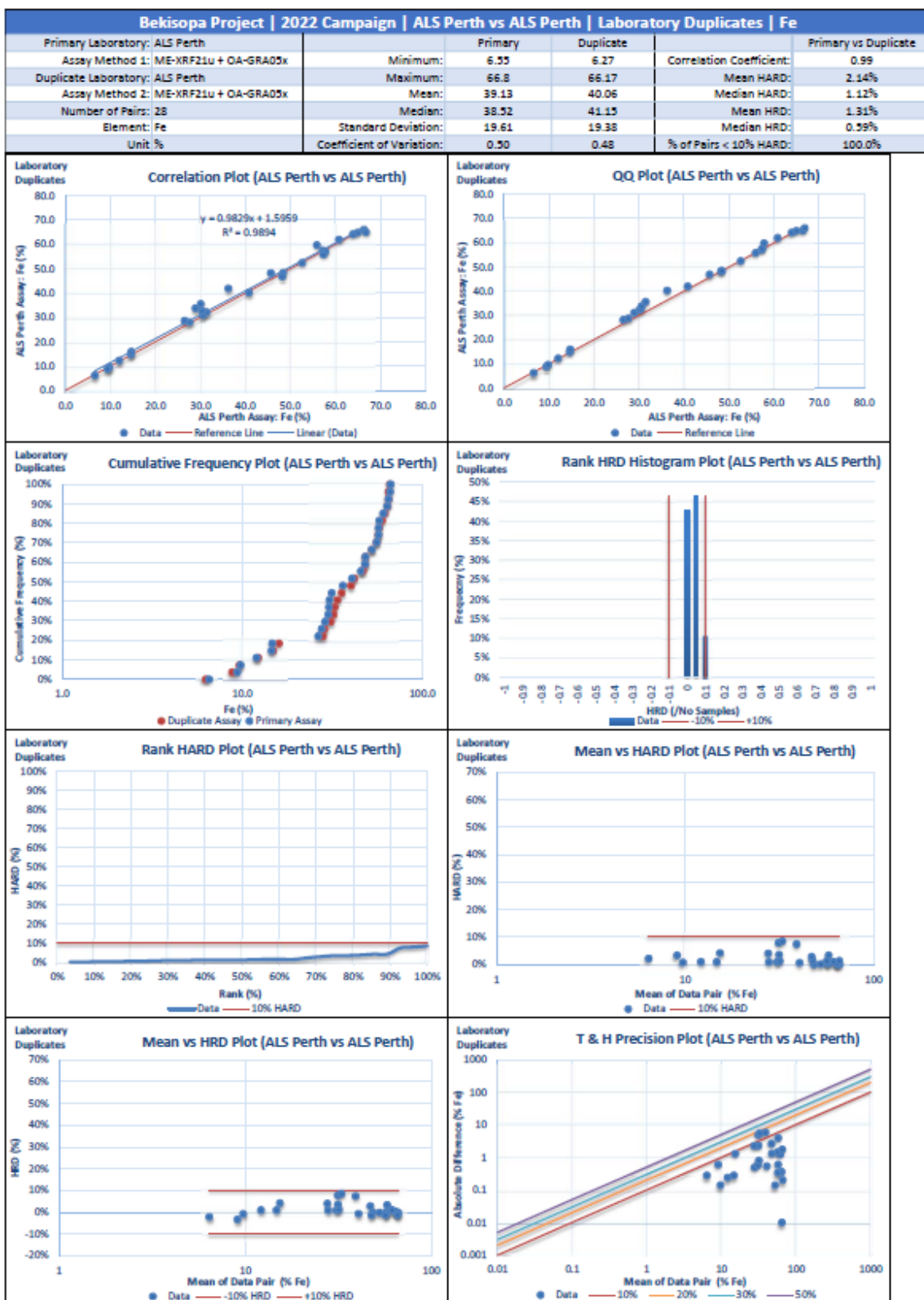


Figure 9.9: Performance of Akora Duplicate Samples during 2022 Drilling at Bekisopa South

For personal use only

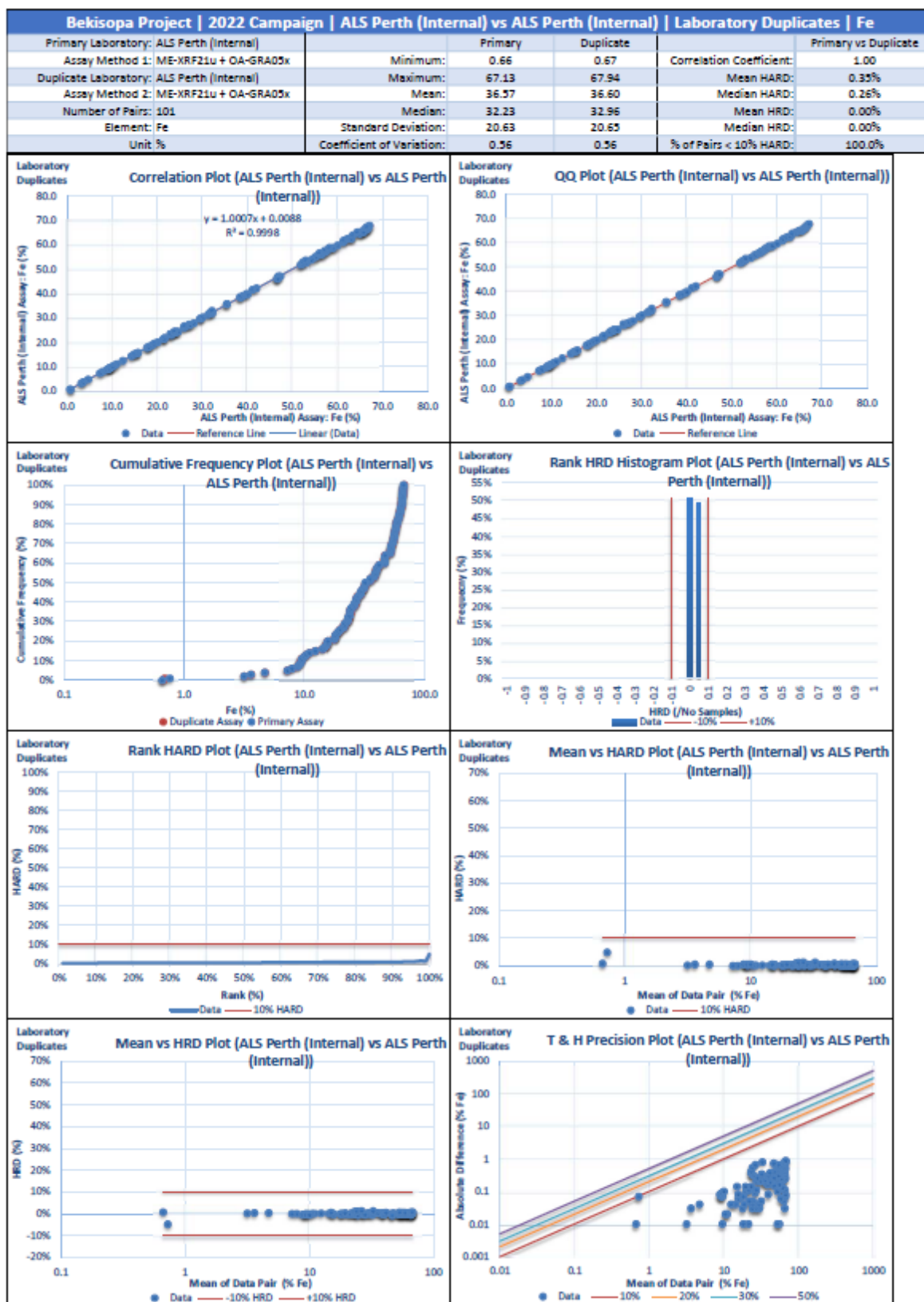


Figure 9.10: Performance of ALS Duplicate Samples during 2022 Drilling at Bekisopa South

For personal use only

### 9.7.7 Conclusions

Akora's QA/QC protocol for the drillholes at Bekisopa South during the 2020 drilling campaign consisted of six CRMs, four duplicates, and six blank samples that were analysed at ALS Perth and ALS Ireland. WAI was able to review these data and considers the QA/QC samples performed to a high standard.

Akora's QA/QC protocol for the drillholes at Bekisopa South during the 2021 drilling campaign consisted of 96 CRMs, 76 duplicates, and 93 blank samples that were analysed at ALS Perth. Two CRM samples reported grades outside  $\pm 2$  standard deviations, with one CRM sample reporting grades outside  $\pm 3$  standard deviations. These results were identified by Akora geologists, and the appropriate batches were sent for re-analysis. The sample database was updated with the re-assayed results.

A total of 94.7% of duplicate pairs met the HARD criteria suggesting precision of sampling is of good quality. Blank samples consisted to silica chips with trace amounts of Fe, however, all blank assays were reported at  $<1\%$  Fe and do not suggest any significant contamination between samples has occurred.

WAI was able to review Akora's QA/QC protocols for the drillholes in Bekisopa South during the 2022 drilling campaign in addition to ALS Perth internal QA/QC procedures. Akora's QA/QC sampling consisted of 37 CRM, 28 duplicates, 34 blank samples, along with 74 CRM, 101 duplicates, and 41 blank samples submitted and analysed at ALS Perth.

Similarly, to 2021, two CRM samples reported grades outside  $\pm 2$  standard deviations, with one CRM sample reporting grades outside  $\pm 3$  standard deviations. These results were identified by Akora geologists, and the appropriate batches were sent for re-analysis. The sample database was updated with the re-assayed results. Two CRM samples submitted internally by ALS reported over 60% of samples outside  $\pm 2$  standard deviations and up to 45% outside  $\pm 3$  standard deviations. Akora has followed this observation up with the laboratory and WAI recommends this is reviewed.

A total of 100% of duplicate pairs for both Akora and internal ALS samples met the HARD criteria suggesting precision of sampling is of high quality. Blank samples consisted to silica chips with trace amounts of Fe however all blank assays were reported at  $<1\%$  Fe and do not suggest any significant contamination has occurred. This is reinforced by ALS internal blank samples which reported only one sample above 5x the detection limit. WAI recommends that field duplicates are also taken to ensure that sample collection methodology is representative.

WAI considers the QA/QC risk for the assay data pertaining to Bekisopa South to be low and that the sample preparation procedures and analytical methods are sufficiently robust for these data to be used in the estimation of Mineral Resources.

### 9.8 Twin Holes

Twin holes were not purposely drilled by Akora, however, two drillholes have been redrilled providing close spaced data and the opportunity to analyse these drillholes as if they were twinned. Table 9.13 summarises the two drillholes that were re-drilled.

Pair No	Hole ID	Status	X (m)	Y (m)	Z (m)	Depth (m)	Hole Type
1	43		586,548.19	7,608,150.44	851.91	195.61	DD
	43A		586,549.85	7,608,150.38	852.04	50.64	DD
2	119		586,397.75	7,607,749.21	852.21	11.61	DD
	119A		586,397.82	7,607,749.99	852.21	5.61	DD

Figure 9.11 shows the downhole trace of the ‘twinned’ drillholes which compares grade through a mineralised zone. Although some variation exists, the distribution of grades generally matches down hole indicating little variability in short scale distances in mineralisation.

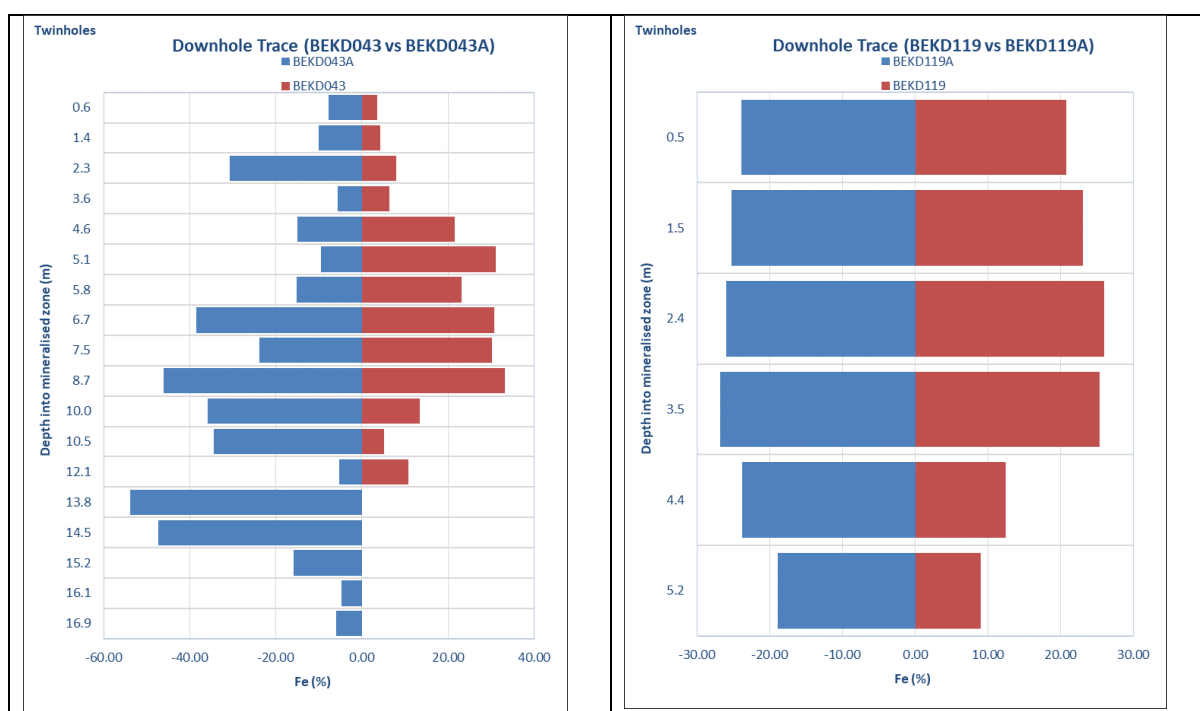


Figure 9.11: Comparison of Downhole Fe Grades for BEKD043 and BEKD043A (left) and BEKD119 and BEKD119A (right)

### 9.9 Summary

A summary of the data verification and review of the QA/QC data for the Bekisopa South Project is detailed below:

For personal use only

- The drilling database has been reviewed and was checked during import into software for overlapping/duplicate data, drillholes with samples that extend beyond the length of the drillhole, in addition to grade values and positions being within expected limits;
- The topographic survey produced from FuturMap's drone survey matches reasonably well with drillhole collar positions;
- Although twin drilling has not been intentionally drilled, a local comparison of re-drilled holes gives a reasonable comparison of iron grade distribution; and
- QA/QC protocols are sufficiently robust and an analysis of the performance of QA/QC samples indicating that the assay data is acceptable for use in Mineral Resource estimation.

For personal use only

## 10 MINERAL PROCESSING AND METALLURGICAL TESTWORK

### 10.1 Introduction

The iron mineralisation at Bekisopa is predominantly magnetite-based and the following main ore types have been identified:

- DSO - near surface high grade weathered zone from which DSO material is expected to be selectively mined for production as conventional lump and fines products through simple dry crushing and screening. The DSO is a mixture of hematite and magnetite mineralisation with grades of around 60% Fe.
- Massive magnetite – found below the DSO and comprising weathered and unweathered mineralisation with grades of around >45% Fe.
- Disseminated:
  - Coarse disseminated with grades of around 30% - 45% Fe; and
  - Fine disseminated with grades of around 25% Fe.

Simple crushing and screening are deemed sufficient for the DSO material. As part of the October 2022 Scoping Study two options for processing the non-DSO material were considered as follows:

- Simple dry crushing to 2mm followed by a dry low intensity magnetic separation process (LIMS). This will produce concentrates grading typically 62-65% Fe. The 2mm dry non-magnetic tailings will be stockpiled as waste and the dry concentrate trucked to the port;
- Processing to produce "green steel" concentrate at a grade of >67% Fe. This will require crushing and fine wet grinding to 75 microns, followed by conventional wet high intensity magnetic separation ("WHIMS"), with the non-magnetic tailings stored in a conventional Tailings Storage Facility ("TSF"). The magnetic concentrate will be filtered and trucked to the port and loading facility.

WAI understands that the WHIMS option is currently considered by Akora as the preferred process route.

The following sections are based on the October 2022 Scoping Study. Additional magnetic susceptibility and DTT recovery information is now available and is presented in Section 11.3.2 and is planned to be incorporated as part of an updated Scoping Study in 2023.

### 10.2 Metallurgical Testwork

Based on the October 2022 Scoping Study, testwork results for the two non-DSO process options for various samples from different drillhole sources (different zones and depths) are summarised in the Table 10.1.

Table 10.1: Summary of Specific Testwork Results					
Dry crush (2mm) + wet LIMS					
Drillhole Source	Zone	HG % Fe	Fines % Fe	Rec Fe %	Mass Yield %
BEKD01/04/10/34 (0-37m)		45.6	64.3	91.7	65.0
BEKD04 (0-38m)	Central	35.1	66.1	90.2	47.9
BEKD01	Northern	35.0	63.9	90.0	49.3
BEKD09/10/11	Southern	60.0	66.9	84.0	75.3
BEKMETF01-09 + 12		48.6	62.8	82.8	64.1
DTT (75 microns wet grind + WHIMS)					
Drillhole Source	Zone	HG % Fe	Conc % Fe	Rec Fe %	Mass Yield %
BEKD01/04/10/34 (0-37m)		45.6	69.7	82.5	54.0
BEKD04	Central	27.0	71.0	81.0	31.0
BEKD04 (0-38m)	Central	35.1	70.2	84.6	42.3
BEKD04 (72.6-100.5m)	Central	29.3	69.9	78.0	32.7

The results demonstrate that in general and as expected, for the finer wet grind option, mass and iron recoveries decrease for the benefit of higher achieved concentrate grades for green steel production. Also, for both options, the mass yield to concentrate decreases significantly at lower head grades.

A crush size of 2mm was selected based on initial trials at different crush sizes, but both the 2mm and 75-micron sizes (for the fine wet grinding option) are non-optimised and will be the subject of further testwork and trade-off studies in the next phase of study.

For both options, excellent iron product grades were achieved at low impurity levels. For the 2mm crush and wet LIMS option, fines product grades in the general range of 62-66% Fe were achieved from varying head grades. For the fine grind and WHIMS option, concentrate grades circa 70% Fe were achieved, at the expense of lower mass and iron recovery.

The results for the BEK01/04/10/34 data have been used for process design and financial modelling purposes. As well as the composite sample having been tested for both the process options, allowing for the financial trade-off to be evaluated, the composition of the samples was taken from four bore holes representing the different areas of the project: namely, Hole 01 came from the North, Hole 04 from the Central, Hole 10 from the southeast and Hole 34 from the southwest areas.

The head grade of the composite sample was 45.6% Fe and is considered representative of the massive and coarse disseminated mineralisation at this stage of study. It should be noted that, from the testwork results, any decrease in this average resource grade would require the use of lower mass recoveries, as indicated in the table of results, resulting in higher plant throughputs to achieve the required concentrate production of 2Mtpa (the larger plant would have a larger capex, but lower unit operating cost).

The results for this composite sample also showed low impurity levels for both process options: for the 2mm crush and wet LIMS option, for the 64.3% Fe fines product, there was 3.2% silica, 1.3%

alumina, 0.046% P and 0.02% S; for the -75-micron wet grind and WHIMS option (DTT), for the concentrate grade of 69.7% Fe, there was 0.7% silica, 0.6% alumina, 0.002% P and 0.005% S. At higher concentrate grades of circa 70% Fe, these impurity levels were further reduced.

Additional information is detailed in Table 10.2. In total, 11 drillholes were completed to intersect iron mineralisation at depths of up to 100m and encompassed both the massive and coarse disseminated iron mineralisation.

<b>Table 10.2: Summary of Impurity Levels from the 2mm/LIMS Option from the Results of the 2020 BEKMET Series of Bore Hole Samples</b>								
Sample	Product Grade %					Fe Rec %	HG % Fe	Mineralisation
	Fe	P	S	SiO <sub>2</sub>	Al <sub>2</sub> O <sub>3</sub>			
BEKMETF01	60.7	0.05	2.06	5.4	1.1	92.9	43.6	Massive
BEKMETF02	66.5	0.05	1.78	1.7	0.6	90.6	58.2	Massive
BEKMETF03	68.3	0.03	0.06	1.7	1.4	88.1	61.8	Massive
BEKMETF04	66.9	0.02	0.01	2.0	2.2	83.9	60.0	Massive
BEKMETF05	65.1	0.05	0.15	2.6	0.6	58.9	61.0	Massive
BEKMETF06	63.4	0.05	0.05	4.6	1.2	95.7	41.2	Coarse Disseminated
BEKMETF07	60.2	0.05	1.30	6.2	1.1	91.0	39.5	Coarse Disseminated
BEKMETF08	54.1	0.06	0.05	12.2	1.6	76.9	41.6	Coarse Disseminated
BEKMETF09	63.9	0.04	0.30	4.4	1.3	90.4	40.4	Coarse Disseminated
BEKMETF12	59.3	0.05	0.02	7.1	1.7	59.3	38.7	Coarse Disseminated
<b>Average</b>	<b>62.8</b>	<b>0.05</b>	<b>0.58</b>	<b>4.8</b>	<b>1.3</b>	<b>82.8</b>	<b>48.6</b>	

From an average calculated head grade across the massive and coarse disseminated mineralisation of 48.6% Fe, fines product grading 62.8% Fe were achieved at 82.8% Fe recovery and a mass yield of 64.1%.

The results importantly show that the levels of impurities are acceptable from the 2mm dry crush and wet LIMS process route. The average P content is low at 0.05% and the combined silica and alumina content is also low at 6.1%. The average sulphur content at 0.58% is also within the specification of 0.6% S.

For similar iron recoveries, the massive mineralisation gave higher concentrate grades due to the higher head grades.

Mineralogically, four samples of -1mm LIMS concentrates (two weathered and two fresh samples) were submitted to ALS for mineralogical analysis. In all four samples, magnetite was the principal iron-bearing mineral in the concentrates, varying in content from 83-89%, relatively coarse grained and well liberated.

### 10.3 Recovery Methods

#### 10.3.1 DSO Material

DSO material will be mined and processed through a simple crushing and screening plant to produce conventional lump and fines products (lump is -31.5+6.3mm; fines is -6.3mm). A 50:50 split of lump: fines has been assumed. For the required product rate of 2Mtpa (1Mtpa each of lump and fines), 2Mtpa will be processed through the plant at 100% recovery.

It is anticipated that DSO material will suffice for the early years of operation (and could be extended with additional exploration) before the switch to processing of the massive and coarse disseminated mineralisation.

This is important as, for a relatively low capital cost requirement, cashflow can be quickly generated and used to conduct the more detailed studies and testwork required for the main processing options to follow once the DSO material has been exhausted.

With a typical crushing circuit availability of circa 75%, this equates to 300tph for 2Mtpa throughput. On this basis, and for a typical fixed plant, the main equipment required (indicative) will typically be a Metso C100 jaw crusher (110kW), an HP400 cone crusher (315kW), a 6.35m x 2.445m triple-deck horizontal screen (30kW) and the associated conveyors and feeders (approximately 170kW). Therefore, the total installed power will be circa 625kW (indicative).

With the expectation of installing a solar power station, the energy consumption will therefore be very low and effectively free once the capital cost for the solar farm has been expended.

As an alternative to a fixed plant, it may be desirable to design for portable crushing, screening and conveying units, so that the plant can be moved as required to different areas of the Project. It may even be desirable to have two half-capacity portable plants working at different areas simultaneously. This can be further investigated in the next phase of study - for now, a conventional fixed plant is assumed.

The Block Flow Diagram of the typical circuit employed is shown Figure 10.1.

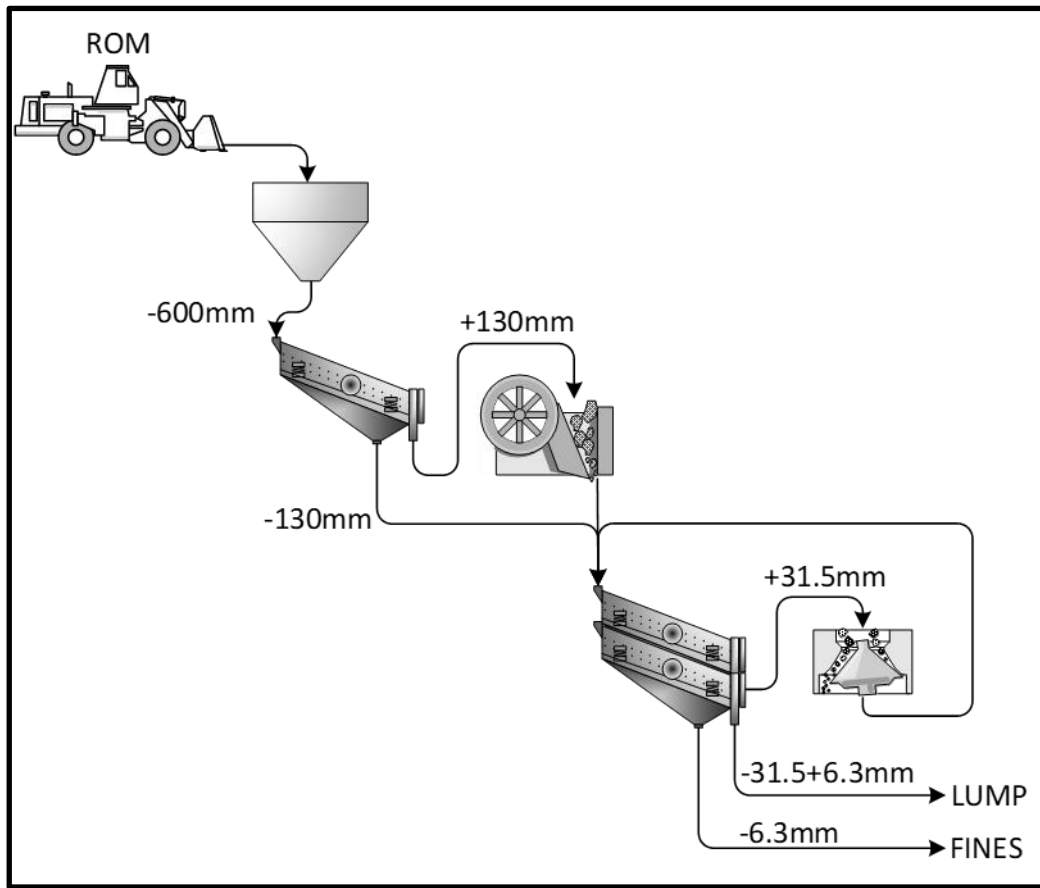


Figure 10.1: Block Flow Diagram of the Typical Circuit for DSO Material

### 10.3.2 2mm Crush and Dry LIMS Option

With this option, based on the testwork results (65% mass recovery to a fines product grading 64.3% Fe), a plant throughput of 3.1Mtpa is required to produce 2Mtpa of concentrates.

At this stage of study, it is assumed that conventional primary and secondary crushing and screening will be required, followed by a High-Pressure Grinding Roll (HPGR) unit to achieve the -2mm crush size required. This will then be followed by a dry LIMS process to produce a 2mm magnetic concentrate for trucking to the port and loading facility. The non-magnetic 2mm tailings will be transported either by truck or conveyor to a waste stockpile facility.

As with the DSO option, this is a very simple circuit. At this stage, dry LIMS (rather than wet LIMS) is assumed (the laboratory tests used wet LIMS), but this is commercially used in industry and will be confirmed by testwork in the next phase of study.

For the throughput of 3.1Mtpa and a higher required plant availability of 85% (as the circuit is still predominantly a crushing circuit), then the average required throughput is 416tph. For the higher throughput compared to the DSO option, and with a typical 1.45m diameter x 0.9m width HPGR unit with 2 x 650kW motors and a LIMS circuit consisting of 4 units, each of 1.2m diameter x 3m length with 7.5kW motors, then the total installed power is approximately 2MW.

At this stage, only a single stage of LIMS is assumed. Testwork in the next phase of study will determine if more stages are required for upgrading to the required fines product grade using dry LIMS (or wet LIMS if required). The Block Flow Diagram of the expected flowsheet is shown in Figure 10.2.

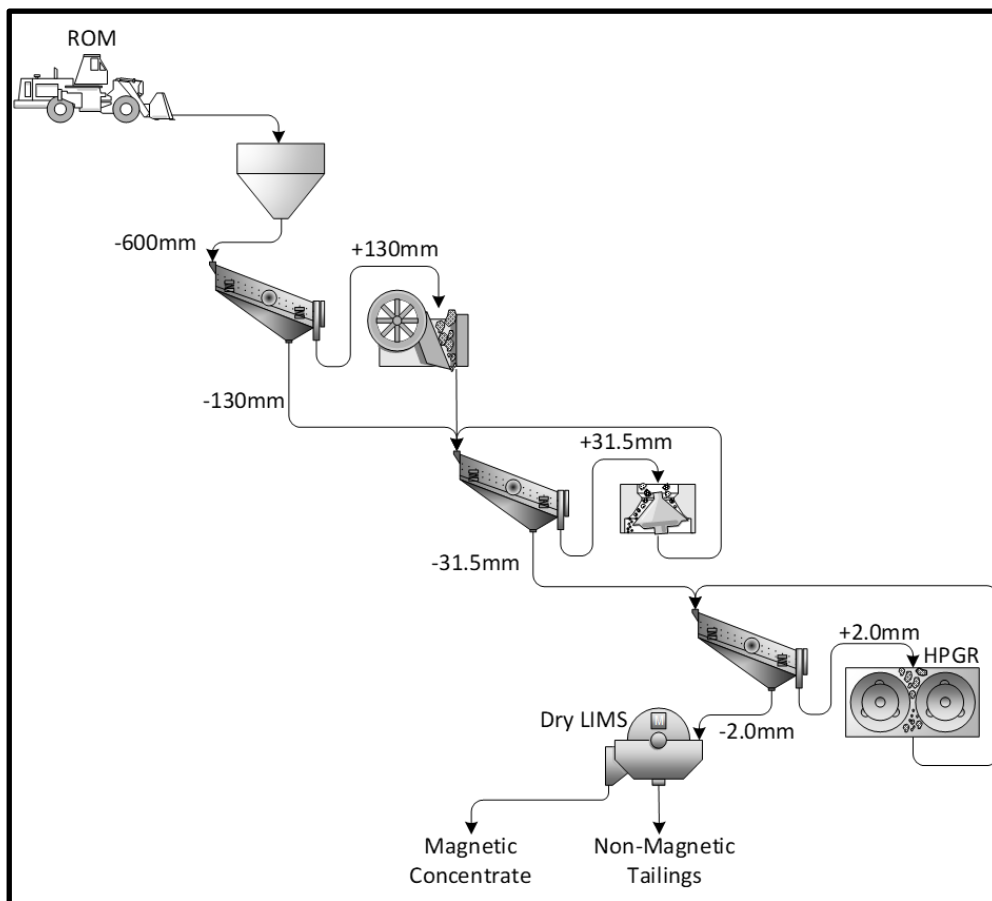


Figure 10.2: Block Flow Diagram of the Typical Circuit for 2mm Crush and Dry LIMS Option

### 10.3.3 Fine Grind and WHIMS Option

For this option, in order to achieve concentrate grades of circa 70% Fe suitable for green steel production, then the ore requires fine grinding to minus 75 microns, followed by conventional WHIMS processing. Based on the testwork results (54% mass recovery to a concentrate grading 69.7% Fe), a plant throughput of 3.7Mtpa is required to produce 2Mtpa of concentrates.

In this case, it is prudent to allow for a crushed ore stockpile after crushing, with an assumed plant availability for the crushing circuit of 75% and a ball milling/WHIMS circuit availability of 92%. Therefore, the throughput rates required are 563tph and 459tph respectively.

In order to supply conventional ball mill feed, a three-stage conventional crushing circuit is required to produce a -6.3mm crushed product. The secondary crusher will operate in open circuit with the tertiary crusher in closed circuit.

In the next phase of study, a trade-off study to evaluate a primary crusher and SAG mill option is recommended.

Crushed product at -6.3mm will be stockpiled and fed via belt feeders to a mill feed conveyor belt and hence to a Ball Mill. The mill will operate in closed circuit with hydrocyclones to achieve a grind size of 80% passing 75 microns.

The cyclone overflow will then report to the WHIMS circuit. The magnetic concentrate will be filtered and then trucked to the port and loading facility. The non-magnetic tailings slurry will be thickened and pumped to the conventional TSF. Return water from the TSF will be pumped back to the process water tank.

At this stage, a flotation circuit is assumed as not required, due to low levels of silica impurities and the expectation that any high-sulphur lenses of ore can either be left in situ or blended with ROM ore.

Based on an assumed Bond Mill Work Index of 17kWh/t (to be determined in the next phase of study) with an 80% passing feed and product size of 6.3mm and 75 microns respectively, then an indicative ball mill required size is 6.7m diameter x 11.1m length with an 8.5MW motor. The power requirement for the required WHIMS unit would be in the order of 500kW. In total, the plant installed power is therefore likely to be in the order of 10MW.

The Block Flow Diagram of the expected flowsheet is shown in Figure 10.3.

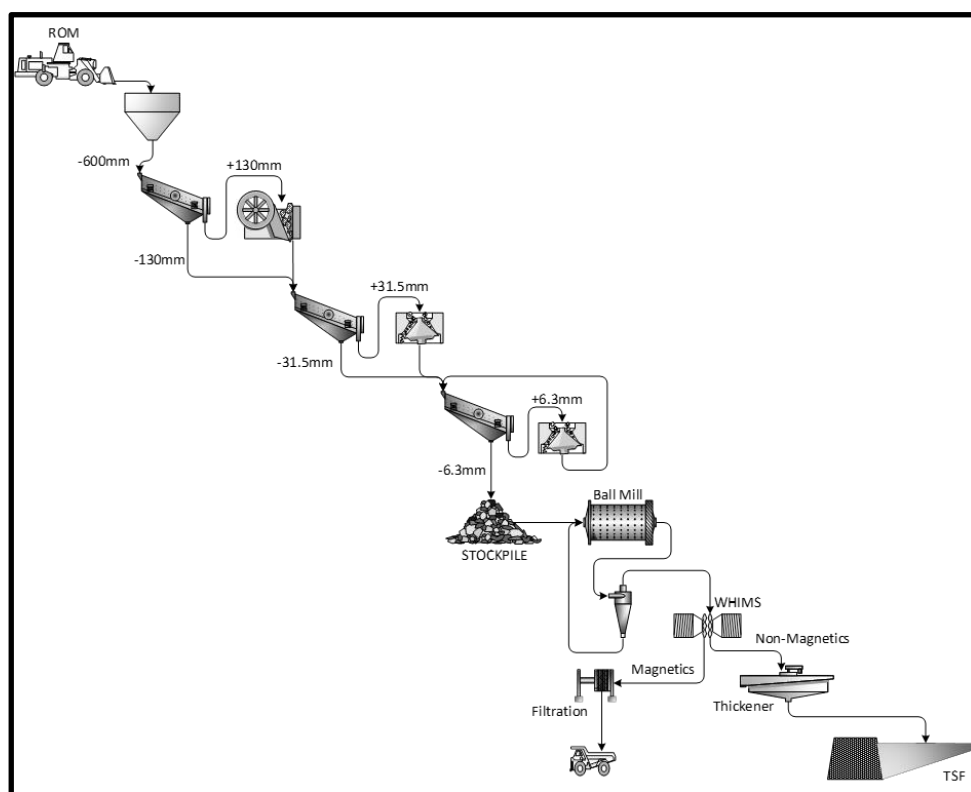


Figure 10.3: Block Flow Diagram of the Typical Circuit for Fine Grind and WHIMS Option

## 11 MINERAL RESOURCE ESTIMATE

### 11.1 General Methodology

The following chapter describes the process of Mineral Resource estimation for the Bekisopa South Iron Project. WAI was commissioned to produce this estimate to be carried out in accordance with the guidelines of the JORC Code (2012).

The MRE was carried out with a 3D block modelling approach using Datamine Studio RM and Snowden Supervisor software. Exploration data were imported and verified before geological and mineralisation envelopes were defined by creating 3D wireframes based on a nominal cut-off grade of 58% Fe for DSO material and a cut-off grade of 25% Fe for the non-DSO material ("Green Steel" zone).

Sample data were selected using the geological and mineralisation wireframes and selected samples were assessed for outliers before being composited as the basis for geostatistical study. The wireframe envelopes were used as the basis for a volumetric block model based on a parent cell size of 20m x 20m x 5m. Grades for Fe, SiO<sub>2</sub>, Al<sub>2</sub>O<sub>3</sub>, Mn, P, and TiO<sub>2</sub> were estimated into the block model from drillhole data using the mineralised domains as hard boundaries. Density was estimated into the block model from drillhole data based on regressed density values from iron grades and using the mineralised domains and weathering surfaces as hard boundaries. The resultant estimated values were validated against the input composite data. Mineral Resource classification followed the guidelines of the JORC Code (2012) based on an assessment of geological and grade continuity and an assessment of assay quality. Mineral Resources were further limited based on an expectation of eventual economic extraction to an optimised open pit shell generated using appropriate economic and technical parameters.

### 11.2 Data Transformations and Software

#### 11.2.1 Data Transformations

The co-ordinate system used is based on the Universal Transverse Mercator (UTM) projection. The area of Bekisopa is located within UTM Zone 38S.

#### 11.2.2 Software

The MRE has relied on several software packages for the various stages of the process. Data preparation and validation, block modelling, grade estimation, Mineral Resource classification and validation were performed in Datamine Studio RM and statistical and variographic analysis was performed in Supervisor. Pit optimisation for the limitation of Mineral Resources was performed in NPV Scheduler.

### 11.3 Sample Data Processing and Interpretation

#### 11.3.1 Exploration Database

##### 11.3.1.1 Input Data

The exploration database was supplied by the Client in Microsoft Excel format with separate files for collar, downhole survey, assay, lithology, density, geotechnical and magnetic susceptibility information for all areas of exploration data combined. The relevant imported data in each of these files are listed in Table 11.1. Assay data is available for a full suite of elements. Davis Tube Recovery data (DTT) was also available. Only data from Bekisopa South has been used in this MRE.

Collar File		Assay File		Davis Tube File	
Column	Explanation	Column	Explanation		
BHID	Hole number	BHID	Hole number	BHID	Hole number
XCOLLAR	Collar easting	FROM	Interval from	FROM	Interval from
YCOLLAR	Collar northing	TO	Interval to	TO	Interval to
ZCOLLAR	Collar elevation	SAMPNUM	Sample number	SAMPNUM	Sample number
DEPTH	Length of hole	H_FE_PCT	Fe % head assay	FEED MASS (g)	Weight of sample feed mass
SIZE	Core diameter	<b>Density File</b>		MAGS (g)	Weight of recovered magnetic fraction
YEAR	Year drilled	BHID	Hole number	MAGS DISTn. %	Magnetic distribution %
LOGGEDBY	Logging geologist	FROM	Interval from	DTT rec %	% of magnetic fraction in sample
<b>Survey File</b>		TO	Interval to	H_FE	Fe % head assay
BHID	Hole number	LITH	Lithology	C_FE	Fe % concentrate assay
AT	Survey depth	ASSAY_FE	Fe % head assay	C_SiO <sub>2</sub>	SiO <sub>2</sub> % concentrate assay
BRG	Survey bearing	DENSITY	Measured density	C_P	P % concentrate assay
DIP	Survey dip	<b>Geotechnical File</b>		C_S	S % concentrate assay
<b>Lithology File</b>		BHID	Hole number	C_TiO <sub>2</sub>	TiO <sub>2</sub> concentrate assay
BHID	Hole number	FROM	Interval from	<b>Magnetic Susceptibility File</b>	
FROM	Interval from	TO	Interval to	BHID	Hole number
TO	Interval to	TCR_M	Recovered Length	FROM	Interval from
LITH	Lithology	TCR_PCT	Recovered %	TO	Interval to
SUBLITH	Secondary Lithology		Combined length of core pieces >10cm	VALUE	(10-3SI)
FINALLITH	Final lithology	RQD %	RQD %		
WEATH	Degree of weathering				

For personal use only

### 11.3.1.2 Database Summary

A summary of the exploration database used in during this Mineral Resource Estimate is shown in Table 11.2. There have been three phases of drilling carried out and include 2020, 2021 and 2022. In total the database for this MRE comprises 123 diamond drillholes totalling at 3,816.93m at Bekisopa South. This includes a total sample count of 3,738 samples, in addition to 2,178 DTT samples.

<b>Table 11.2: Composition of Exploration Database</b>						
<b>Year</b>	<b>Contractor</b>	<b>Type</b>	<b>No Holes</b>	<b>Total Metres Drilled (m)</b>	<b>No Samples</b>	<b>No DTT* Samples</b>
2020	Croft Drilling Services	Diamond	4	401.75	224	154
2021	Croft Drilling Services	Diamond	33	3,248.81	2,370	2,024
2022	Croft Drilling Services	Diamond	86	1,166.37	1,163	0
<b>TOTAL</b>			<b>123</b>	<b>4,816.93</b>	<b>3,738</b>	<b>2,178</b>

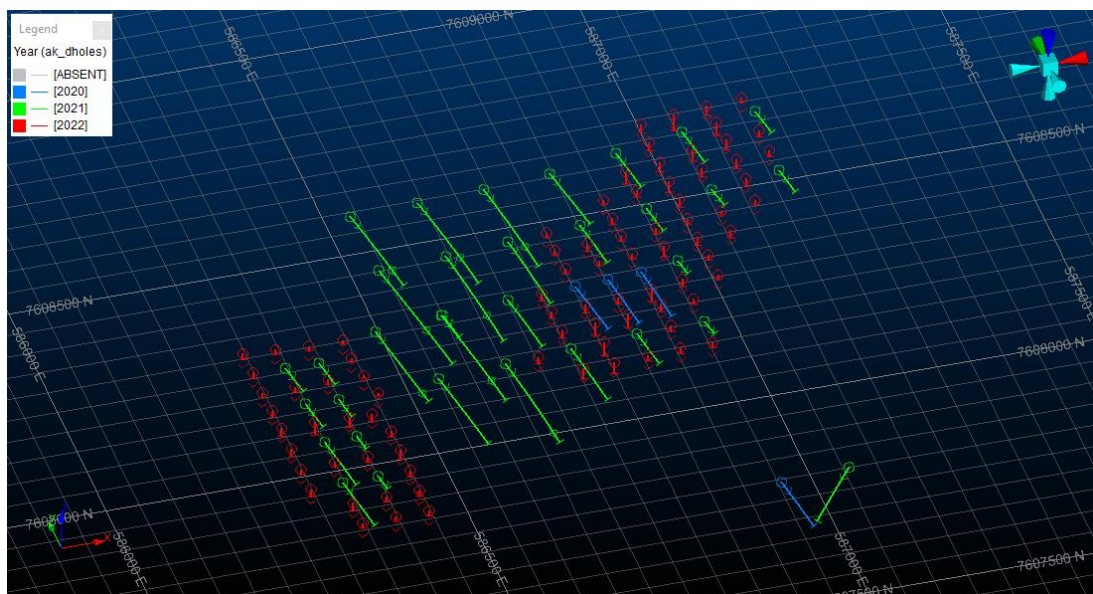
\*DTT: Davis Tube Samples

### 11.3.1.3 Database Processing

The individual exploration database files were imported into Datamine Studio RM. Separate desurveyed drillhole files were created for each of the sample types and exploration campaigns and these individual databases were then combined to form a single composite database containing all data available for the deposit. Verification was carried out during data import and during the desurveying process to ensure that no duplicate or overlapping samples were included in the final database. QA/QC samples within the sample database were removed before further processing.

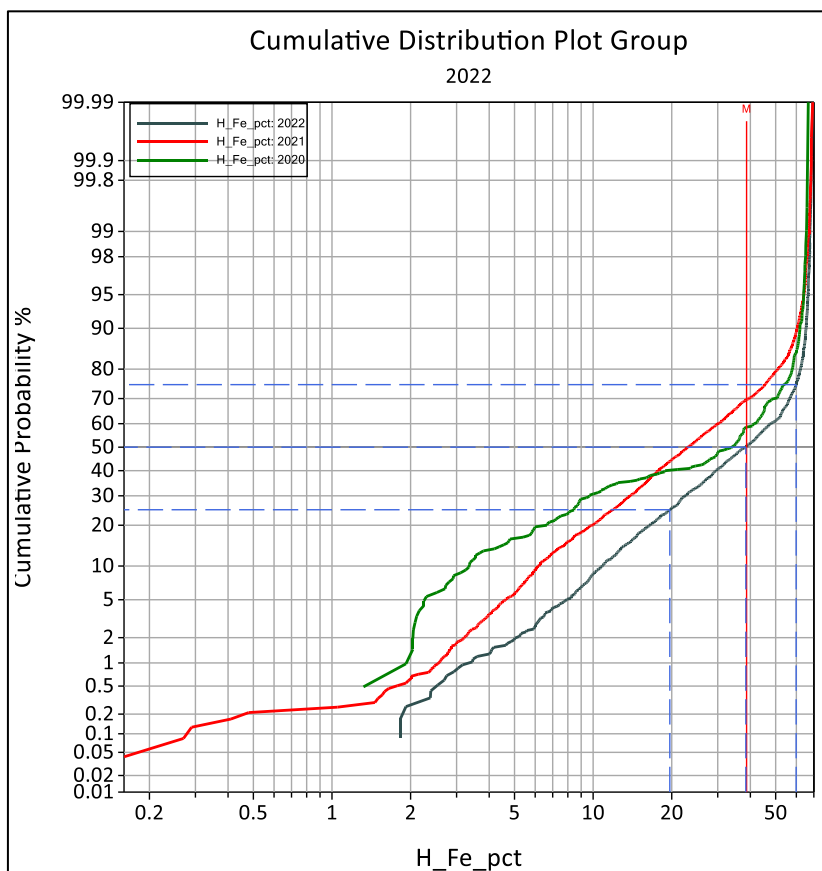
Collar locations were checked against the current topographic surface and were found to be generally consistent with these. Deviation of downhole surveys was checked to ensure that no significant deviations were evident. Validation and verification during data import is outlined in Section 9. The locations of the desurveyed drillholes are shown in Figure 11.1.

For personal use only



**Figure 11.1: Isometric View of Drillholes Coloured by Drilling Year**

The Fe grades of the different exploration programmes were reviewed using log-probability plots as shown in Figure 11.2.



**Figure 11.2: Sample Distribution (Fe) by Drill Programme at Bekisopa South**

Generally, the various drilling campaigns are spatially interspersed. Drilling in 2020 and 2021 consisted of deeper inclined drillholes where-as the 2022 infill drilling focused on shallow (<30m) high-grade DSO mineralisation and accounts for the difference in the Fe population statistics.

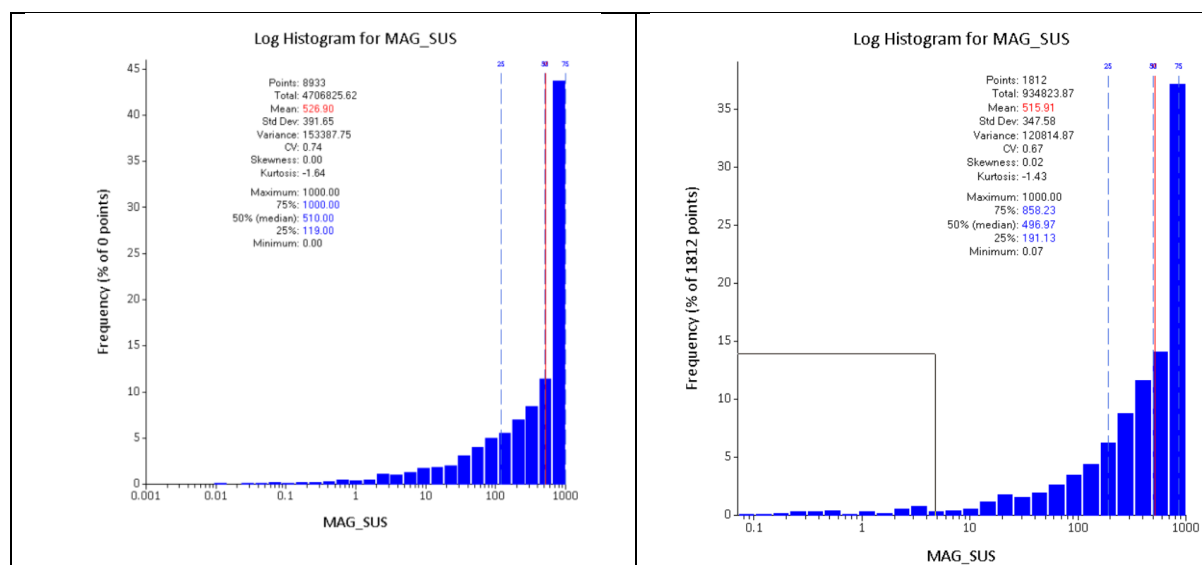
Two twinholes (BEKD043A and BEKD119A) are present in the database. These were included for geological modelling and statistical analysis but were removed from the database prior to grade estimation to prevent spatial bias.

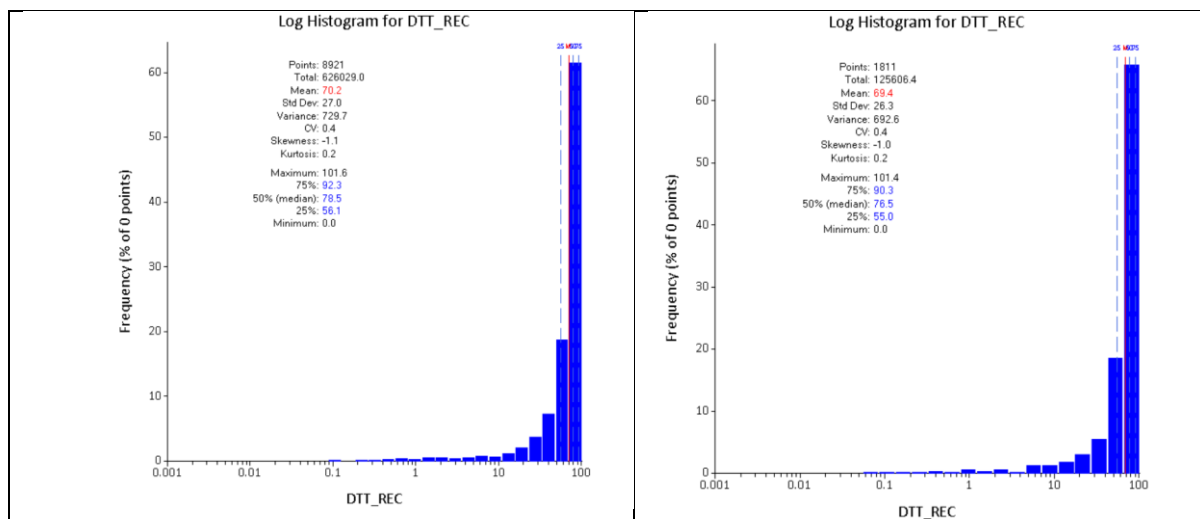
WAI notes that an upper assay limit of 5.0001% is present for sulphur values in the database and recommends that these assays should be re-submitted for analysis using a higher limit before sulphur is included for grade estimation.

### 11.3.2 Magnetic Susceptibility and Davis Tube Recovery

A total of 2,178 DTT recovery grades were available at Bekisopa South for this MRE. Table 11.3 shows the statistics of these results by DENSDOM which consists of a grouping based on Mineralised Zone (MINDOM) and oxidation state (OXIDE).

Magnetic susceptibility readings were taken every 25cm downhole for every drillhole at Bekisopa South, Table 11.4 shows the statistics of these results by DENSDOM. To correlate Magnetic susceptibility values and DTT sample intervals, both datasets were brought into Studio RM and composited to achieve equal intervals. Statistical comparison of the datasets before and after compositing are shown in Figure 11.3. The compositing process has had little impact on the mean and variance (CV) values.





**Figure 11.3: Log Histograms Comparing Statistics Pre-Composited Magnetic Susceptibility (top left) and DTT (bottom left), and Post-Composited Magnetic Susceptibility (top right) and DTT (bottom left)**

FIELD	DENSDOM	NRECORDS	NSAMPLES	NMISVALS	MINIMUM	MAXIMUM	MEAN
DTT_Fe_R	310	344	60	284	6.0	90.9	52.2
DTT_Fe_R	320	474	404	70	0.8	99.8	74.2
DTT_Fe_R	330	613	607	6	1.8	101.0	84.8
DTT_Fe_R	410	1	1	0	59.3	59.3	59.3
DTT_Fe_R	420	61	59	2	13.6	91.2	72.3
DTT_Fe_R	430	-	-	-	-	-	-
DTT_Fe_R	510	33	6	27	53.9	83.1	67.8
DTT_Fe_R	610	6	1	5	62.5	62.5	62.5
DTT_Fe_R	710	1	0	1	-	-	-
DTT_Fe_R	720	20	15	5	20.3	97.2	74.2

FIELD	DENSDOM	NRECORDS	NSAMPLES	NMISVALS	MINIMUM	MAXIMUM	MEAN
Mags_DIS	310	344	60	284	2.3	80.4	30.0
Mags_DIS	320	474	404	70	0.1	93.6	38.2
Mags_DIS	330	613	607	6	0.3	94.9	53.7
Mags_DIS	410	1	1	0	31.1	31.1	31.1
Mags_DIS	420	61	59	2	2.3	62.3	25.9
Mags_DIS	430	-	-	-	-	-	-
Mags_DIS	510	33	6	27	23.5	55.5	38.9
Mags_DIS	610	6	1	5	38.9	38.9	38.9
Mags_DIS	710	1	0	1	-	-	-
Mags_DIS	720	20	15	5	5.1	78.4	39.9

DTT values of greater than 100% were subsequently re-set by WAI to 100%. Magnetic susceptibility and DTT were then estimated into the block model from the drillhole composites using hard boundaries for the mineralised domains and weathering domains (DENS DOM key field) and using the same estimation parameters used were the same as detailed in Section 11.9.1.

### 11.3.3 Cut-Off Grade Analysis

Fe grades in the exploration database were reviewed using histogram and log-probability plots (Figure 11.4) and contiguous length analysis (Figure 11.5) to determine a 'natural' cut-off grade to define the mineralised zones. Based on this, mineralisation envelopes were defined by creating 3D wireframes using a nominal cut-off grades of 58% Fe for DSO and 25% Fe for non-DSO material.

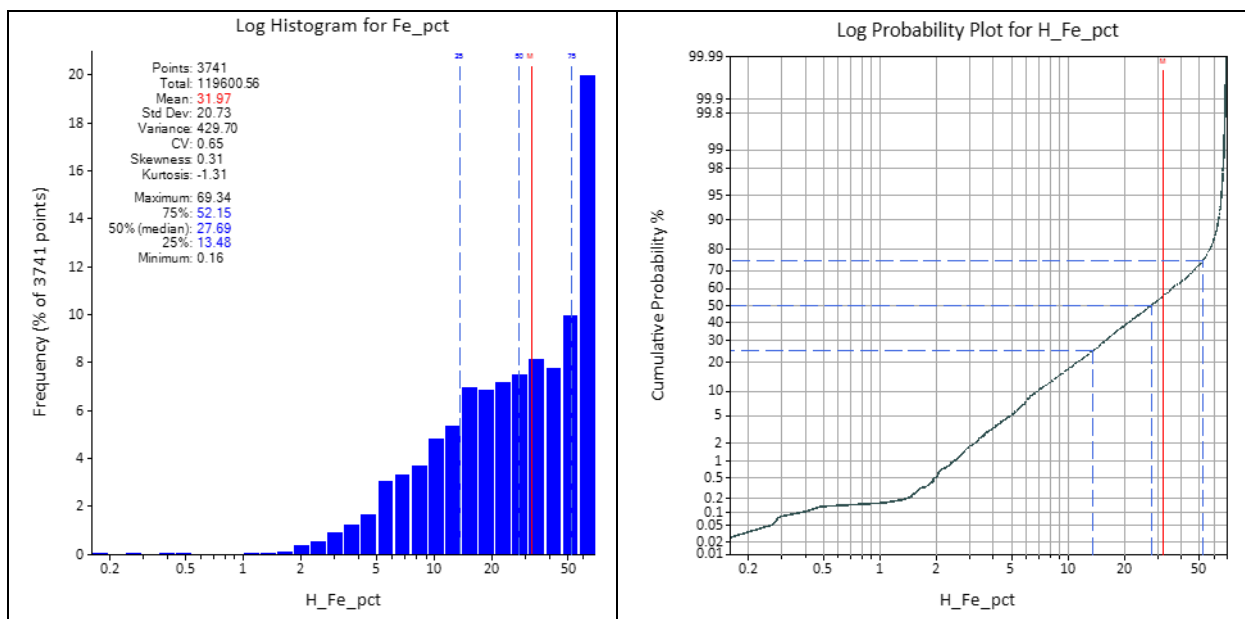


Figure 11.4: Log Histogram and Log Probability Plot for Bekisopa South Fe Assays

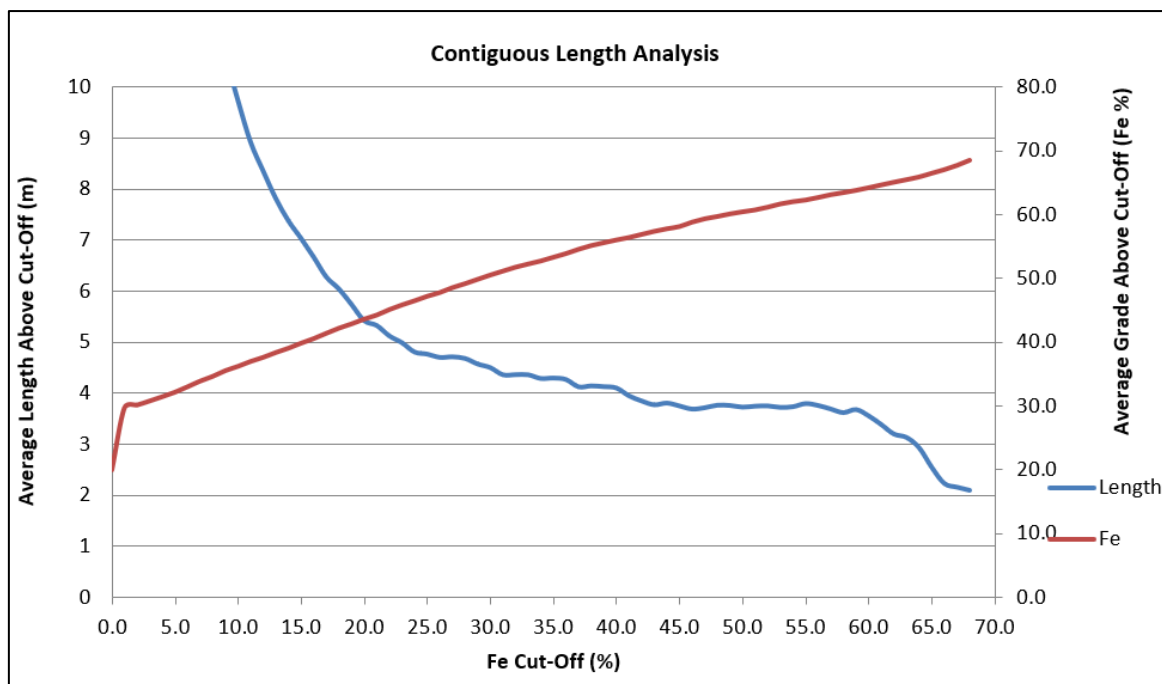


Figure 11.5: Contiguous Length Analysis of the DSO Fe Grades

#### 11.3.4 Topography

A Digital Terrain Model (DTM) representing pre-mining topography was supplied by the Client in dxf format. This data was generated from a Drone survey (see Section 7.4), conducted using PHANTOM 4 Pro type drones in 2021 by FUTURMAP contractors, and a pair of LEICA System 1200 dual frequency GPS. An accuracy of 10mm horizontal and 20mm vertical is quoted.

#### 11.3.5 Domaining

##### 11.3.5.1 Introduction

Mineralisation wireframes were developed using Datamine modelling software to create near surface, high-grade DSO domains for the east and west zones (MINDOMs 1 and 2), and deeper mineralised wireframes (Green Steel) for the east (MINDOM 3). Several low-grade wireframes (MINDOMs 4, 5, 6 and 7) were also generated to capture zones of mineralisation outside of the main DSO and Green Steel trends. Smaller wireframes of barren zones (MINDOMs 101 and 102) were also created. Barren mineralisation outside of the mineralised zones was assigned as MINDOM 103.

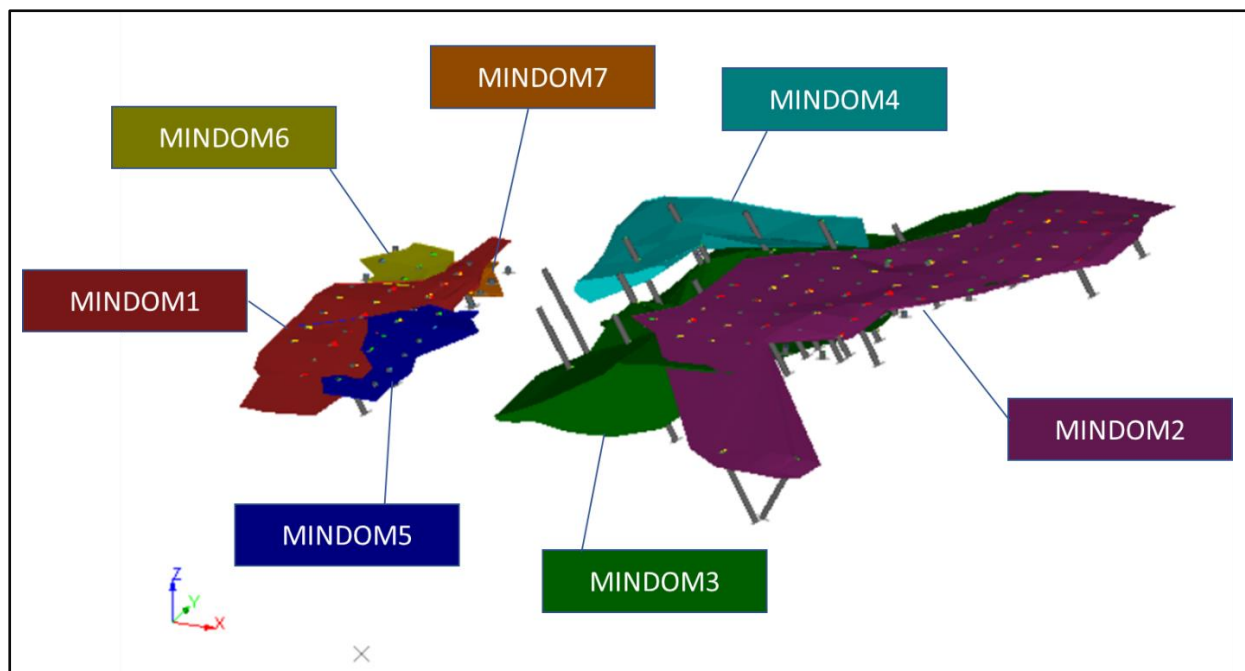


Figure 11.6: Bekisopa South Mineralisation Domains

Table 11.5: Bekisopa South Mineralisation Domains	
MINDOM	Description
1	DSO West
2	DSO East
3	Green Steel Zone
4	Low Grade (East)
5	Low Grade (West)
6	Low Grade (West)
7	Low Grade (West)
101	Internal Waste
102	Internal Waste
103	Waste

### 11.3.5.2 Geological Domaining

DSO material was defined based on a cut-off grade of 58% Fe and this material is predominantly hosted in regolith, although minor amounts of less weathered material were also captured within these wireframe zones.

For the Green Steel zone, a 25% Fe cut-off grade was used. Due to the varied lithological nature of the Fe mineralisation within the interbedded metamorphic units, modelling was completed using assay values only. Additional drilling will be required for detailed geological modelling of this zone to be undertaken.

Occasional intersections below cut-off grade were allowed for the purposes of preserving continuity of the domains along strike or down dip.

Several low-grade wireframes were also generated to capture zones of mineralisation outside of the main DSO and Green Steel trends.

Two 'Barren Zones' were modelled based on the Fe grade data, one within the Green Steel and the other within the Western DSO wireframe. These areas contain anomalously low Fe grades and were therefore domained separately.

### Comparison to Previous Interpretation

A maiden MRE for the Bekisopa Iron Project (North, Central and South) was completed by H&S in April 2022 (Table 1.1). WAI has updated the interpretation of the Fe mineralisation to include the drilling by Akora during 2022 and applied a wireframe cut-off at 25% Fe to define the mineralisation of the Green Steel zone. A comparison of the H&S interpretation and the updated WAI interpretation is shown in Figure 11.7 and Figure 11.8.

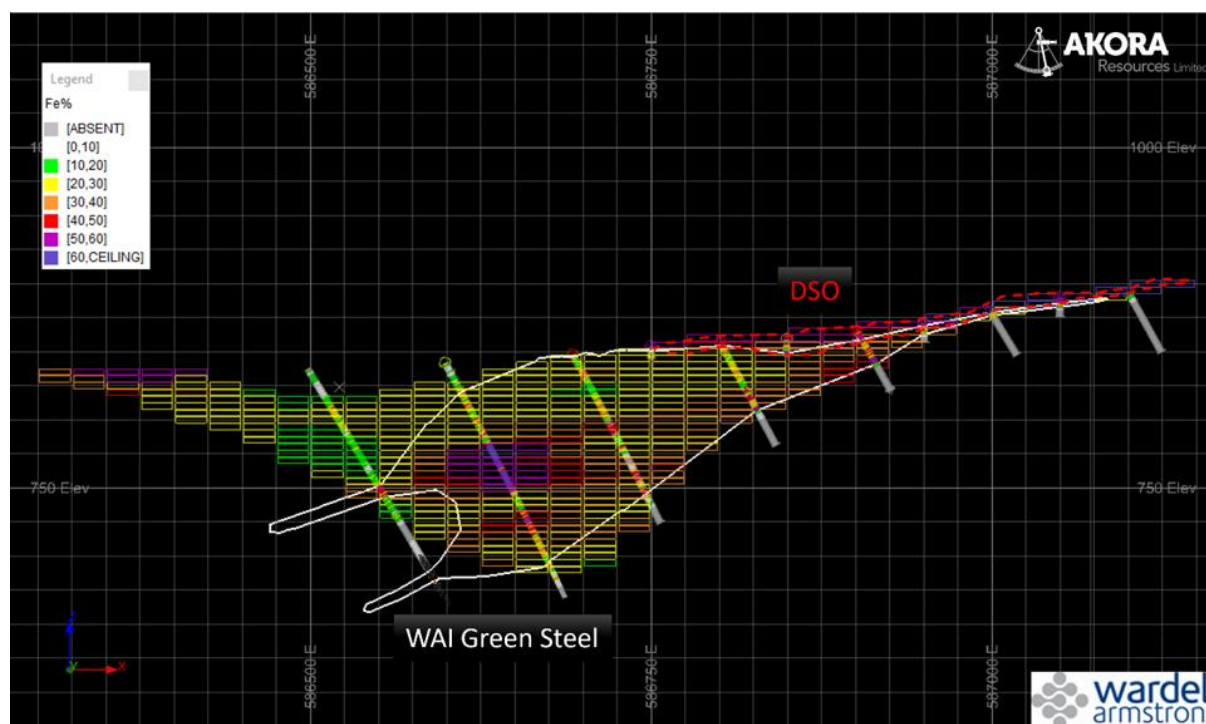


Figure 11.7: Previous H&S Block Model Overlain by Updated WAI Wireframe Interpretation

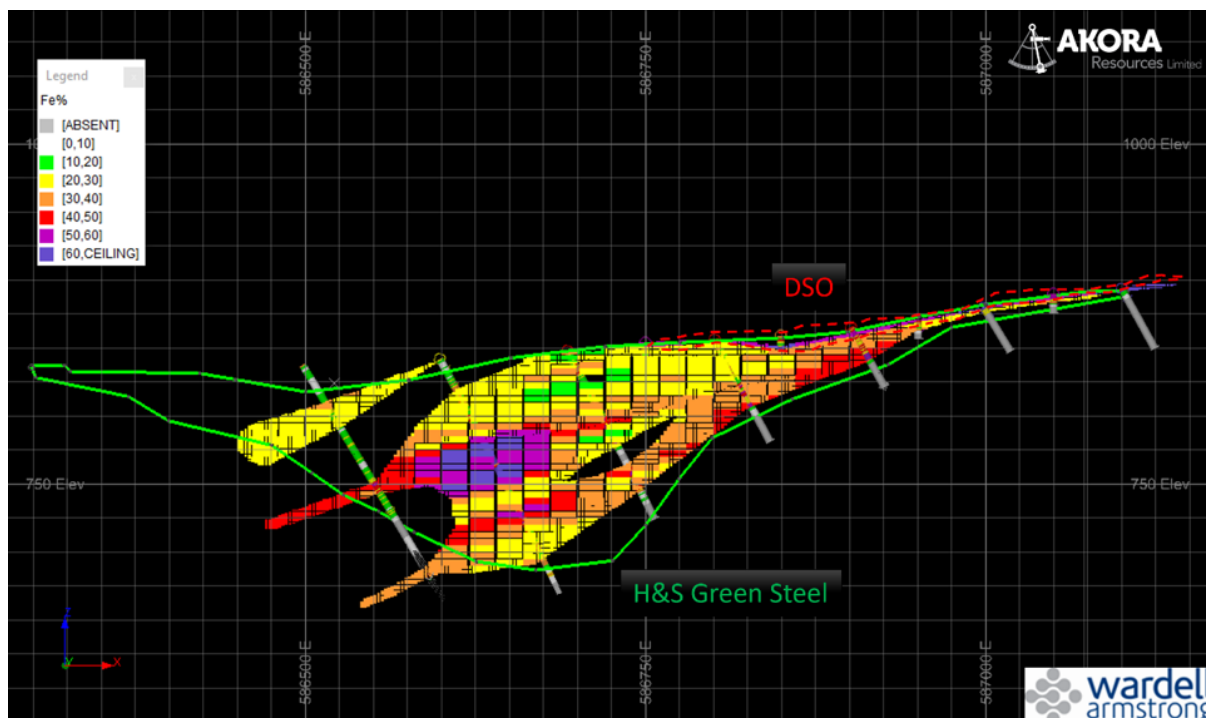


Figure 11.8: Updated WAI Block Model Overlain by Previous H&S Wireframe Interpretation

### 11.3.5.3 Oxidation Domains

Surfaces representing the weathering profiles at Bekisopa South were generated based on the drillhole logging weathering codes and were modelled using datamine software as follows:

- CW (Completely weathered) & (Highly weathered)
- MW (Moderately weathered); and
- SW (Slightly weathered) & FR (Fresh)

Table 11.6: Weathering and Density Domain Codes

Mineralised Domain (MINDOM Code)	Weathering	Weathering Code (OXIDE Code)	Density Domain (DENSDOM Code)
1	HW	10	110
1	MW	20	120
2	HW	10	210
2	MW	20	220
3	HW	10	310
3	MW	20	320
3	SW	30	330
4	HW	10	410
4	MW	20	420
4	SW	30	430
5	HW	10	510
6	HW	10	610
7	HW	10	710
7	MW	20	720
101	HW	10	-
101	MW	20	-

Code	Weathering	Density	Other
101	SW	30	-
102	HW	10	-
102	MW	20	-
103	HW	10	-
103	MW	20	-
103	SW	30	-

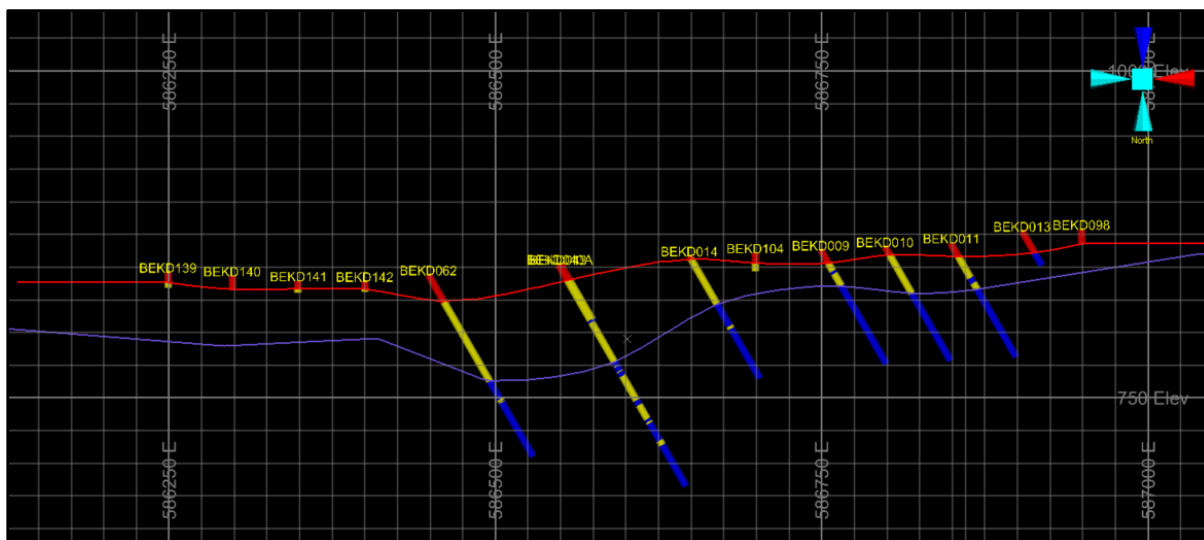


Figure 11.9: Section Showing Weathering Surfaces at Bekisopa South  
Red Surface = Base of Highly Weathered, Purple Surface = Base of Moderately Weathered

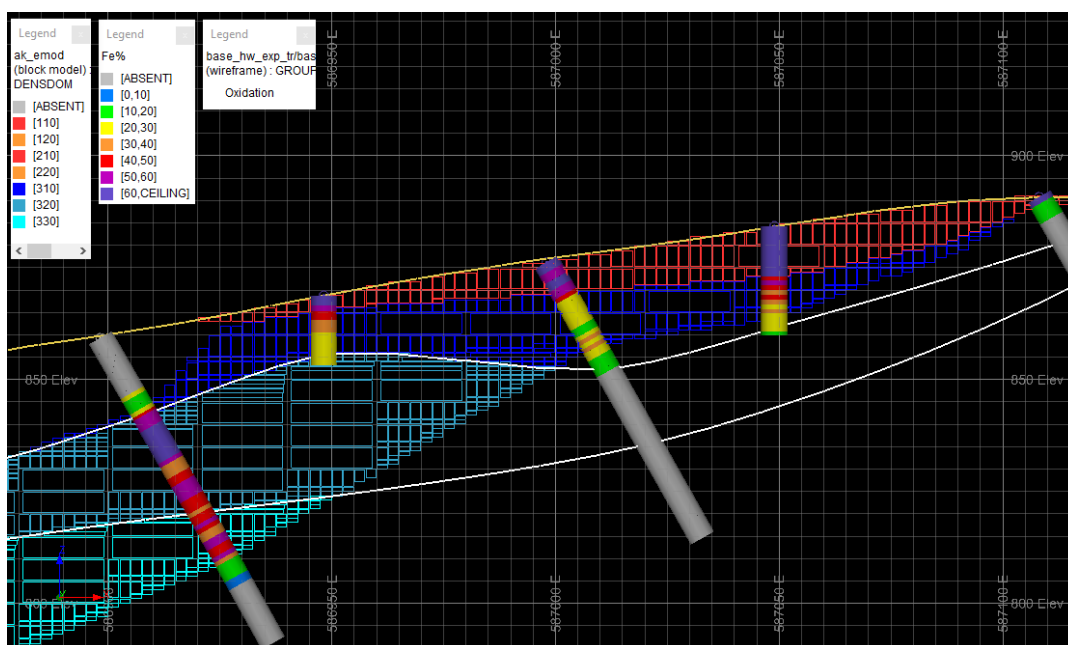


Figure 11.10: Section Showing DENS DOM Code in Block Model, Sub-blocking at MINDOM and Oxidation Boundaries and Drillholes Showing Fe (%)

For personal use only

### 11.3.6 Selected Samples

#### 11.3.6.1 Sample Selection and Keyfields

Samples from the exploration drillholes within the area of interest were selected for further processing. Samples were assigned key field codes based on their location within the individual OZONE and ZONE domains.

#### 11.3.6.2 Summary Statistics

Summary Statistics for each variable by MINDOM are shown in Table 11.7.

FIELD	MINDOM	NSAMPLES	MIN	MAX	MEAN	VARIANCE	STANDDEV	SKEWNESS	CV
FE	1	240	8.42	69.34	58.98	105.16	10.25	-1.93	0.17
FE	2	416	22.66	68.29	60.56	41.33	6.43	-1.94	0.11
FE	3	1702	1.96	67.57	35.21	276.05	16.61	0.10	0.47
FE	4	82	5.56	57.5	21.95	98.35	9.92	0.68	0.45
FE	5	42	7.81	50	27.89	84.57	9.20	0.35	0.33
FE	6	8	26.16	48.3	36.55	49.83	7.06	-0.02	0.19
FE	7	26	3.36	63.63	33.93	363.27	19.06	-0.15	0.56
FE	101	50	2.78	24.45	7.70	15.34	3.92	2.09	0.51
FE	102	14	9.09	59.54	30.06	134.47	11.60	0.79	0.39
FE	103	1158	0.16	64.6	13.21	79.00	8.89	1.71	0.67

### 11.4 Exploratory Data Analysis

#### 11.4.1 Outliers and Top-Cuts

The selected samples were reviewed for each mineralised zone to identify the presence of any anomalously high outlier grades for Fe, SiO<sub>2</sub>, Al<sub>2</sub>O<sub>3</sub>, Mn, P, and TiO<sub>2</sub>. No significant outliers were identified, and no top-cuts were required.

#### 11.4.2 Compositing

Compositing of drillhole samples is carried out to ensure that a consistent level of support is achieved for estimation, and any bias effect due to varying sample length is removed. To ensure that the underlying characteristics of the data are retained, a composite length of 1m was chosen and best reflected the original average sample length (Figure 11.11). An algorithm used during the compositing process forces all samples to be included in the final composite file by allowing slight adjustments to the composite length, whilst keeping as close as possible to the ideal 1m composite length.

For personal use only

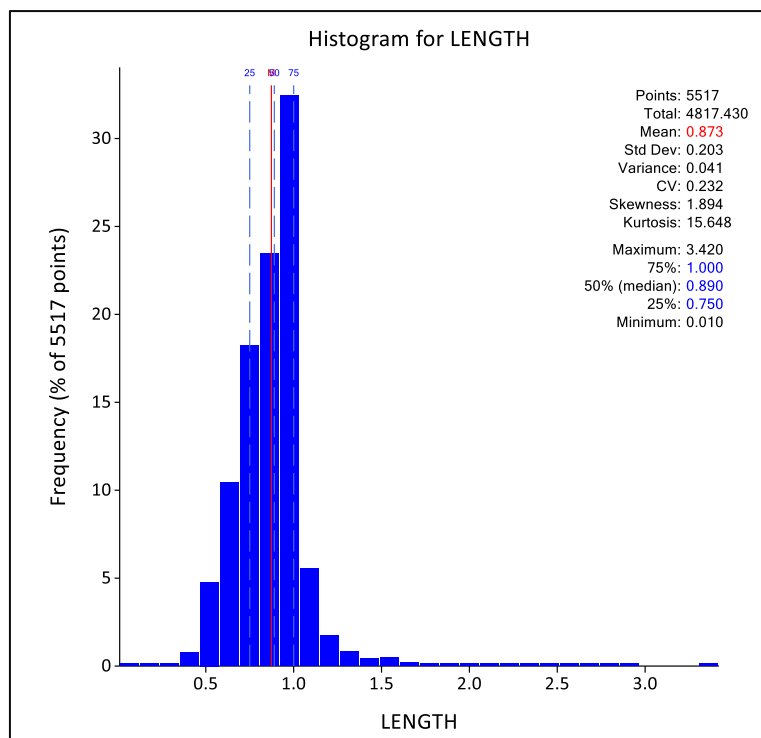


Figure 11.11: Histogram of Sample Lengths

### 11.4.3 Summary Statistics of Final Composite Samples

The statistics of composited Fe grades in the final composite file for further processing is shown in Table 11.8 based on the MINDOM code.

Table 11.8: Summary Statistics for Fe (%) by MINDOM of Composites									
FIELD	MINDOM	NSAMPLES	MIN	MAX	MEAN	VARIANCE	STANDDEV	SKEWNESS	CV
FE	1	211	27.48	69.04	59.44	68.48	8.28	-1.42	0.14
FE	2	384	30.87	68.01	60.68	32.23	5.68	-1.64	0.09
FE	3	1428	2.49	66.80	35.40	235.61	15.35	0.16	0.43
FE	4	62	6.05	48.26	22.36	69.37	8.33	0.34	0.37
FE	5	33	8.71	47.05	28.27	79.30	8.91	0.14	0.31
FE	6	6	28.41	42.20	37.67	18.68	4.32	-1.43	0.11
FE	7	21	6.05	59.24	33.64	272.40	16.50	-0.07	0.49
FE	101	46	2.81	24.28	7.58	14.59	3.82	2.18	0.50
FE	102	12	19.35	45.90	30.43	64.42	8.03	0.70	0.26
FE	103	1016	0.18	52.82	12.70	61.18	7.82	1.37	0.62

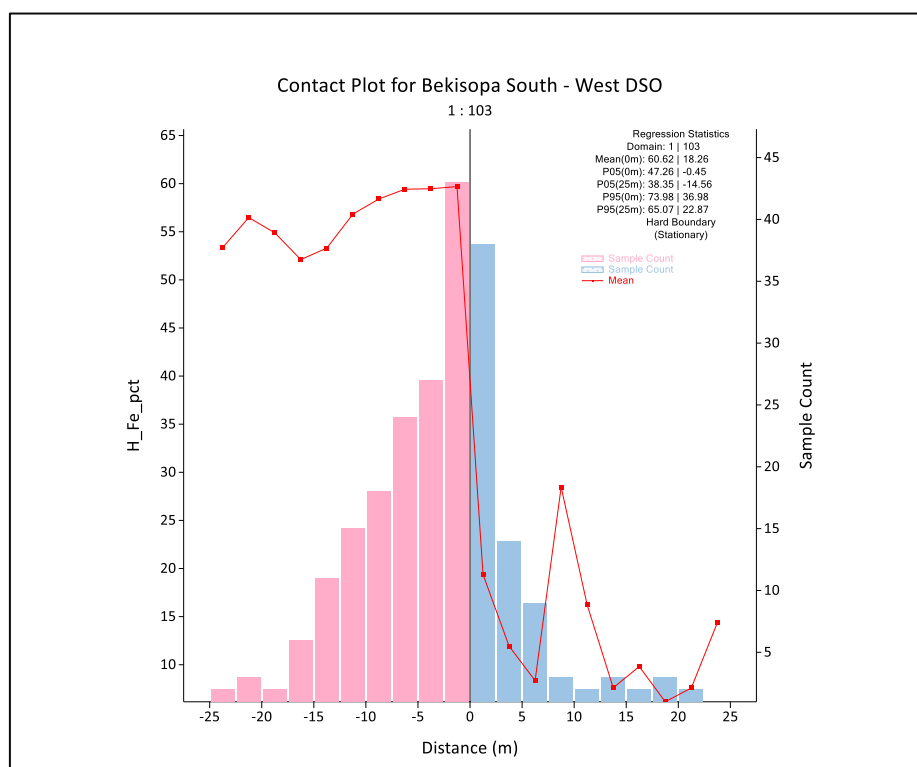
### 11.5 Boundary/Contact Analysis

Hard boundaries are evident between the background domain and the wireframed mineralised domains. Contact plots demonstrating this are shown in Figure 11.12 to Figure 11.14 for the combined

sample set. Contact plots measures the rate of grade change across the contact between two domains, with the red line on each plot showing the mean of Fe values across each domain. Irregularity to the mean can be seen within the domain as distance to the boundary increases – and the number of points reduces. The same trend can be seen as distance away from the contact increases to the outside, typically due to Fe grades not encapsulated within the domain. Plots for Fe and domains show a sharp step change consistent with hard boundary conditions.

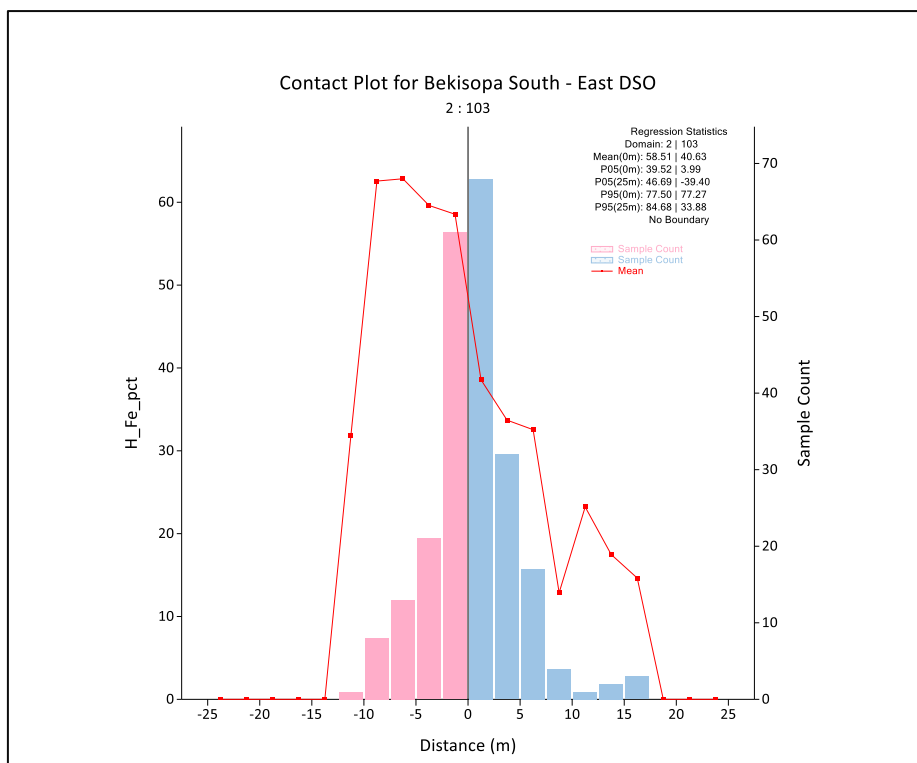
WAI elected to use hard boundaries for sample selection and use of those samples during grade estimation due to the distinct and often discontinuous nature of the individual mineralised domains. A complex relationship exists between the Fe grades and oxidation boundaries, which requires further study. Oxidation boundaries were therefore treated as soft boundaries during grade estimation but as hard boundaries for density estimation.

For personal use only

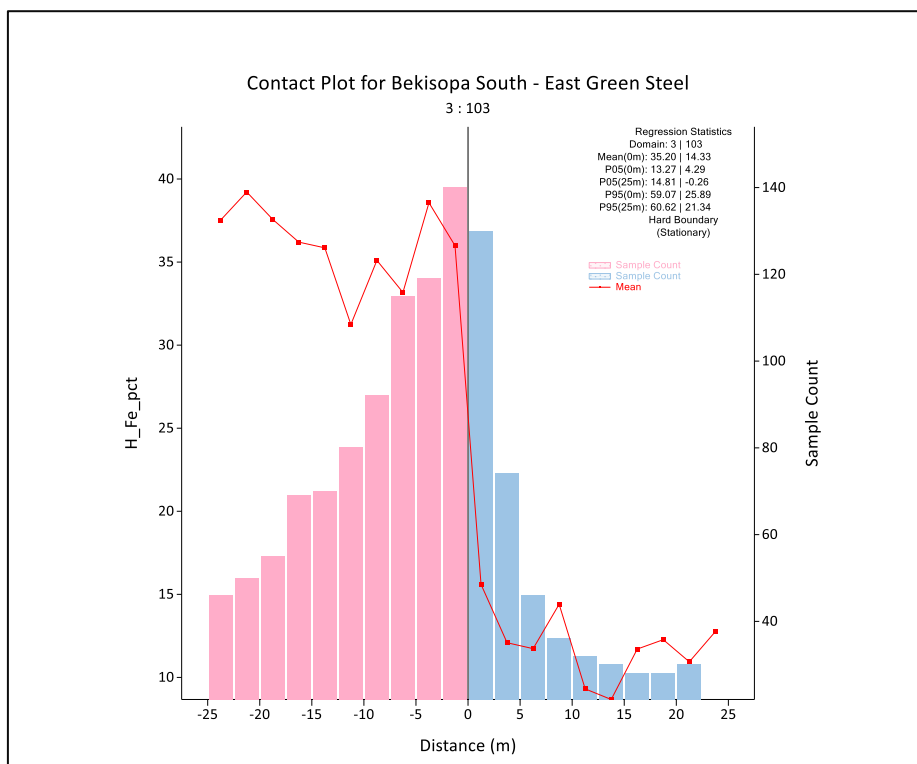


**Figure 11.12: Contact Plot for Bekisopa South - West DSO. Red = Inside DSO wireframe  
Blue = Outside DSO wireframe**

For personal use only



**Figure 11.13: Contact Plot for Bekisopa South - East DSO. Red = Inside DSO wireframe  
Blue = Outside DSO wireframe**



**Figure 11.14: Contact Plot for Bekisopa South - East Green Steel  
Red = Inside Green Steel wireframe, Blue = Outside DSO wireframe**

### 11.6 Variography

Variography was undertaken by WAI using Snowden Supervisor software. Experimental variograms were generated based on the orientation of the mineralisation defined by continuity analysis. Directional and downhole variograms for Fe, SiO<sub>2</sub>, Al<sub>2</sub>O<sub>3</sub>, Mn, P, and TiO<sub>2</sub> were attempted from the 1m composites of each MINDOM based on a normal score transformation. Examples of experimental variograms for Fe (%) in MINDOMs 1, 2 and 3 are shown in Figure 11.15, Figure 11.16 and Figure 11.17. Experimental variograms for Fe, SiO<sub>2</sub>, Al<sub>2</sub>O<sub>3</sub>, Mn, P, and TiO<sub>2</sub> for all mineralised zones are contained in Appendix 5.

The experimental variograms were used by WAI to provide an indication of potential ranges to derive suitable search parameters for grade estimation, however, were not considered by WAI to be of sufficient quality to be used for grade estimation by kriging.

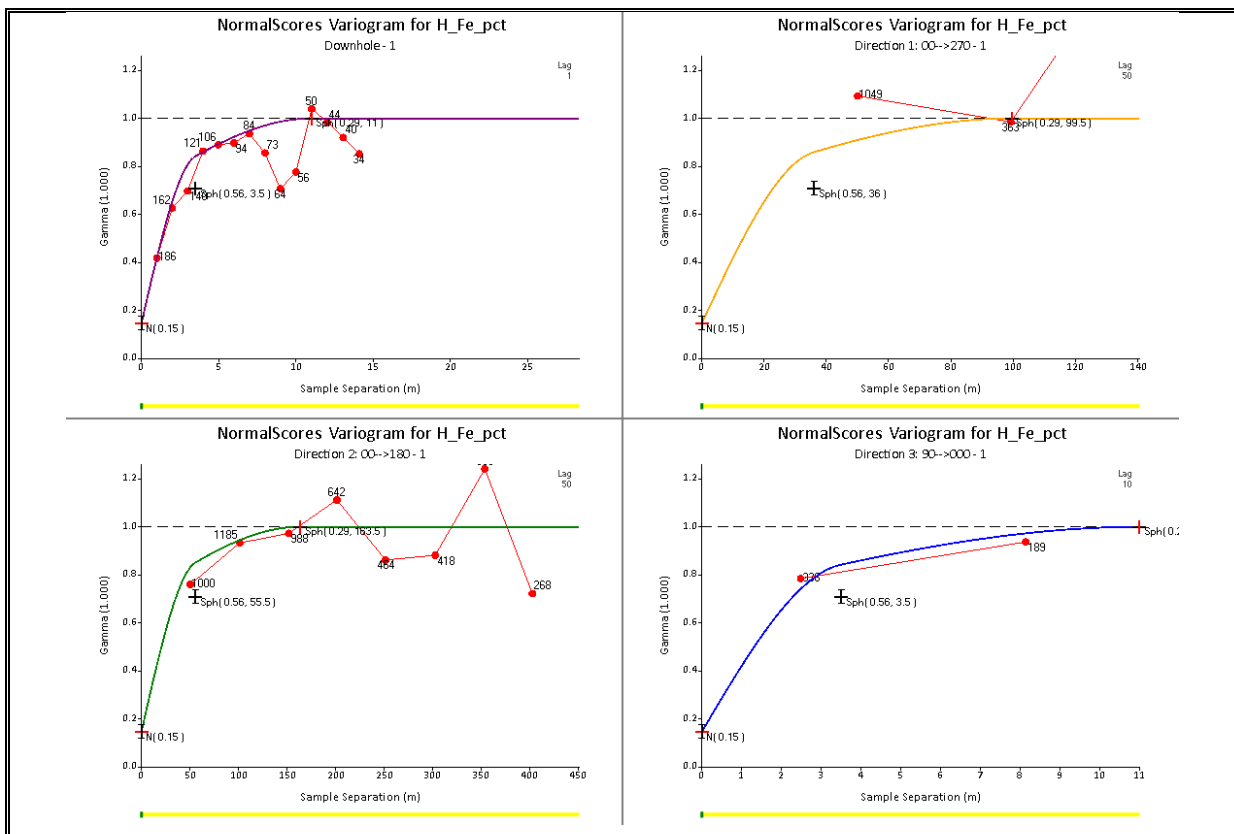


Figure 11.15: Experimental Variograms Fe (%) for MINDOM 1

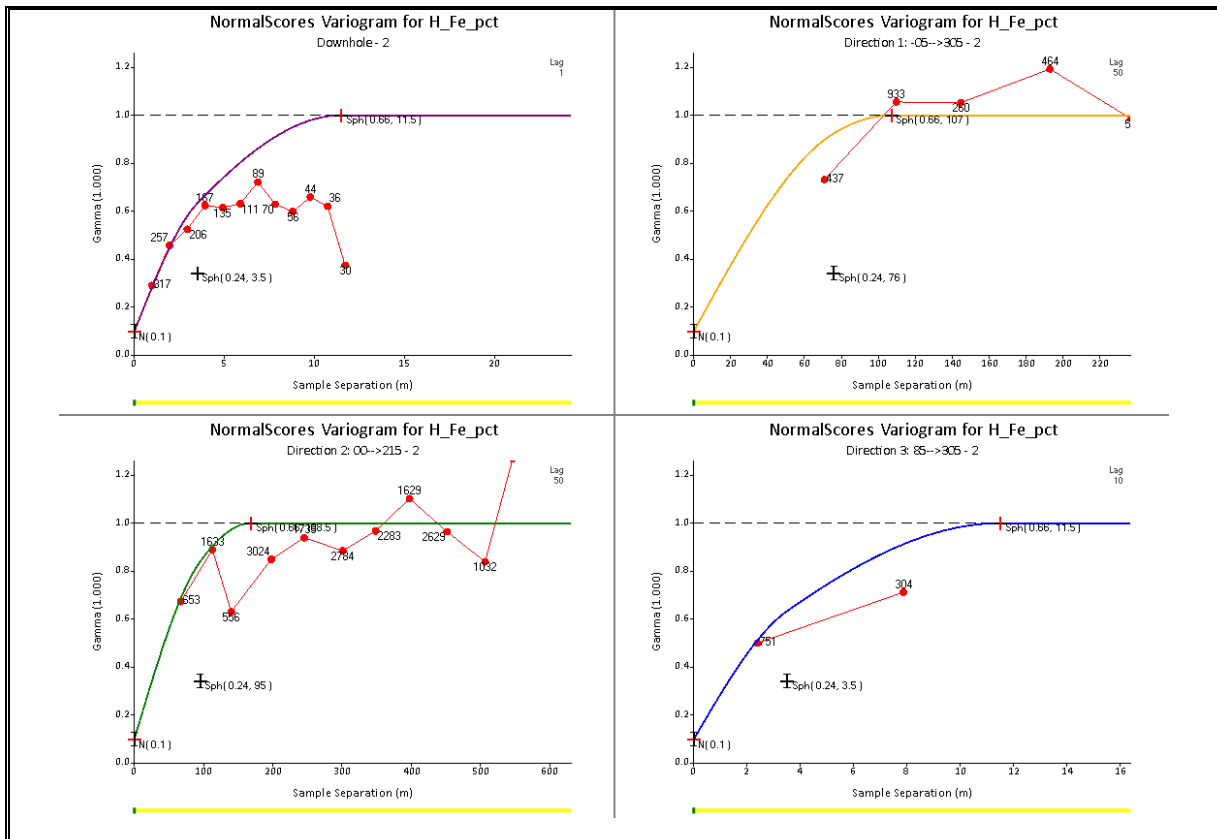


Figure 11.16: Experimental Variograms Fe (%) for MINDOM 2

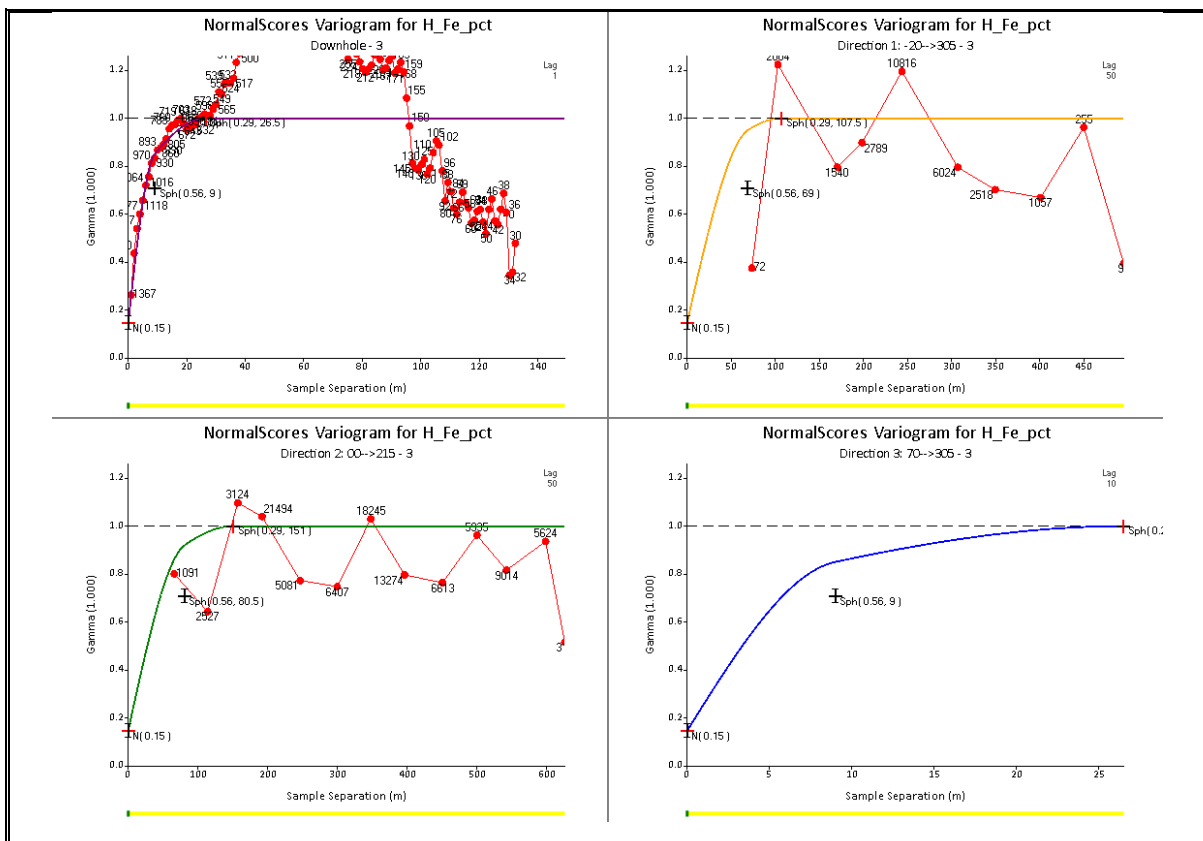


Figure 11.17: Experimental Variograms Fe (%) for MINDOM 3

For personal use only

## 11.7 Block Modelling

A block model defining the mineralised zones was constructed using the domain wireframes and coded by these principal domains. A model prototype with a parent cell size of 20m x 20m x 5m (X, Y, Z) was used for this initial volumetric model. Sub-cell splitting was enabled down to a minimum cell size of 2.5m x 2.5m x 1m. Blocks were selected below the topographical surface and the model coded using the base of highly weathered and moderately weathered wireframes. A summary of the block model prototype is shown in Table 11.9.

Property	Direction	Dimensions (m)
Model Origin	X	586000
	Y	7607200
	Z	500
Parent Cell Size	X	20
	Y	20
	Z	5
No. of Cells	X	70
	Y	90
	Z	90

## 11.8 Density

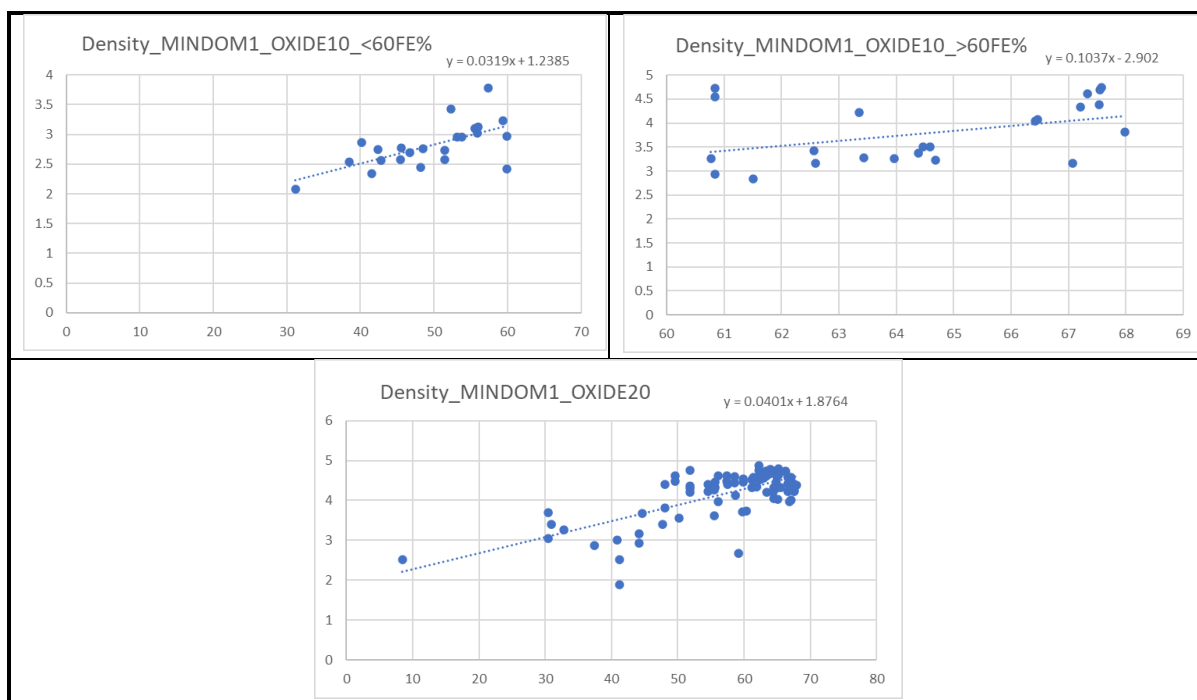
A total of 3,599 density measurements have been taken from samples at Bekisopa South, measured by either the Archimedes principle using a density scale (1,448 in total) in competent rock or by using a calliper vernier (2,151 in total) in incompetent/weathered rock. Density data was subdivided by WAI into weathering sub-domains, within the mineralisation wireframes.

Regression formula using Fe grades and density data were derived by WAI to assign density values in the drillholes. The regression equations calculated by WAI are summarised in Table 11.10, and shown graphically in Figure 11.18 to Figure 11.21. The regressed density values were then estimated into the block model from the drillhole composites using hard boundaries for the mineralised domains and weathering domains (DENSDOM key field) and using the same estimation parameters as detailed in Section 11.9.1.

MINDOM	Weathering Horizon	Fe_Pct (%)	Regression Equation	Comment
1	HW	H_Fe_pct<60	$y = 0.0319xFe + 1.2385$	-
	MW	H_Fe_pct>60	$y = 0.1037xFe - 2.902$	-
1	HW		$y = 0.0401xFe + 1.8764$	-
2	HW	H_Fe_pct<60	$y = 0.0207xFe + 1.5757$	-
	MW	H_Fe_pct>60	$y = 0.2309xFe - 11.34$	-
2	MW		$y = 0.0194xFe + 2.1288$	-
3	SW		$y = 0.0182xFe + 1.6152$	-
3	HW		$y = 0.0327xFe + 2.2157$	-
3	MW		$y = 0.0322xFe + 2.6416$	-

**Table 11.10: Density Samples and Regression Equations by MINDOM and Weathering Horizon**

4	SW		$y = 0.0211xFe + 1.3779$	Regression for MINDOM 5 used as no density samples available
4	MW		$y = 0.0321xFe + 2.5819$	
4	HW		$y = 0.0321xFe + 2.5819$	Regression for MINDOM 4 (MW) used as no density samples available.
5	HW		$y = 0.0211xFe + 1.3779$	
6	MW		$y = 0.0211xFe + 1.3779$	Regression for MINDOM 5 used as limited number of density samples available.
7	HW		$y = 0.0211xFe + 1.3779$	Regression for MINDOM 5 used as no density samples available
7	MW		$y = 0.0389xFe + 2.235$	
101	HW		1.80	Average density of zone
101	MW		2.43	Average density of zone
101	SW		2.79	Average density of zone
102	HW		2.37	Average density of zone
102	MW		2.44	Average density of zone
103	HW		1.89	Average density of zone
103	MW		2.62	Average density of zone
103	SW		2.93	Average density of zone



**Figure 11.18: Density Regression Analysis for MINDOM 1 by OXIDE Domain**

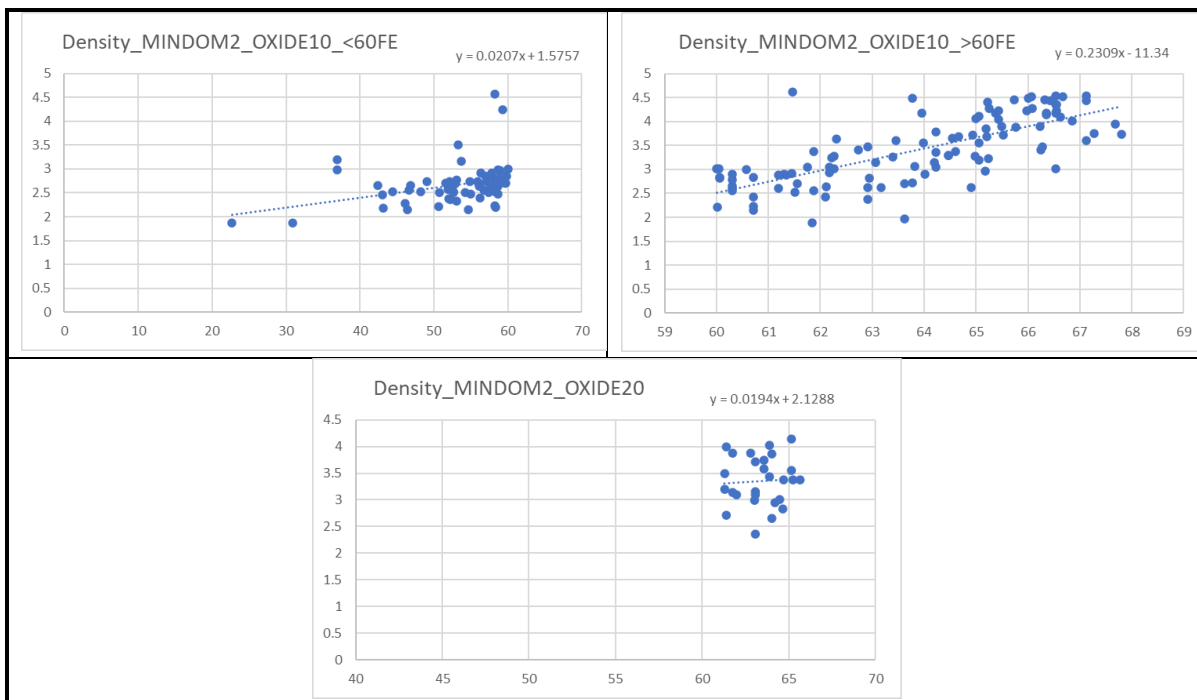


Figure 11.19: Density Regression Analysis for MINDOM 2 by OXIDE Domain

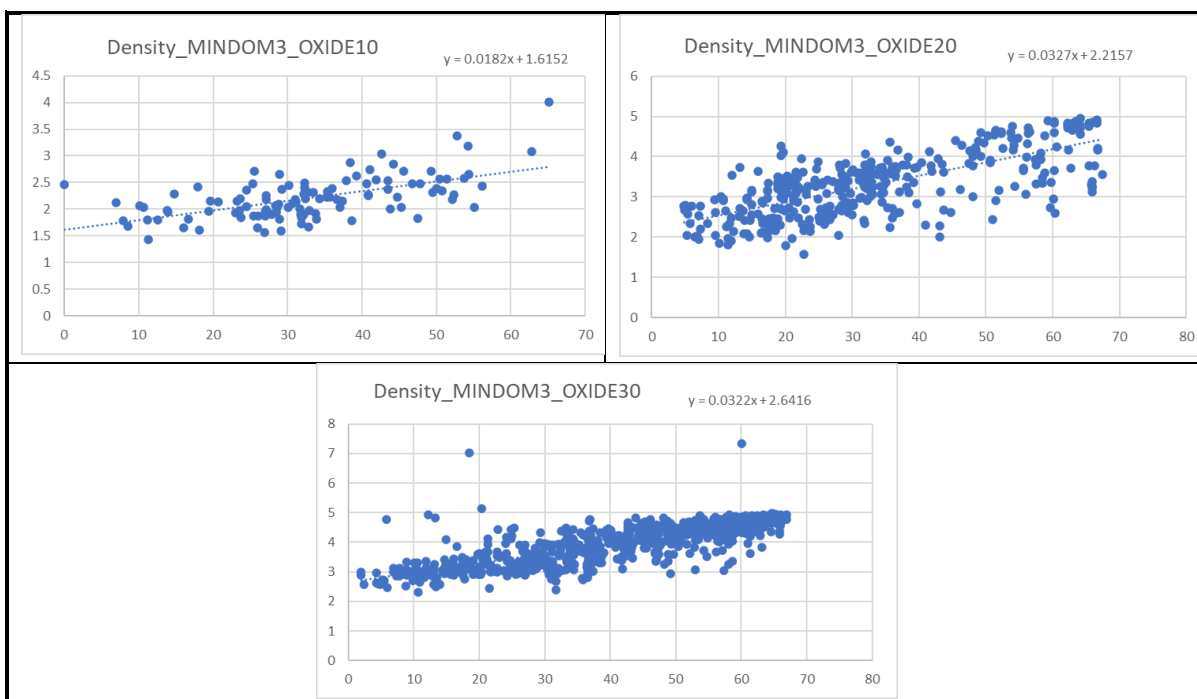


Figure 11.20: Density Regression Analysis for MINDOM 3 by OXIDE Domain

For personal use only

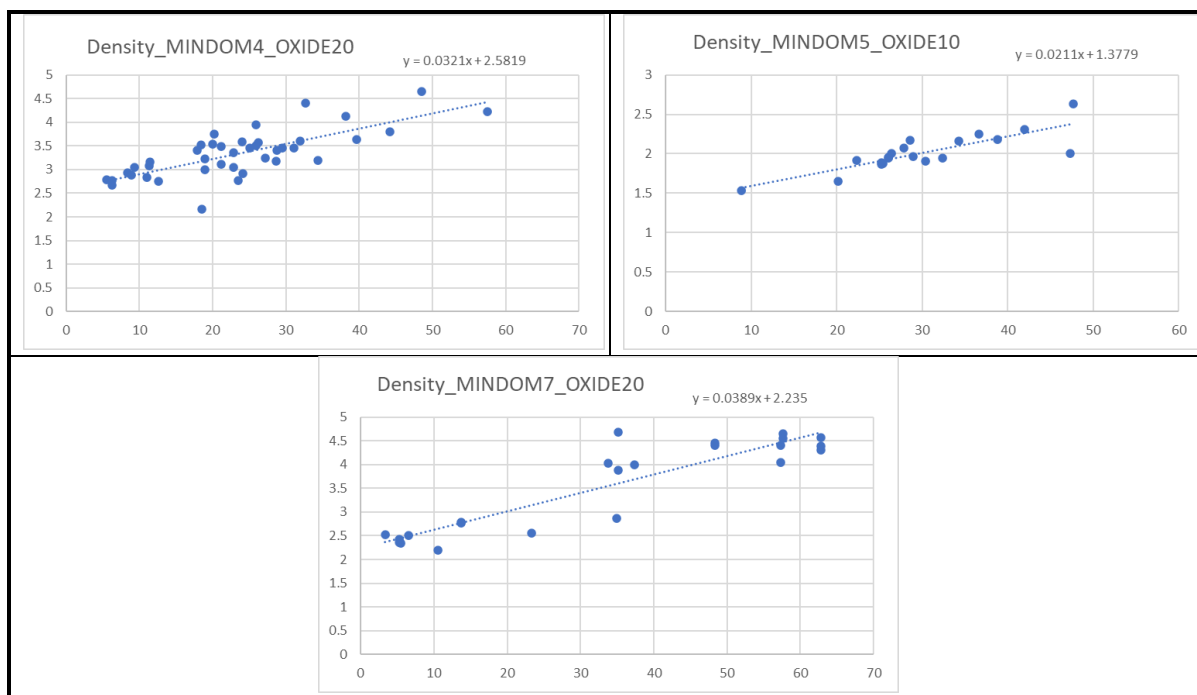


Figure 11.21: Density Regression Analysis for MINDOMs 4, 5 and 7 by OXIDE Domain

### 11.9 Grade Estimation

Grade estimation was performed only on mineralised material defined within each MINDOM domain. The domains were treated as hard boundaries and composites from an adjacent domain could not be used in the grade estimation of another domain. Inverse distance weighting to power 3 (IDW<sup>3</sup>) and nearest neighbour (NN) estimations were undertaken.

#### Grade Estimation Plan

Grade estimation was undertaken for Fe, SiO<sub>2</sub>, Al<sub>2</sub>O<sub>3</sub>, Mn, P, and TiO<sub>2</sub>. The estimates were run in a three-pass plan, the second and third passes using progressively larger search radii to enable the estimation of blocks unestimated on the previous pass. The search parameters were based on the variography and general drillhole spacings. The third search was used to ensure that all blocks contained within the domains were estimated. Twinholes BEKD043A and BEKD119A were excluded from the grade estimation.

Grade estimation was carried out using a parent block size of 20m x 20m x 5m. Sub-cells received the same grade as the parent cell. Block discretisation was set to 2 x 2 x 5 to estimate block grades. Search ellipse orientations were consistent with the directions identified in the variography. A summary of the grade estimation plan is shown in Table 11.11.

MINDOM	Search	Search Distance (m)			Composites		Drillholes
		Down Dip	Along Strike	Across Strike	Minimum	Maximum	Minimum
1	1 <sup>st</sup>	50	75	10	11	22	2
	2 <sup>nd</sup>	100	150	20	11	22	2
	3 <sup>rd</sup>	150	225	30	2	20	1
2	1 <sup>st</sup>	50	75	10	11	22	2
	2 <sup>nd</sup>	100	150	20	11	22	2
	3 <sup>rd</sup>	150	225	30	2	20	1
3	1 <sup>st</sup>	50	75	15	11	22	2
	2 <sup>nd</sup>	100	150	30	11	22	2
	3 <sup>rd</sup>	150	225	45	2	20	1

Notes:  
MINDOM 1 orientation – down dip: east-west; along strike: north-south;  
MINDOM 2 orientation – down dip: -5 degree dip to 305 degrees azimuth; along strike: 35 degrees azimuth;  
MINDOM 2 orientation – down dip: -20 degree dip to 305 degrees azimuth; along strike: 35 degrees azimuth;  
(MINDOM 1 search used for MINDOMS 5, 6 and 7)  
(MINDOM 2 search used for MINDOM 4)  
Maxkey of 10 composites per drillhole

For the waste domains (MINDOMS 101, 102 and 103) average composite grades were assigned.

### 11.9.1 Validation of Grade Estimate

Following grade estimation, a statistical and visual assessment of the block model was undertaken to; 1) assess successful application of the estimation passes 2) to ensure that as far as the data allowed, all blocks within mineralisation domains were estimated and 3) the model estimates performed as expected. The model validation methods carried out included:

- On-screen visual assessment of composite and block model grades;
- SWATH plot (model grade profile) analysis and;
- Mean grade check

#### 11.9.1.1 On-Screen Check

An on-screen visual assessment of drill hole, composite and block model grades was carried out. Example cross sections of Fe grades are shown in Figure 11.22 and Figure 11.23. Visually the model was considered to spatially reflect the composite grades.

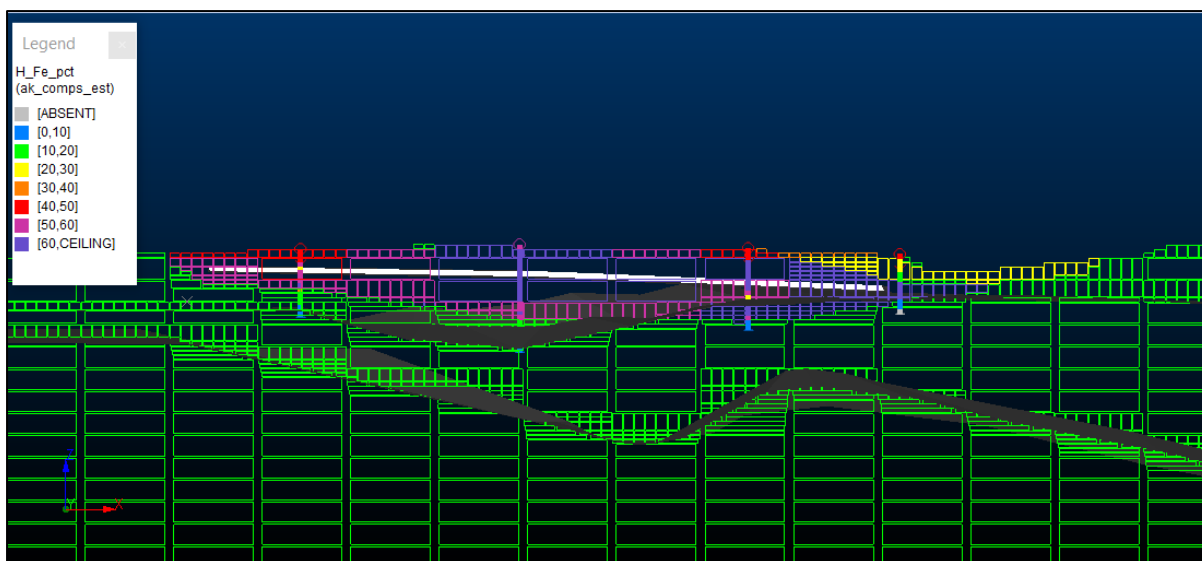


Figure 11.22: Section Showing Model vs Downhole Composite Grades in MINDOM1

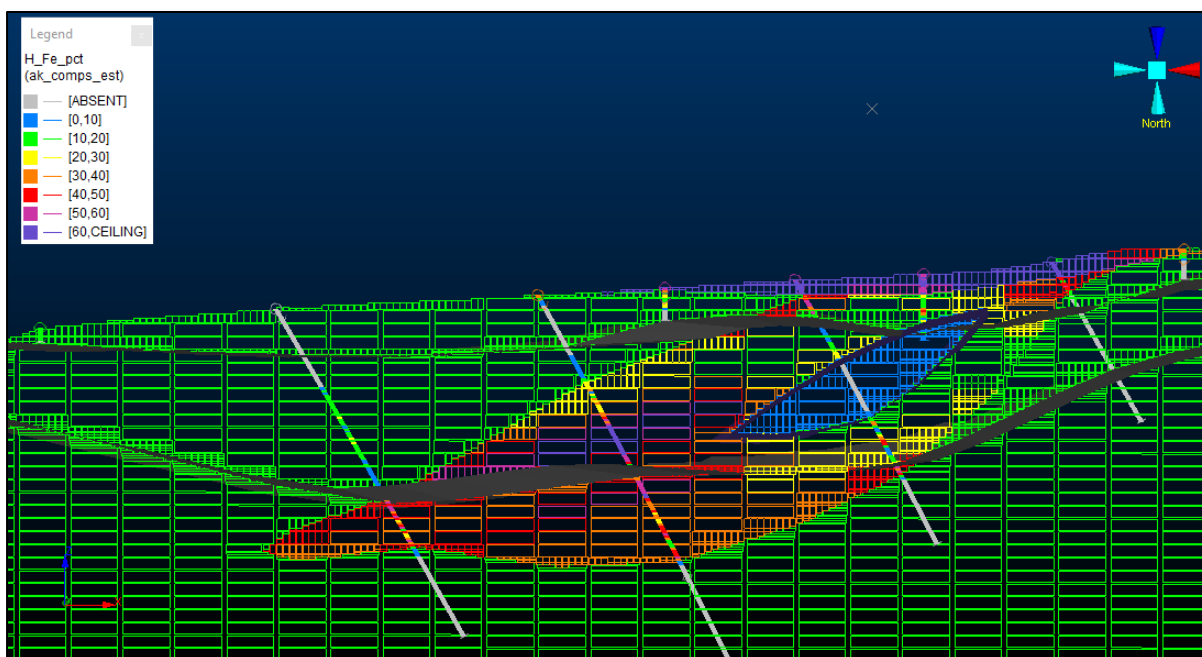


Figure 11.23: Section Showing Model vs Downhole Composite Grades in MINDOM 2 & 3

### 11.9.1.2 SWATH Analysis

Swath plots were generated from the model by averaging composites and blocks along panels. Swath plots were generated for all estimation methods and should exhibit a close relationship to the composite data upon which the estimation is based. An example Swath analysis for Domain 1 of South Zone is shown in Figure 11.24. Overall, the Swath plots illustrated a good correlation between the composites and the block grades.

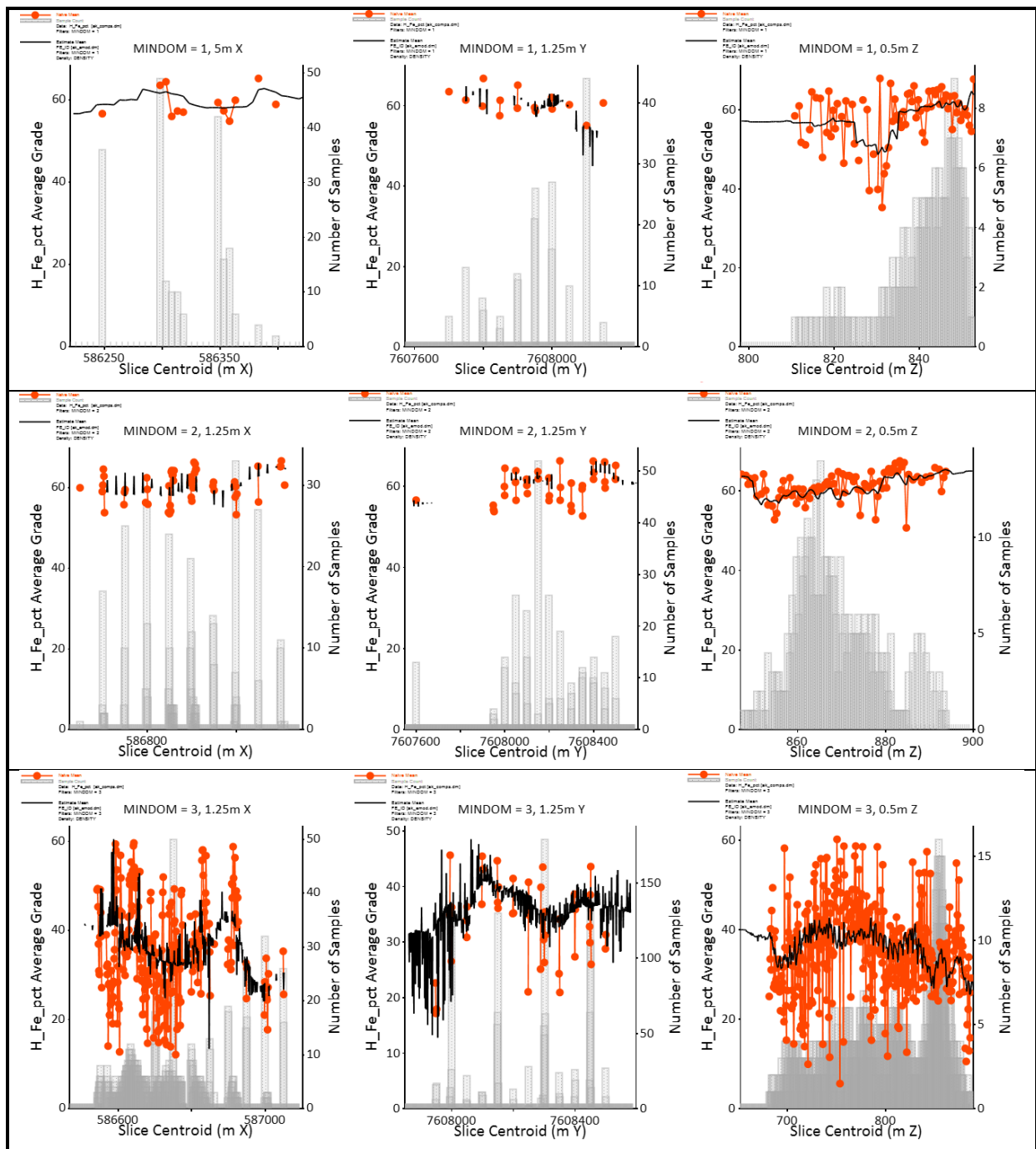


Figure 11.24: Example Swath Plots for MINDOM 1, 2 and 3 (Fe %)

### 11.9.1.3 Mean Grade Check

Statistical analysis of the block model was carried out for comparison against the composited drillhole data. This analysis provides a check on the reproduction of the mean grade of the composite data against the model over the global domain. Typically, the mean grade of the block model should not be significantly greater or less than that of the samples from which it has been derived. The mean block model grade for each MINDOM domain and its corresponding mean composite grades are shown in Table 11.12.

**Table 11.12: Comparison of Average Grades by Estimation Domain**

Variable	MINDOM	Mean Composite Grade	Estimated Block Grade (Tonnage Weighted)
Fe%	1	59.436	59.923
	2	60.685	60.584
	3	35.396	37.760
	4	22.362	22.250
	5	28.275	28.891
	6	37.665	37.483
	7	33.641	33.552
	101	7.580	7.580
	102	30.426	30.426
	103	12.735	12.735
Al <sub>2</sub> O <sub>3</sub> %	1	2.657	2.633
	2	3.549	3.567
	3	3.962	2.899
	4	3.826	3.775
	5	14.951	15.229
	6	10.533	10.697
	7	2.328	2.233
	101	8.387	8.387
	102	4.674	4.674
	103	7.383	7.383
P%	1	0.115	0.111
	2	0.103	0.105
	3	0.168	0.200
	4	0.179	0.185
	5	0.039	0.040
	6	0.062	0.060
	7	0.140	0.144
	101	0.087	0.087
	102	0.099	0.099
	103	0.093	0.093
SiO <sub>2</sub> %	1	7.115	6.904
	2	5.163	5.074
	3	23.137	19.860
	4	33.320	33.219
	5	35.129	34.786
	6	27.584	27.427
	7	15.400	14.302
	101	49.807	49.807
	102	17.231	17.231
	103	40.445	40.445
Mn%	1	0.117	0.115
	2	0.092	0.083
	3	0.120	0.101
	4	0.125	0.128
	5	0.163	0.145
	6	0.173	0.175
	7	0.117	0.116
	101	0.094	0.094
	102	0.203	0.203
	103	0.129	0.129
TiO <sub>2</sub> %	1	0.107	0.109
	2	0.152	0.148
	3	0.163	0.121
	4	0.170	0.167
	5	0.663	0.683
	6	0.469	0.473
	7	0.075	0.069
	101	0.404	0.404
	102	0.183	0.183
	103	0.347	0.347

For personal use only

Where discrepancies between the composite mean grades and block model mean grades were observed, these were checked by WAI and seen to result from the spatial distribution of the data rather than errors in the grade estimation. Overall, WAI considers the composite grades and block model grades to be sufficiently comparable.

#### 11.9.1.4 Validation Summary

Globally no indications of significant over or under estimation are apparent in the model nor were any obvious interpolation issues identified. From the perspective of conformance of the average model grade to the input data, WAI considers the model to be a satisfactory representation of the sample data used and an indication that the grade interpolation has performed as expected.

### 11.10 Mineral Resource Classification

The Bekisopa South deposit is classified in accordance with the Australasian Code for Reporting of Exploration Results, Mineral Resources and Ore Reserves [the JORC Code (2012)].

#### 11.10.1 The JORC Code 2012

The main principles governing the operation and application of the JORC Code (2012) are transparency, materiality and competence.

- Transparency requires that the reader of a Public Report is provided with sufficient information, the presentation of which is clear and unambiguous, to understand the report and is not misled;
- Materiality requires that a Public Report contains all the relevant information which investors and their professional advisers would reasonably require, and reasonably expect to find in the report, for the purpose of making a reasoned and balanced judgement regarding the Exploration Results, Mineral Resources or Ore Reserves being reported; and
- Competence requires that the Public Report be based on work that is the responsibility of suitably qualified and experienced persons who are subject to an enforceable professional code of ethics.

Extracts from the JORC Code (2012) defining the types of mineral resources and reserves are presented below. However, the fundamental consideration to classify a Mineral Resource in accordance with the guidelines of the JORC Code (2012) is that it has a “*reasonable prospect for eventual economic extraction*”.

A ‘Mineral Resource’ is a concentration or occurrence of material of intrinsic economic interest in or on the Earth’s crust, in such form and quantity that there are reasonable prospects for eventual economic extraction. The location, quantity, grade, geological characteristics and continuity of a Mineral Resource are known, estimated or interpreted from specific geological evidence and

knowledge. Mineral Resources are sub-divided, in order of increasing geological confidence, into Inferred, Indicated and Measured categories.

A 'Measured Mineral Resource' is that part of a Mineral Resource for which tonnage, densities, shape, physical characteristics, grade and mineral content can be estimated with a high level of confidence. It is based on detailed and reliable exploration, sampling and testing information gathered through appropriate techniques from locations such as outcrops, trenches, pits, workings and drillholes. The locations are spaced closely enough to confirm geological and/or grade continuity.

An 'Indicated Mineral Resource' is that part of a Mineral Resource for which tonnage, densities, shape, physical characteristics, grade and mineral content can be estimated with a reasonable level of confidence. It is based on exploration, sampling and testing information gathered through appropriate techniques from locations such as outcrops, trenches, pits, workings and drillholes. The locations are too widely or inappropriately spaced to confirm geological and/or grade continuity but are spaced closely enough for continuity to be assumed.

An 'Inferred Mineral Resource' is that part of a Mineral Resource for which tonnage, grade and mineral content can be estimated with a low level of confidence. It is inferred from geological evidence and assumed but not verified geological and/or grade continuity. It is based on information gathered through appropriate techniques from locations such as outcrops, trenches, pits, workings and drillholes which may be limited or of uncertain quality and reliability.

#### **11.10.2 Considerations for Bekisopa South Classification**

The Mineral Resource classification for the Bekisopa South deposit was undertaken by WAI in accordance with the Australasian Code for Reporting of Exploration Results, Mineral Resources and Ore Reserves [JORC Code (2012)]. Mineral Resource classification included a review of the confidence in the drillhole data, the geological interpretation, geological continuity, data density and orientation, spatial grade continuity and overall confidence in the Mineral Resource Estimate. WAI considers that the Bekisopa South deposit has been sufficiently explored to assign Indicated and Inferred mineral resources as defined by the JORC Code (2012).

The key drillhole spacing for the allocation of resources by area can be summarised as follows:

- Measured Mineral Resources – Despite the relatively close spaced drilling in areas of Bekisopa South, WAI believes that an absence of an overall geological and structural model precludes the classification of Measured Mineral Resources.
- Indicated Mineral Resources – Those areas of the DSO zones (MINDOMs 1 and 2) covered by exploration drillholes on a grid of 50m x 50m.
- Inferred Mineral Resources:
  - DSO zones (MINDOMs 1 and 2) - all remaining areas outside of the 50m x 50m spaced grid or where geological complexity is observed.

- Green Steel zone (MINDOM 3) – the moderately weathered and unweathered portions (including areas covered by deeper drillholes at a spacing of 100m x 150m) were classified as Inferred Mineral Resources. The highly weathered portion of the Green Steel zone was excluded due to higher levels of impurities associated with this zone.

An isometric view of the Bekisopa South deposit showing the Mineral Resource classification is shown in Figure 11.25

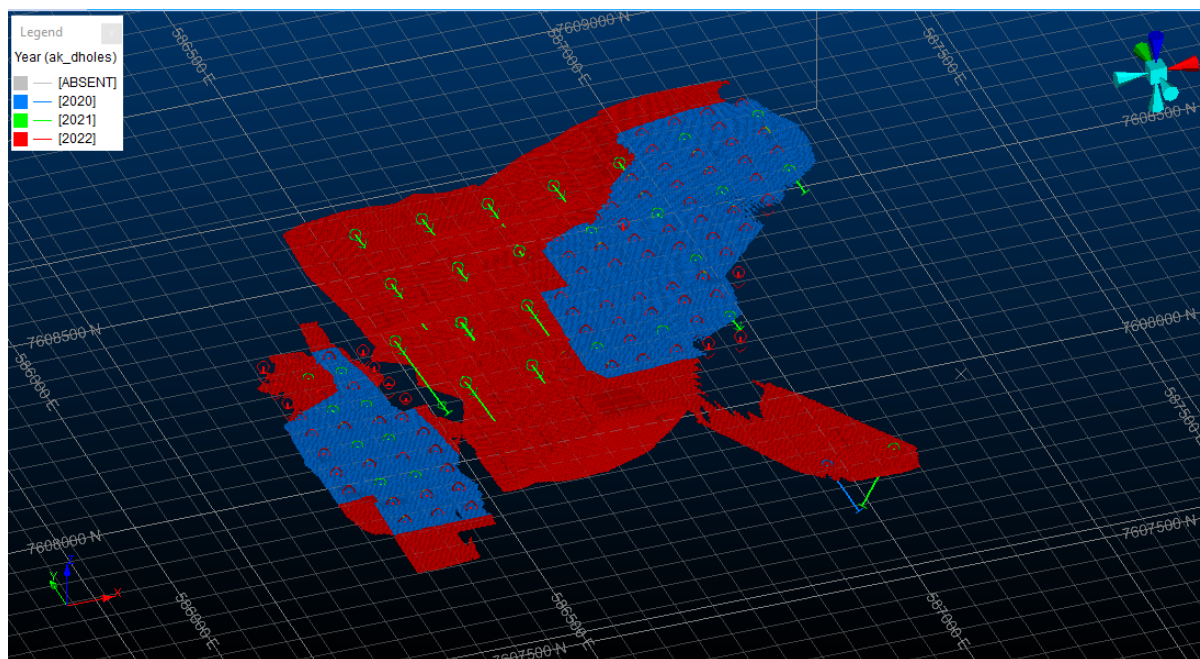


Figure 11.25: Bekisopa South Mineral Resource Classification (Blue – Indicated; Red – Inferred)

### 11.10.3 Expectations of Economic Extraction

For a deposit, or portion of a deposit, to be classified as a Mineral Resource there must be reasonable prospects for eventual economic extraction (the JORC Code [2012]). The model classified as described above was limited by suitable economic and technical parameters (based on the October 2022 Scoping Study). The prospects for eventual economic extraction were tested in the first instance by running an open pit optimisation using the indicative processing costs and long-term product pricing parameters listed in Table 11.13.

Table 11.13: Akora MRE Constraint Optimisation Parameters			
Parameter	Unit	DSO Zones	Green Steel Zone
Mining Cost Ore	US\$/t	2*	3*
Mining Cost Waste	US\$/t	2*	3*
Re-handling Cost	US\$/t	1.00	
Processing cost	US\$/t mined	3*	10*
	US\$/t conc	3*	27*
Transport & Logistics	US\$/t conc	25.00	
G&A	US\$/t ore	0.50	

Royalty Cost	%	4	
Metallurgical Recovery	%	100	54
Concentrate Grade	%Fe	67	67
Discount Rate	%	10	
Overall Pit Slope Angles	°	40	
Mining Recovery	%	0	
Mining Dilution	%	0	
62% Fe Conc Price	US\$/t conc	110*	
65% Fe Conc Price	US\$/t conc	135*	
67% Fe Conc Price	US\$/t conc	150*	

\* Estimated long-term rounded costs and product prices for optimisation purposes

The low grade mineralized zones (MINDOMs 4, 5, 6 and 7) and the highly weathered portion of the Green Steel zone (MINDOM 3) were also included in the optimization process and used the parameters for the Green Steel zone shown in Table 11.4. These zones, however, were excluded from the final Mineral Resource statement as they are not currently considered by Akora as part of the Bekisopa Project due to lower Fe grades or higher levels of impurities.

#### 11.11 Cut-Off Grades for Reporting Resources

No cut-off grades are required for the DSO zones (MINDOMs 1 and 2). A cut-off grade of 36% Fe was applied to the Green Steel zone (MINDOM 3) to provide a head grade of 45% Fe based on the October 2022 Scoping Study. No Mineral Resources are reported for the low-grade zones (MINDOMs 4, 5, 6 and 7) or the highly weathered portion of the Green Steel zone (MINDOM 3) as described in Section 11.10.3.

#### 11.12 Mineral Resource Statement

The Mineral Resource Estimate for the Bekisopa South Iron Project is classified in accordance with the Australasian Code for Reporting of Exploration Results, Mineral Resources and Ore Reserves [JORC Code (2012)].

A summary of the Mineral Resource statement is shown in Table 11.14. The effective date of the Mineral Resource Estimate is 26<sup>th</sup> April, 2023. The stated Mineral Resources are not materially affected by any known environmental, permitting, legal, title, taxation, socio-economic, marketing, political or other relevant issues, to the best knowledge of the author. There are no known mining, metallurgical, infrastructure, or other factors that materially affect this Mineral Resource Estimate, at this time.

**Table 11.14: Mineral Resource Estimate for the Bekisopa South Iron Project (26<sup>th</sup> April, 2023)**

Classification	Tonnes (Mt)	Density (t/m <sup>3</sup> )	Fe (%)	Al <sub>2</sub> O <sub>3</sub> (%)	Mn (%)	P (%)	SiO <sub>2</sub> (%)	TiO <sub>2</sub> (%)
<b>Western DSO Zone</b>								
Indicated	1.63	3.68	60.15	2.65	0.115	0.107	7.01	0.107
Inferred	0.33	3.74	58.83	2.54	0.115	0.131	6.37	0.120
<b>Eastern DSO Zone</b>								
Indicated	2.80	3.21	61.28	3.38	0.088	0.104	4.80	0.143
Inferred	0.79	2.92	58.13	4.23	0.066	0.107	6.04	0.169
<b>Total DSO</b>								
Indicated	4.42	3.37	60.86	3.11	0.098	0.105	5.61	0.129
Inferred	1.12	3.13	58.34	3.73	0.081	0.114	6.14	0.154
<b>Green Steel Zone</b>								
Inferred	34.00	4.02	45.26	2.14	0.090	0.237	13.82	0.083

**Notes:**

1. Mineral Resources for the DSO zones are not reported using a cut-off grade as no cut-off grade is required for these zones. Mineral Resources for the Green Steel zone are reported using a cut-off grade of 36% Fe.
2. Mineral resources are limited to an optimised open pit shell based on appropriate economic and mining parameters.
3. Mineral Resources are not Ore Reserves until they have demonstrated economic viability based on a Pre-Feasibility Study or Feasibility Study.
4. Mineral Resources are reported inclusive of any Ore Reserves.
5. Mineral Resources for the Bekisopa South Iron Project have been classified in accordance with the guidelines of the JORC Code (2012) by Richard Ellis, an independent Competent Person as defined by JORC.
6. The Mineral Resource estimate has not been affected by any known environmental, permitting, legal, title, taxation, socio-political, marketing or any other relevant issues.
7. Contained metal refers to estimated contained metal in the ground not adjusted for metallurgical recovery.
8. All figures are rounded to reflect the relative accuracy of the estimate, and apparent errors may occur due to rounding.

## 12 CONCLUSIONS AND RECOMMENDATIONS

Wardell Armstrong International was commissioned by Akora to produce an updated Mineral Resource Estimate for the Bekisopa South Iron Project in south central Madagascar. The project is a greenfield and Akora is intending to develop it as an open pit operation with a focus on rapidly bringing into production near-surface, high-grade oxidised material as DSO which is found in two zones (Eastern and Western zones). Underlying the DSO is a larger, deeper zone of transitional and sulphide mineralisation termed the “Green Steel” zone which is considered amenable for use in the production of green steel.

Mineral Resource Estimation was undertaken by WAI using drillhole information from the 2020, 2021 and 2022 drilling programmes completed by Akora. A 3D block modelling approach using Datamine Studio RM and Snowden Supervisor software was used. Exploration data were imported and verified before appropriate mineralisation and weathering envelopes were defined by 3D wireframes, based on the current understanding of the deposit. Mineralisation domains were based on nominal cut-off grades of 58% Fe for the DSO and 25% Fe for the Green Steel zone. Weathering surfaces were constructed for the base of complete weathering and base of moderate weathering using geological logging data. The wireframe envelopes were used as the basis for a volumetric block model based on a parent cell size of 20m x 20m x 5m, but with sub-celling allowed to 2.5m x 2.5m x 1m to give a best fit against wireframe boundaries and limits. The block model was coded with appropriate keyfields for mineralised domain and weathering horizons.

Grades for Fe, SiO<sub>2</sub>, Al<sub>2</sub>O<sub>3</sub>, Mn, P, and TiO<sub>2</sub> were estimated into the block model representing each mineralised domain. Grade estimation was carried out using inverse distance weighting estimation. Estimated grades were validated globally, locally, and visually. Density was estimated into the block model from drillhole data using regressed density values from Fe grades.

The MRE for the Bekisopa South deposit is classified in accordance with the JORC Code (2012). Indicated Mineral Resources were assigned to areas of the DSO zones covered by exploration drillholes on a grid of 50m x 50m. Inferred Mineral Resources were classified for all remaining areas outside of the 50m x 50m spaced grid or where geological complexity is observed. For the Green Steel zone, the moderately weathered and unweathered portions (including areas covered by deeper drillholes at a spacing of 100m x 150m) were classified as Inferred Mineral Resources. The highly weathered portion of the Green Steel zone was not classified as a Mineral Resource due to higher levels of impurities associated with this zone.

The MRE was limited by an open pit optimisation using technical and economic parameters.

As of the 26<sup>th</sup> April, 2023, with no cut-off grade applied (not required), the total Indicated Mineral Resources for the DSO zones (Western and Eastern) is 4.42Mt at an average grade of 60.86% Fe, and the total Inferred Mineral Resources for these zones is 1.12Mt at an average grade of 58.34% Fe. At a cut-off grade of 36% Fe, the total Mineral Resources (wholly Inferred) for the Green Steel zone are 34.00Mt at an average grade of 45.26% Fe.

In WAI's opinion, given the availability of DSO material, and supplemented by large tonnages of transitional and primary mineralisation directly underneath, that is amenable for use in the production of "green steel", the Bekisopa South deposit warrants further exploration and WAI makes the following recommendations:

#### **12.1.1 Exploration Procedures**

WAI makes the following recommendations regarding density and DTT testwork:

- Validate density measurements with laboratory testwork to confirm accuracy of field measurements. Additional density testwork should be undertaken to further confirm the densities for DSO zones;
- A geological and structural model for the deposit should be developed to increase the understanding of areas of the distribution of DTT recoveries within the deposit;
- WAI recommends that DTT testwork is tailored to specific mineralisation/geological domains. This will allow better understanding of the relationship between magnetic susceptibility and DTT recoveries, and any relationship between DTT and mineralogy/lithology.

#### **12.1.2 QA/QC Procedures and Sample Analysis**

WAI makes the following recommendations with regards to the QA/QC procedures:

- Field duplicates should be incorporated to track the precision of sampling throughout the entire drilling process;
- Samples with Sulphur values above the maximum reporting limit (~5%) should be re-assayed by the laboratory, typically using a different method with greater reporting limits; this would allow for estimation of Sulphur in the block model;
- Use of an umpire lab to improve confidence in assay results (for example, some ALS internal standards reported anomalous values and should be further investigated); and
- Additional twinning of drillholes should be undertaken to further assess the short-range grade variability through the deposit.

#### **12.1.3 Exploration Database Management**

WAI makes the following recommendations with regards to the Akora exploration database:

- A specialist exploration database package such as Fusion may be beneficial in organising exploration data in a more robust manner. This type of software generally has in-built data validation tools, authorisation protocol and provision made for the inclusion of QA/QC samples. As the project database expands, this will become increasingly important.

#### **12.1.4 Exploration Programme**

WAI believes that the work completed by Akora thus far has been in line with industry standards and makes the following recommendations (where applicable):

- Consider alternative percussion drilling methods to lower drilling costs, particularly for the near-surface DSO material (WAI understands that alternative drilling contractors are difficult to find in Madagascar);
- Orientated drill core should be incorporated into the next phase of deeper drilling at Bekisopa to gain better understanding of the deposit geology and structure. Attempting orientated core on shallow, regolith material is unlikely to provide useful information;
- Re-logging of core to enhance understanding and classification of lithologies. For example, some core may have been incorrectly logged as gneiss yet shows characteristics of amphibolite (i.e. no strong foliation/gneissose banding);
- Cleaning and re-sampling of existing UNDP and BRGM trenches. These offer an excellent source of information at a much lower cost than drilling, and could potentially be incorporated into an MRE if sampling is performed to a high standard with QA/QC implemented. The near-surface DSO is the main focus and therefore trenching will enhance the confidence in the early stages of the mine plan;
- Additional short, vertical drillholes have already been planned for 2023 to further test the DSO potential of Bekisopa North and Central. WAI would recommend including deeper holes within this programme to continue to test the depth potential of the deposit. WAI understands that some additional short drillholes will also be completed at the DSO zones at Bekisopa South in 2023 as part of this programme; and
- WAI recommends that additional drilling should be completed at Bekisopa South, specifically:
  - Along the north and south strike extents of both the Western and Eastern DSO zones;
  - To the west of the Western zone to test high grade DSO intersected in the drillholes from BEKD146 through to BEKD134 further north;
  - To the east of the Eastern Zone to test high grade DSO intersected in BEKD081 & BEKD091; and
  - Infill drilling at depth to:
    - Define the Green Steel resource potential;
    - Improve understanding of the geology and structure of the orebody and distribution of mineralisation types (massive, coarse disseminated and fine disseminated);
    - Better determine the relationship between oxidation and grade; and
    - Upgrade Inferred Mineral Resources.

In WAI's opinion, as demonstrated above, the DSO potential has not been fully defined, and therefore subject to positive results, additional DSO and Green Steel tonnes could be added to the Mineral Resource Estimate above.

The Bekisopa Project benefits from high grade DSO material, close to surface, with low impurities, additional scope for increased tonnes, in a location with a low population, with strong local and governmental support, in WAI's opinion, Akora should advance the project.

## 13 REFERENCES

Besairie, H. 1971. Carte Geologique. Feuille 1. Diego-Suarez. 1:500,000. Service Geologique de Madagasikara, Tananarive.

Braga, F.C.S, Rosière, C.A., Santos, J.O.S., Hagemann, S.G., Danyushevsky, L., and Salles, P.V. 2021. Geochemical and tectonic constraints on the genesis of iron formation-hosted magnetite-hematite deposits at the Guanhões Block (Brazil) by contact metasomatism with pegmatite intrusions. *Ore Geology Reviews*, Volume 129, 103931.

Collins, AS., Kinny, PD., and Razakamanana, T., 2012. Depositional age, provenance and metamorphic age of metasedimentary rocks from southern Madagascar. *Gondwana Research*. Volume 21, Issues 2–3, 353-361pp.

Emerick, C.M. and Duncan, R.A. 1982. Age progressive volcanism in the Comores Archipelago, western Indian Ocean and implications for Somali Plate Tectonics. *Earth and Planetary Science Letters*, 60, 415-28pp.

GAF-BGR, 2008. Final Report: Explanatory notes for the Anosyen Domain, southeast Madagascar. Réalisation des travaux de cartographie géologique de Madagascar, révision approfondie de la cartographie géologique et minière aux échelles 1/100 000 et 1/500 000 zone Sud. République de Madagascar, Ministère de L'énergie et des Mines (MEM/SG/DG/UCP/PGRM), 93pp.

GAF-BGR, 2009. Final Report: Explanatory notes for the Itremo-Ikalamavony Domain, central and western Madagascar. Réalisation des travaux de cartographie géologique de Madagascar, révision approfondie de la cartographie géologique et minière aux échelles 1/100 000 et 1/500 000 zone Sud. Contrat République de Madagascar, Ministère de L'énergie et des Mines (MEM/SG/DG/UCP/PGRM), 89pp.

Hammarstrom, J.M., Theodore, TG., Kotlyar, BB., Doebrich, JA., Elliott, JE., Nash, JT., John, DA., and Livo, KE. 1986. FE SKARN DEPOSITS. MODEL 18d.

Tucker, R.D., Roig, J.Y, Macey, P.H., Delor, C., Amelin, Y., Armstrong, R.A, Rabarimanana, M.H., Ralison, A.V., 2011. A new geological framework for south-central Madagascar, and its relevance to the "out-of-Africa" hypothesis. *Precambrian Research* 185, 109-130pp.

Westhues, A., Hanchar, J.M., Whitehouse, M.J., and Fisher, C.M. 2012. Did the Kiruna iron ores form as a result of a metasomatic or igneous process? New U-Pb and Nd data for the iron oxide apatite ores and their host rocks in the Norrbotten region of northern Sweden. AGU Fall Meeting Abstract.

For personal use only

**APPENDIX 1: JORC Table 1**

**Section 1 Sampling Techniques and Data**

Criteria	JORC Code explanation	Commentary
<i>Sampling techniques</i>	<ul style="list-style-type: none"> <li>• <i>Nature and quality of sampling (eg cut channels, random chips, or specific specialised industry standard measurement tools appropriate to the minerals under investigation, such as down hole gamma sondes, or handheld XRF instruments, etc). These examples should not be taken as limiting the broad meaning of sampling.</i></li> <li>• <i>Include reference to measures taken to ensure sample representivity and the appropriate calibration of any measurement tools or systems used.</i></li> <li>• <i>Aspects of the determination of mineralisation that are Material to the Public Report.</i></li> <li>• <i>In cases where ‘industry standard’ work has been done this would be relatively simple (eg ‘reverse circulation drilling was used to obtain 1 m samples from which 3 kg was pulverised to produce a 30 g charge for fire assay’). In other cases more explanation may be required, such as where there is coarse gold that has inherent sampling problems. Unusual commodities or mineralisation types (eg submarine nodules) may warrant disclosure of detailed information.</i></li> </ul>	<ul style="list-style-type: none"> <li>• Samples consisted of diamond drill core.</li> <li>• Diamond core (HQ or NTW) is split in half using a core saw or splitter (if clayey or rubbly). A consistent half of the core is broken with a hammer and bagged prior to dispatch prior to the preparation laboratory in Antananarivo. Sample intervals are nominally 1m down hole however samples would terminate at lithological and mineralisation boundaries. Average drill core sample length is 0.87m.</li> <li>• Samples generally weighed 3-5kg and were dried, crushed and pulverised to 85% passing 75 microns at a commercial laboratory.</li> <li>• Handheld pXRF (Bruker Titan S1) was used on site prior to being sent to the preparation lab. XRF was used on entire drill lengths from drillholes BEKD001 to BEKD024, after which XRF measurements were conducted on visually identified mineralisation. The handheld XRF was calibrated upon issue.</li> <li>• Head and concentrate assay analysis was completed by conventional XRF (ME-XRF21u) with recovered magnetic fraction completed using a Davis Tube.</li> </ul>
<i>Drilling techniques</i>	<ul style="list-style-type: none"> <li>• <i>Drill type (eg core, reverse circulation, open-hole hammer, rotary air blast, auger, Bangka, sonic, etc) and details</i></li> </ul>	<ul style="list-style-type: none"> <li>• All drilling is diamond core. Drilling contractor Croft Drilling Services (CDS) completed the diamond drilling programmes in 2020-2022 with a man portable EP200 drilling rig for drill holes less than 100m in length, and a MP500 drilling rig for drill holes greater than 100m in length, using either NTW (56.1mm inner diameter)</li> </ul>

For personal use only

For personal use only

Criteria	JORC Code explanation	Commentary
	<i>(eg core diameter, triple or standard tube, depth of diamond tails, face-sampling bit or other type, whether core is oriented and if so, by what method, etc).</i>	<p>or HQ (63.5mm inner diameter) coring equipment. The holes are generally collared using HQ and changed to NTW between 3m and 27m downhole.</p> <ul style="list-style-type: none"> <li>For diamond drill holes in the Southern Zone, minimum length is 4.69m, maximum length is 260.72m, with an average length of 39.16m across all drill campaigns.</li> <li>The drill core is not orientated.</li> <li>All but three drill holes (BEKD001-BEKD003) from 2020-2021 drill campaigns have been surveyed using a Reflex EZ-Gyro gyroscopic multishot camera at intervals of 10m. All drill holes from this period are within 5° of their planned inclination and within 10° of the planned azimuth, except for BEKD061 which was within 15° of the planned azimuth.</li> <li>No downhole surveys were conducted for 2022 drilling as all holes were vertical and &lt;30m in length.</li> </ul>
<i>Drill sample recovery</i>	<ul style="list-style-type: none"> <li><i>Method of recording and assessing core and chip sample recoveries and results assessed.</i></li> <li><i>Measures taken to maximise sample recovery and ensure representative nature of the samples.</i></li> <li><i>Whether a relationship exists between sample recovery and grade and whether sample bias may have occurred due to preferential loss/gain of fine/coarse material.</i></li> </ul>	<ul style="list-style-type: none"> <li>Total Core Recovery (TCR) was measured on site at the drill rig by the supervising geologist.</li> <li>Drillholes with consistently low recovery (&lt;85%) were re-drilled.</li> <li>Average sample recovery is 94% (any samples recorded as having a TCR&gt;100% were excluded from the statistics).</li> <li>Core recovery is higher in fresh rock (average TCR of 97%) than in weathered rock (average value of 90%).</li> <li>A small number of high-grade samples with low recovery are present in near surface weathered zones however, there is no observed relationship between Fe grade and sample recovery.</li> </ul>
<i>Logging</i>	<ul style="list-style-type: none"> <li><i>Whether core and chip samples have been geologically and geotechnically logged to a level of detail to support appropriate Mineral Resource estimation, mining studies and metallurgical studies.</i></li> <li><i>Whether logging is qualitative or quantitative in nature. Core (or costean, channel, etc) photography.</i></li> <li><i>The total length and percentage of the relevant intersections logged.</i></li> </ul>	<ul style="list-style-type: none"> <li>A set of standard operating procedures for drilling and sampling were prepared by AKORA and Vato Consulting, who supervised the program, and these were always adhered to.</li> <li>Checks and verifications of the accurate measurement of penetration depth were made during drilling and observations and recording of the colour of the water/mud rising from the drill hole were made.</li> <li>The entire length of drill core was logged. Pre-defined codes were used to create consistency in qualitative logging.</li> <li>Logging included: Total Core Recovery (TCR) and Rock Quality Designation (RQD), primary and secondary lithology, weathering, colour (supported by Munsell chart), grain size, mineralisation type (magnetite or hematite), mineralisation style and percentage, structure, magnetic susceptibility, pXRF readings, in addition to general descriptions.</li> <li>All drill holes were logged using a magnetic susceptibility meter to enable accurate distinction between magnetite and hematite rich mineralisation.</li> </ul>

For personal use only

Criteria	JORC Code explanation	Commentary
		<ul style="list-style-type: none"> <li>The entire length of drill core was geotechnically logged for TCR and RQD.</li> <li>All core was photographed both as whole core and half core (after cutting and sampling), in addition to both wet and dry states.</li> <li>Density measurements were made using both the Archimedes method (on competent core) and the Caliper Vernier method (on weathered/incompetent core).</li> </ul>
<p><i>Sub-sampling techniques and sample preparation</i></p>	<ul style="list-style-type: none"> <li><i>If core, whether cut or sawn and whether quarter, half or all core taken.</i></li> <li><i>If non-core, whether riffled, tube sampled, rotary split, etc and whether sampled wet or dry.</i></li> <li><i>For all sample types, the nature, quality and appropriateness of the sample preparation technique.</i></li> <li><i>Quality control procedures adopted for all sub-sampling stages to maximise representivity of samples.</i></li> <li><i>Measures taken to ensure that the sampling is representative of the in situ material collected, including for instance results for field duplicate/second-half sampling.</i></li> <li><i>Whether sample sizes are appropriate to the grain size of the material being sampled.</i></li> </ul>	<ul style="list-style-type: none"> <li>A set of standard operating procedures for drilling and sampling were prepared by AKORA and Vato Consulting, who supervised the drilling programme.</li> <li>All core was fitted together so that a consistent half core could be collected, marked up with a consistent “top” line (line perpendicular to dip and strike, or main foliation) to minimise any bias in the samples. Sample intervals were nominally 1m lengths but truncated by lithological, mineralisation, or structural boundaries.</li> <li>Competent core was split using a core saw whereas incompetent/weathered core was split using hammer and chisel. Sampling equipment was cleaned between samples to minimise the risk of cross contamination.</li> <li>Half core samples were collected into polythene bags along with a paper sample tag. This was then sealed using a cable tie and placed into a second polythene bag with a second paper sample tag and sealed using staples. The remaining half core was kept as a reference sample.</li> <li>The samples were subsequently transferred at regular intervals to the sample preparation facility in Antananarivo (OMNIS) where the following procedures took place: <ul style="list-style-type: none"> <li>Sorting and weighing of samples.</li> <li>Dried at 110°C-120°C until totally dry.</li> <li>Weighing after drying.</li> <li>Jaw crushing to 2mm.</li> <li>Samples are passed through a riffle splitter twice (1:1) to produce a ¼ sample.</li> <li>For selected samples, 100g sub-sample was collected for Davis Tube Recovery.</li> <li>Sub-samples are riffle split to collect 100g with 80% passing 2mm and pulverized to 85% passing 75 microns.</li> <li>The ring mill is cleaned using air and silica chips between samples.</li> <li>Reject pulp samples are stored or used as duplicate samples.</li> <li>A measurement of pXRF is taken on selected pulp samples.</li> </ul> </li> <li>Weight of each sub-sample (-2mm and 2 x -75 microns) are recorded and stored in separate boxes for recovery.</li> <li>All sampling methods and sample sizes are deemed appropriate.</li> </ul>

For personal use only

Criteria	JORC Code explanation	Commentary
<p><i>Quality of assay data and laboratory tests</i></p>	<ul style="list-style-type: none"> <li><i>The nature, quality and appropriateness of the assaying and laboratory procedures used and whether the technique is considered partial or total.</i></li> <li><i>For geophysical tools, spectrometers, handheld XRF instruments, etc, the parameters used in determining the analysis including instrument make and model, reading times, calibrations factors applied and their derivation, etc.</i></li> <li><i>Nature of quality control procedures adopted (eg standards, blanks, duplicates, external laboratory checks) and whether acceptable levels of accuracy (ie lack of bias) and precision have been established.</i></li> </ul>	<ul style="list-style-type: none"> <li>Samples from the 2020 drilling campaign were either sent to ALS Iron Ore Technical Centre in Perth, or ALS geochemistry laboratory in Galway Ireland. All samples from 2021 and 2022 were sent to ALS in Perth. Both laboratories are accredited ISO/IEC 17025:2017.</li> <li>Handheld XRF used by AKORA is the Bruker Titan S1 handheld pXRF. The machine was calibrated by the GeoExploration in January 2021 and included QA/QC samples of blanks and two standards.</li> <li>Analysis at ALS was completed on 100g of pulverised sample with 85% passing 75 microns by ME-XRF21u (un-normalised) for total Fe% and multi element analysis including Al<sub>2</sub>O<sub>3</sub>, SiO<sub>2</sub>, P, S, K<sub>2</sub>O, MgO, Mn, Ni, Pb, Sn, Sr, TiO<sub>2</sub>, V, Zn and Zr.</li> <li>Loss on Ignition (OA-GRA05x) was included at 371°C, 650°C, and 1000°C.</li> <li>Selected mineralised samples were subjected to Davis Tube Recovery (DTT). This included a total of 2,178 samples at Bekisopa South. The DTT concentrate was used to determine concentrate grades of relevant elements including Fe, SiO<sub>2</sub>, P, S, Al<sub>2</sub>O<sub>3</sub>, TiO<sub>2</sub>, and LOI. DTT mass Recovery was also reported as a percentage of the measured feed.</li> <li>QC samples consisted of blank samples, pulp duplicates and certified reference materials (CRM) submitted both by AKORA and internally by ALS. CRM and blank samples were included every 40<sup>th</sup> sample with two to four pulp duplicates included every 100 samples.</li> <li>Blank samples submitted by AKORA included silica chips manufactured by African Mineral Standards (AMIS0052, AMIS0439, AMIS0681, and AMIS0793) which have trace amounts of Fe, all below 1%. All blank samples, including the ALS internal blanks, performed well with all samples returning &lt;1% Fe showing no signs of significant contamination between samples.</li> <li>A total of 5 CRMs were submitted by AKORA across the various drilling campaigns. The accuracy of analysis was measured against ±2 and ±3 standard deviations. Any samples reporting assays outside ±3 standard deviations were re-sampled, including 5 samples either side in the batch, and the subsequent results were updated in the assay database. AKORA’s CRM performance is within acceptable levels and therefore accuracy of assays is within acceptable limits and no major bias is observed.</li> <li>A total of 5 CRMs were submitted by ALS as part of their internal QA/QC procedures during the 2022 drilling programme. The results were reviewed by WAI and most CRM values reported assays within acceptable limits. Two CRMs reported several failures, and this is currently being investigated by AKORA.</li> <li>Pulp duplicate samples were assessed based on Half Absolute Relative Difference (HARD) acceptance criteria which includes 90% of the sample population being less than 10% HARD value. A total of 100% of pulp duplicate samples were within the acceptable criteria and therefore the assaying is considered to have a high level of precision.</li> </ul>

For personal use only

Criteria	JORC Code explanation	Commentary
<i>Verification of sampling and assaying</i>	<ul style="list-style-type: none"> <li><i>The verification of significant intersections by either independent or alternative company personnel.</i></li> <li><i>The use of twinned holes.</i></li> <li><i>Documentation of primary data, data entry procedures, data verification, data storage (physical and electronic) protocols.</i></li> <li><i>Discuss any adjustment to assay data.</i></li> </ul>	<ul style="list-style-type: none"> <li>Significant intersections have not been independently verified.</li> <li>Twinned holes were not deliberately drilled however closely spaced re-drilled holes were analysed and showed that downhole grades generally correlated downhole.</li> <li>Primary logging data is collected on hard copy logging sheets which are checked by consultants Vato Consulting and transferred to a Microsoft Excel database. Assay data, including QA/QC, received from the laboratory is also checked on site before being entered into a Microsoft Excel database.</li> <li>No adjustments were made to the assay data.</li> </ul>
<i>Location of data points</i>	<ul style="list-style-type: none"> <li><i>Accuracy and quality of surveys used to locate drill holes (collar and down-hole surveys), trenches, mine workings and other locations used in Mineral Resource estimation.</i></li> <li><i>Specification of the grid system used.</i></li> <li><i>Quality and adequacy of topographic control.</i></li> </ul>	<ul style="list-style-type: none"> <li>All drill hole collars have been provisionally located using a hand-held GPS (+/- 5m accuracy) and then subsequently surveyed by DGPS.</li> <li>WAI were able to verify the position of 18 drill collars at Bekisopa South during a site visit in 2023 with a hand-held GPS.</li> <li>The grid system used is UTM, WGS84, Zone 38 Southern Hemisphere.</li> <li>An accurate topographic survey was completed by FuturMap, a local surveying consultant. The survey was conducted using a PHANTOM 4 Pro type drone, and a pair of Leica System 1200 dual frequency GPS. An accuracy of 10mm horizontal and 20mm vertical is quoted.</li> </ul>
<i>Data spacing and distribution</i>	<ul style="list-style-type: none"> <li><i>Data spacing for reporting of Exploration Results.</i></li> <li><i>Whether the data spacing and distribution is sufficient to establish the degree of geological and grade continuity appropriate for the Mineral Resource and Ore Reserve estimation procedure(s) and classifications applied.</i></li> <li><i>Whether sample compositing has been applied.</i></li> </ul>	<ul style="list-style-type: none"> <li>Data spacing at Bekisopa South is nominally 100m x 150m in areas of deeper drillholes while shallow DSO zones have been drilled at a spacing of 50m x 50m.</li> <li>The data spacing and distribution is considered appropriate to establish geological and grade continuity for the style of mineralisation, particularly within DSO mineralisation and the classification of Mineral Resources.</li> <li>Downhole surveys were conducted every 10m downhole in 2020-2021 drilling at Bekisopa South. All drill holes are within 5° of their planned inclination and within 10° of the planned azimuths, except for BEKD061 which was within 15° of the planned azimuth.</li> <li>No down hole surveys were conducted for 2022 drilling as drillholes were shallow (&lt;30m) and vertical.</li> <li>No sample compositing was applied.</li> </ul>
<i>Orientation of data in relation to</i>	<ul style="list-style-type: none"> <li><i>Whether the orientation of sampling achieves unbiased sampling of possible structures and the extent to which this is known, considering the deposit type.</i></li> <li><i>If the relationship between the drilling</i></li> </ul>	<ul style="list-style-type: none"> <li>The ironstone unit has a strong north-south trend with outcrops, trenches, and magnetics showing a steep to shallow westerly dip. Drilling in 2020 and 2021 is dominantly orientated east, perpendicular to interpreted mineralisation and considered to be optimal.</li> <li>Drilling in 2022 is vertical which targets tabular sub-horizontal DSO mineralisation and considered optimal for this style of mineralisation.</li> </ul>

For personal use only

Criteria	JORC Code explanation	Commentary
<i>geological structure</i>	<i>orientation and the orientation of key mineralised structures is considered to have introduced a sampling bias, this should be assessed and reported if material.</i>	<ul style="list-style-type: none"> <li>The current structural interpretation is an orocline controlling sheet-like mineralisation. A single hole orientated to the west in the far south of the tenement suggests the sequence is dipping east here, suggesting an anticlinal structure in this area.</li> <li>No sample bias is evident.</li> </ul>
<i>Sample security</i>	<ul style="list-style-type: none"> <li><i>The measures taken to ensure sample security.</i></li> </ul>	<ul style="list-style-type: none"> <li>Chain of Custody procedures are implemented to document the possession of the samples from collection to storage, customs, export, analysis, and reporting of results. The Chain of Custody forms are permanent records of sample handling and off-site dispatch.</li> <li>The on-site Geologist is responsible for the care and security of the samples from the sample collection to the export stages. Samples prepared are stored in the preparation facility in labelled sealed plastic bags.</li> <li>The Chain of Custody form contains the following the information: <ul style="list-style-type: none"> <li>Sample identification numbers;</li> <li>Type of sample;</li> <li>Date of sampling;</li> <li>List of analyses required;</li> <li>Customs approval;</li> <li>Waybill number;</li> <li>Name and signature of sampling personnel;</li> <li>Transfer of custody acknowledgement.</li> </ul> </li> <li>Samples are delivered to the analytical laboratory by courier. A copy of the Chain of Custody form is signed, dated, and placed in a sealable plastic bag taped on top of the lid of the sample box. Each sample batch is accompanied by a Chain of Custody form.</li> <li>One box of samples was incorrectly sent to ALS Ireland, and one sent to Perth. The laboratory in Ireland subsequently sent the sample box to Perth where both boxes of samples were analysed. No tampering of either box was reported to have been observed.</li> </ul>
<i>Audits or reviews</i>	<ul style="list-style-type: none"> <li><i>The results of any audits or reviews of sampling techniques and data.</i></li> </ul>	<ul style="list-style-type: none"> <li>No external audits of the sampling and assaying techniques have been carried out.</li> <li>As part of this MRE, WAI has reviewed the documented practices employed by AKORA and their consultant Vato Consulting with respect to diamond drilling, sampling, QA/QC, and assaying, and believe that the processes are appropriate, and that the data is of reasonable quality and suitable for use in Mineral Resource estimation.</li> </ul>

## Section 2 Reporting of Exploration Results

Criteria	JORC Code explanation	Commentary
<i>Mineral tenement and land tenure status</i>	<ul style="list-style-type: none"> <li>Type, reference name/number, location and ownership including agreements or material issues with third parties such as joint ventures, partnerships, overriding royalties, native title interests, historical sites, wilderness or national park and environmental settings.</li> <li>The security of the tenure held at the time of reporting along with any known impediments to obtaining a licence to operate in the area.</li> </ul>	<ul style="list-style-type: none"> <li>The Company completed the acquisition of the minority interest in Iron Ore Corporation of Madagascar sarl held by Cline Mining Corporation on 5 August 2020.</li> <li>The licenses that comprise the overall Bekisopa Project (inclusive of Northern, Central and Southern areas) consist of one granted research permit (PR 10430) and one granted small scale mining permit (PRE 3757). Of these, Bekisopa South falls within the PR 10430 licence.</li> <li>Applications to renew the licenses were made by Akora in May 2022 in a timely manner, however, feedback from the authorities is still awaited. It not uncommon in these instances, for renewal applications (even when made timeously and in accordance with the prevailing mining law) to extend beyond anticipated timeframes. The requisite environmental commitment plan for exploration was submitted by Akora to the Direction Générale des Mines on 30<sup>th</sup>March, 2021.</li> </ul>
<i>Exploration done by other parties</i>	<ul style="list-style-type: none"> <li>Acknowledgment and appraisal of exploration by other parties.</li> </ul>	<ul style="list-style-type: none"> <li>Exploration has been conducted by UNDP (1976 - 78) and BRGM (1958 - 62). Final reports on both episodes of work are available and have been utilised in the recent IGR included in the AKORA prospectus. Airborne magnetics was flown for the government by Fugro and has since been obtained, modelled, and interpreted by Cline Mining and AKORA.</li> </ul>
<i>Geology</i>	<ul style="list-style-type: none"> <li>Deposit type, geological setting and style of mineralisation.</li> </ul>	<ul style="list-style-type: none"> <li>The tenure was acquired by AKORA during 2014 and work since then has consisted of: <ul style="list-style-type: none"> <li>Data compilation and interpretation;</li> <li>Confirmatory rock chip sampling (118 samples) and mapping;</li> <li>Re-interpretation of airborne geophysical data;</li> <li>Ground magnetic surveying (305 line kilometres);</li> <li>The 2020 – 2022 drilling programme of 7,378m diamond core drilling from 150 drillholes, with 4,816m diamond core drilling in 123 holes at Bekisopa South.</li> </ul> </li> <li>The mineralisation occurs as a series of magnetite bearing gneisses and calc-silicates that occur as zones between 50m and 150m combined true width.</li> <li>The mineralisation occurs as layers of massive magnetite (sometimes altered to hematite) between 1m and 7m true widths plus a lower grade zone that consists of lenses, stringers, boudins and blebs of magnetite aggregates that vary from 1cm to 10's of cm wide within a calc-silicate/gneiss unit (informally termed "coarse disseminated" here). These units sometimes have an outer halo of finer disseminated magnetite (informally termed "disseminated" here).</li> <li>Infill drilling at Bekisopa South has confirmed DSO mineralisation, which is interpreted as eastern and western zones, coupled with the 6km-7km strike of mapped mineralisation and magnetic anomaly within</li> </ul>

For personal use only

Criteria	JORC Code explanation	Commentary
		<p>the AKORA tenement suggests a large potential tonnage. The recent drilling has shown that the surface mineralisation continues at depth.</p> <ul style="list-style-type: none"> <li>The bands and blebs of massive magnetite aggregates along with preliminary LIMS testwork suggest that a good iron product may be obtained using a simple crush to -2mm followed by magnetic separation.</li> </ul>
<i>Drill hole Information</i>	<ul style="list-style-type: none"> <li><i>A summary of all information material to the understanding of the exploration results including a tabulation of the following information for all Material drill holes:</i> <ul style="list-style-type: none"> <li><i>easting and northing of the drill hole collar</i></li> <li><i>elevation or RL (Reduced Level – elevation above sea level in metres) of the drill hole collar</i></li> <li><i>dip and azimuth of the hole</i></li> <li><i>down hole length and interception depth</i></li> <li><i>hole length.</i></li> </ul> </li> <li><i>If the exclusion of this information is justified on the basis that the information is not Material and this exclusion does not detract from the understanding of the report, the Competent Person should clearly explain why this is the case.</i></li> </ul>	<ul style="list-style-type: none"> <li>All drill information being reported as part of this announcement can be found on the Company’s website and specifically the announcements released to the ASX on 14 Sep 2021, 27 Sep 2021, 19 Oct 2021, 3 Nov 2021, 9 Nov 2021, 17 Nov 2021, 11 Jan 2022, 28 Jan 2022, 2 Mar 2022, and 22 March 2023.</li> <li>Assays were conducted at ALS Laboratory in Perth, WA. DTT and wLIMS testwork was conducted by ALS Iron Ore facility in Perth, WA.</li> <li>Only data from Bekisopa South was used for this Mineral Resource estimate. No data from Bekisopa South was excluded.</li> <li>A plan of the drillholes at Bekisopa South is contained in the main body of the report.</li> </ul>
<i>Data aggregation methods</i>	<ul style="list-style-type: none"> <li><i>In reporting Exploration Results, weighting averaging techniques, maximum and/or minimum grade truncations (eg cutting of high grades) and cut-off grades are</i></li> </ul>	<ul style="list-style-type: none"> <li>No top-cuts to the data were required.</li> <li>No metal equivalent equations were used during the Mineral Resource estimation procedure or reporting.</li> <li>Samples were composited to 1m lengths during the Mineral Resource estimation procedure to ensure a consistent level of support during the estimation process.</li> </ul>

For personal use only

Criteria	JORC Code explanation	Commentary
	<p><i>usually Material and should be stated.</i></p> <ul style="list-style-type: none"> <li>• <i>Where aggregate intercepts incorporate short lengths of high grade results and longer lengths of low grade results, the procedure used for such aggregation should be stated and some typical examples of such aggregations should be shown in detail.</i></li> <li>• <i>The assumptions used for any reporting of metal equivalent values should be clearly stated.</i></li> </ul>	
<i>Relationship between mineralisation widths and intercept lengths</i>	<ul style="list-style-type: none"> <li>• <i>These relationships are particularly important in the reporting of Exploration Results.</i></li> <li>• <i>If the geometry of the mineralisation with respect to the drill hole angle is known, its nature should be reported.</i></li> <li>• <i>If it is not known and only the down hole lengths are reported, there should be a clear statement to this effect (eg 'down hole length, true width not known').</i></li> </ul>	<ul style="list-style-type: none"> <li>• DSO mineralisation is interpreted to be tabular and horizontal therefore vertical drilling is orthogonal to mineralisation.</li> <li>• Deeper mineralisation is interpreted to dip to the west, therefore drillholes have been drilled with a easty dip to intersect mineralisation orthogonally.</li> </ul>
<i>Diagrams</i>	<ul style="list-style-type: none"> <li>• <i>Appropriate maps and sections (with scales) and tabulations of intercepts should be included for any significant discovery being reported These should include, but not be limited to a plan view of drill hole collar locations and appropriate sectional views.</i></li> </ul>	<ul style="list-style-type: none"> <li>• Appropriate data tabulations are included in the main body of the report.</li> </ul>

For personal use only

Criteria	JORC Code explanation	Commentary
<i>Balanced reporting</i>	<ul style="list-style-type: none"> <li>Where comprehensive reporting of all Exploration Results is not practicable, representative reporting of both low and high grades and/or widths should be practiced to avoid misleading reporting of Exploration Results.</li> </ul>	<ul style="list-style-type: none"> <li>Statistics of drill hole grades used in the MRE are contained in the main body of the report.</li> </ul>
<i>Other substantive exploration data</i>	<ul style="list-style-type: none"> <li>Other exploration data, if meaningful and material, should be reported including (but not limited to): geological observations; geophysical survey results; geochemical survey results; bulk samples – size and method of treatment; metallurgical test results; bulk density, groundwater, geotechnical and rock characteristics; potential deleterious or contaminating substances.</li> </ul>	<ul style="list-style-type: none"> <li>Akora has completed ground geophysical surveys using international suppliers. This clearly defines the iron rich mineralisation and was used as a guide to planning drillholes.</li> </ul>
<i>Further work</i>	<ul style="list-style-type: none"> <li>The nature and scale of planned further work (eg tests for lateral extensions or depth extensions or large-scale step-out drilling).</li> <li>Diagrams clearly highlighting the areas of possible extensions, including the main geological interpretations and future drilling areas, provided this information is not commercially sensitive.</li> </ul>	<ul style="list-style-type: none"> <li>WAI understands that Akora is planning to undertake some additional short drillholes into the DSO zones at Bekisopa South during 2023. WAI is not aware of any further details of this.</li> </ul>

### Section 3 Estimation and Reporting of Mineral Resources

Criteria	JORC Code explanation	Commentary
<i>Database integrity</i>	<ul style="list-style-type: none"> <li>Measures taken to ensure that data has not been corrupted by, for example, transcription or keying errors, between its initial collection and its use for Mineral Resource estimation purposes.</li> <li>Data validation procedures used.</li> </ul>	<ul style="list-style-type: none"> <li>Validation of the database is undertaken by Akora personnel and its consultants/contractors.</li> <li>The database consists of individual Microsoft Excel sheets containing all relevant exploration data.</li> <li>All data is manually entered to Microsoft Excel sheets from hard copy logging, or in cases of geophysical data, downloaded from the relevant machine and uploaded to the database.</li> <li>Database validation conducted by WAI for this MRE included: <ul style="list-style-type: none"> <li>Ensuring drillhole collars have valid coordinates, coincide within expected limits and correlate with topographical surfaces;</li> <li>Checking for the presence of duplicate drillhole collar IDs and coordinates;</li> <li>Ensuring all holes have valid downhole surveys and have consistent values;</li> <li>Ensuring assays, density measurements or logging information is present.</li> <li>Checking for overlapping, duplicate, or absent assay values;</li> <li>Checking minimum and maximum values for grades and density to ensure they are within expected limits;</li> <li>Identify sample intervals where grade has been recorded over an excessive length;</li> <li>Assessing for inconsistencies in spelling or coding to ensure consistency in data review.</li> </ul> </li> </ul>
<i>Site visits</i>	<ul style="list-style-type: none"> <li>Comment on any site visits undertaken by the Competent Person and the outcome of those visits.</li> <li>If no site visits have been undertaken indicate why this is the case.</li> </ul>	<ul style="list-style-type: none"> <li>A site visit was conducted by Mr Robin Kelly on the 7<sup>th</sup> May, 2023. During the visit, Bekisopa North, Central and South zones were visited, outcrops observed, DSO scree observed and select drill collars visited and their co-ordinates verified.</li> <li>Mr Robin Kelly also visited the core storage facility in Antananarivo on the 10<sup>th</sup> May, 2023. Multiple drillholes were observed and original logs and assay results briefly compared. Drillholes observed included: <ul style="list-style-type: none"> <li>BEKD044</li> <li>BEKD045</li> <li>BEKD067</li> <li>BEKD092</li> <li>BEK121</li> <li>BEK126</li> <li>BEKD132</li> </ul> </li> </ul>
<i>Geological interpretation</i>	<ul style="list-style-type: none"> <li>Confidence in (or conversely, the uncertainty of) the geological interpretation of the mineral deposit.</li> </ul>	<ul style="list-style-type: none"> <li>The broad geological interpretation of the Bekisopa deposit is relatively straightforward and moderately constrained by drilling, surface mapping and the high amplitude airborne and ground</li> </ul>

For personal use only

Criteria	JORC Code explanation	Commentary
	<ul style="list-style-type: none"> <li>• <i>Nature of the data used and of any assumptions made.</i></li> <li>• <i>The effect, if any, of alternative interpretations on Mineral Resource estimation.</i></li> <li>• <i>The use of geology in guiding and controlling Mineral Resource estimation.</i></li> <li>• <i>The factors affecting continuity both of grade and geology.</i></li> </ul>	<p>magnetic anomalies.</p> <ul style="list-style-type: none"> <li>• DSO material is relatively discrete and well constrained.</li> <li>• The main iron mineralisation comprises a series of parallel layers of massive magnetite (+/-hematite), within magnetite bearing gneiss. Mineralisation appears to be stratabound and is thought to be a replacement of carbonate/calc silicate units intermixed with gneissic-schist material.</li> <li>• The deposit is thought to be replacive (skarn), the distribution of original calc-silicate host lithology will be a major control of grade continuity. Skarns are notorious for variable grade continuity.</li> <li>• Additional work is required to further the understanding of the geological model, structural interpretation and grade variability at Bekisopa South. In addition, the relationship between the western and eastern DSO zones is currently unknown and further geological studies will be required to determine this.</li> <li>• WAI generated solid wireframes for the DSO zones based on a nominal cut-off grade of 58% Fe. DSO material is predominantly hosted in the regolith, although minor amounts of less weathered material have also been captured within these wireframe zones.</li> <li>• For the Green Steel zone, a 25% cut-off grade was used to define the wireframes of the mineralisation. Due to the varied lithological nature of the Fe mineralisation within these interbedded metamorphic units, modelling was completed using assay values only.</li> </ul>
<i>Dimensions</i>	<ul style="list-style-type: none"> <li>• <i>The extent and variability of the Mineral Resource expressed as length (along strike or otherwise), plan width, and depth below surface to the upper and lower limits of the Mineral Resource.</i></li> </ul>	<ul style="list-style-type: none"> <li>• The Mineral Resource Estimate was completed on the Bekisopa South target only.</li> <li>• The mineralisation at Bekisopa South consists of two near surface DSO mineralisation packages with a deeper zone of mineralisation termed the "Green Steel" zone . <ul style="list-style-type: none"> <li>○ DSO West – strike length of 675m, width of 25-200m and depth of up to 25m, orientated North to South and is flat lying.</li> <li>○ DSO East – strike length of 1,000m, width of 150-320m and depth of up to 30m, orientated Northeast to Southwest and dipping 5° to the northwest.</li> <li>○ Green Steel zone – strike length of 750m, width of 320-575m and depth of up to 210m, orientated Northeast to Southwest and dipping 20° to the northwest.</li> </ul> </li> </ul>
<i>Estimation and modelling techniques</i>	<ul style="list-style-type: none"> <li>• <i>The nature and appropriateness of the estimation technique(s) applied and key assumptions, including treatment of extreme grade values, domaining, interpolation parameters and maximum distance of extrapolation from data</i></li> </ul>	<ul style="list-style-type: none"> <li>• Variogram models for Fe, Al<sub>2</sub>O<sub>3</sub>, Mn, P, S, SiO<sub>2</sub> and TiO<sub>2</sub> were constructed based on composite data after normal score transformation, however, well-structured variograms were not able to be created.</li> <li>• Inverse Distance Weighting ("IDW") was therefore used as the principal estimation methodology. Nearest Neighbour estimates were carried out for validation purposes.</li> <li>• A block size of 20m (X) x 20m (Y) x5m (Z) was used for grade estimation. The smallest drill spacing at Bekisopa South is 50m x 50m in the DSO zones. Estimation was carried out into parent cells only. Search</li> </ul>

For personal use only

Criteria	JORC Code explanation	Commentary																																																																																								
	<p><i>points. If a computer assisted estimation method was chosen include a description of computer software and parameters used.</i></p> <ul style="list-style-type: none"> <li><i>The availability of check estimates, previous estimates and/or mine production records and whether the Mineral Resource estimate takes appropriate account of such data.</i></li> <li><i>The assumptions made regarding recovery of by-products.</i></li> <li><i>Estimation of deleterious elements or other non-grade variables of economic significance (eg sulphur for acid mine drainage characterisation).</i></li> <li><i>In the case of block model interpolation, the block size in relation to the average sample spacing and the search employed.</i></li> <li><i>Any assumptions behind modelling of selective mining units.</i></li> <li><i>Any assumptions about correlation between variables.</i></li> <li><i>Description of how the geological interpretation was used to control the resource estimates.</i></li> <li><i>Discussion of basis for using or not using grade cutting or capping.</i></li> <li><i>The process of validation, the checking process used, the comparison of model data to drill hole data, and use of reconciliation data if available.</i></li> </ul>	<p>parameters used in the estimation are detailed in the main body of the report. A total of 2,145 composites were used in the estimation of MINDOMs 1 to 7.</p> <table border="1" style="width: 100%; border-collapse: collapse; text-align: center;"> <thead> <tr> <th colspan="8">Estimation Parameters</th> </tr> <tr> <th rowspan="2">MINDOM</th> <th rowspan="2">Search</th> <th colspan="3">Search Distance (m)</th> <th colspan="2">Composites</th> <th>Drillholes</th> </tr> <tr> <th>Down Dip</th> <th>Along Strike</th> <th>Across Strike</th> <th>Minimum</th> <th>Maximum</th> <th>Minimum</th> </tr> </thead> <tbody> <tr> <td rowspan="3">1</td> <td>1<sup>st</sup></td> <td>50</td> <td>75</td> <td>10</td> <td>11</td> <td>22</td> <td>2</td> </tr> <tr> <td>2<sup>nd</sup></td> <td>100</td> <td>150</td> <td>20</td> <td>11</td> <td>22</td> <td>2</td> </tr> <tr> <td>3<sup>rd</sup></td> <td>150</td> <td>225</td> <td>30</td> <td>2</td> <td>20</td> <td>1</td> </tr> <tr> <td rowspan="3">2</td> <td>1<sup>st</sup></td> <td>50</td> <td>75</td> <td>10</td> <td>11</td> <td>22</td> <td>2</td> </tr> <tr> <td>2<sup>nd</sup></td> <td>100</td> <td>150</td> <td>20</td> <td>11</td> <td>22</td> <td>2</td> </tr> <tr> <td>3<sup>rd</sup></td> <td>150</td> <td>225</td> <td>30</td> <td>2</td> <td>20</td> <td>1</td> </tr> <tr> <td rowspan="3">3</td> <td>1<sup>st</sup></td> <td>50</td> <td>75</td> <td>15</td> <td>11</td> <td>22</td> <td>2</td> </tr> <tr> <td>2<sup>nd</sup></td> <td>100</td> <td>150</td> <td>30</td> <td>11</td> <td>22</td> <td>2</td> </tr> <tr> <td>3<sup>rd</sup></td> <td>150</td> <td>225</td> <td>45</td> <td>2</td> <td>20</td> <td>1</td> </tr> </tbody> </table> <p>Notes:  MINDOM 1 orientation – down dip: east-west; along strike: north-south;  MINDOM 2 orientation – down dip: -5 degree dip to 305 degrees azimuth; along strike: 35 degrees azimuth;  MINDOM 2 orientation – down dip: -20 degree dip to 305 degrees azimuth; along strike: 35 degrees azimuth;  (MINDOM 1 search used for MINDOMs 5, 6 and 7)  (MINDOM 2 search used for MINDOM 4)  Maxkey of 10 composites per drillhole</p> <ul style="list-style-type: none"> <li>Grades were estimated into the defined mineralised zones (MINDOM keyfield) which were treated as hard boundaries.</li> <li>Density values (derived from the regression of Fe grades after subdivision by weathering type) were estimated into the mineralised zones based on weathering type (DENSDOM keyfield).</li> <li>Grades and density values were estimated into the block model using Datamine software.</li> <li>Davis Tube Test (“DTT”) results of the recovered magnetic fraction were included in the block model for the Green Steel zone (MINDOM 3) by regressing the estimated Fe block grades based on weathering type. Regression formulas were derived for each weathering type using a total of 1,068 DTT results with corresponding Fe results.</li> <li>Potentially deleterious elements (Al<sub>2</sub>O<sub>3</sub>, Mn, P, SiO<sub>2</sub> and TiO<sub>2</sub>) were estimated into the block model. Sulphur (S) was not estimated as an upper assay detection limit of 5.0% S is present in the assays in the database. It is recommended that these values are re-assayed using a different method with a higher</li> </ul>	Estimation Parameters								MINDOM	Search	Search Distance (m)			Composites		Drillholes	Down Dip	Along Strike	Across Strike	Minimum	Maximum	Minimum	1	1 <sup>st</sup>	50	75	10	11	22	2	2 <sup>nd</sup>	100	150	20	11	22	2	3 <sup>rd</sup>	150	225	30	2	20	1	2	1 <sup>st</sup>	50	75	10	11	22	2	2 <sup>nd</sup>	100	150	20	11	22	2	3 <sup>rd</sup>	150	225	30	2	20	1	3	1 <sup>st</sup>	50	75	15	11	22	2	2 <sup>nd</sup>	100	150	30	11	22	2	3 <sup>rd</sup>	150	225	45	2	20	1
Estimation Parameters																																																																																										
MINDOM	Search	Search Distance (m)			Composites		Drillholes																																																																																			
		Down Dip	Along Strike	Across Strike	Minimum	Maximum	Minimum																																																																																			
1	1 <sup>st</sup>	50	75	10	11	22	2																																																																																			
	2 <sup>nd</sup>	100	150	20	11	22	2																																																																																			
	3 <sup>rd</sup>	150	225	30	2	20	1																																																																																			
2	1 <sup>st</sup>	50	75	10	11	22	2																																																																																			
	2 <sup>nd</sup>	100	150	20	11	22	2																																																																																			
	3 <sup>rd</sup>	150	225	30	2	20	1																																																																																			
3	1 <sup>st</sup>	50	75	15	11	22	2																																																																																			
	2 <sup>nd</sup>	100	150	30	11	22	2																																																																																			
	3 <sup>rd</sup>	150	225	45	2	20	1																																																																																			

For personal use only

Criteria	JORC Code explanation	Commentary																																																			
		<p>detection limit prior to estimation of S in the block model.</p> <ul style="list-style-type: none"> <li>No top-cutting was applied as no extreme values were identified during the geostatistical review.</li> <li>Estimation of grades and density within the block model was verified visually and appears to represent the grades within the drillholes and composites. WAI also completed a statistical analysis of the block model comparison against the composited drillhole data, along with Swath plots, which show a good correlation with the original drillhole data.</li> <li>The deposit has not been mined and so there is no reconciliation data.</li> </ul>																																																			
Moisture	<ul style="list-style-type: none"> <li>Whether the tonnages are estimated on a dry basis or with natural moisture, and the method of determination of the moisture content.</li> </ul>	<ul style="list-style-type: none"> <li>Tonnages of the Mineral Resources are estimated on a dry weight basis.</li> </ul>																																																			
Cut-off parameters	<ul style="list-style-type: none"> <li>The basis of the adopted cut-off grade(s) or quality parameters applied.</li> </ul>	<ul style="list-style-type: none"> <li>No cut-off applied for DSO.</li> <li>Cut-off grade of 36% Fe applied to the Green Steel zone to give a head grade of 45% Fe (based on the Scoping Study (October 2022)).</li> </ul>																																																			
Mining factors or assumptions	<ul style="list-style-type: none"> <li>Assumptions made regarding possible mining methods, minimum mining dimensions and internal (or, if applicable, external) mining dilution. It is always necessary as part of the process of determining reasonable prospects for eventual economic extraction to consider potential mining methods, but the assumptions made regarding mining methods and parameters when estimating Mineral Resources may not always be rigorous. Where this is the case, this should be reported with an explanation of the basis of the mining assumptions made.</li> </ul>	<ul style="list-style-type: none"> <li>The MRE has been constrained by an open pit optimisation based on technical and indicative processing costs and long-term product pricing parameters as shown below (based on the October 2022 Scoping Study).</li> </ul> <table border="1" data-bbox="1137 912 1975 1378"> <thead> <tr> <th colspan="4">Akora MRE Constraint Optimisation Parameters</th> </tr> <tr> <th>Parameter</th> <th>Unit</th> <th>DSO Zones</th> <th>Green Steel Zone</th> </tr> </thead> <tbody> <tr> <td>Mining Cost Ore</td> <td>US\$/t</td> <td>2*</td> <td>3*</td> </tr> <tr> <td>Mining Cost Waste</td> <td>US\$/t</td> <td>2*</td> <td>3*</td> </tr> <tr> <td>Re-handling Cost</td> <td>US\$/t</td> <td colspan="2">1.00</td> </tr> <tr> <td rowspan="2">Processing cost</td> <td>US\$/t mined</td> <td>3*</td> <td>10*</td> </tr> <tr> <td>US\$/t conc</td> <td>3*</td> <td>27*</td> </tr> <tr> <td>Transport &amp; Logistics</td> <td>US\$/t conc</td> <td colspan="2">25.00</td> </tr> <tr> <td>G&amp;A</td> <td>US\$/t ore</td> <td colspan="2">0.50</td> </tr> <tr> <td>Royalty Cost</td> <td>%</td> <td colspan="2">4</td> </tr> <tr> <td>Metallurgical Recovery</td> <td>%</td> <td>100</td> <td>54</td> </tr> <tr> <td>Concentrate Grade</td> <td>%Fe</td> <td>67</td> <td>67</td> </tr> <tr> <td>Discount Rate</td> <td>%</td> <td colspan="2">10</td> </tr> </tbody> </table>	Akora MRE Constraint Optimisation Parameters				Parameter	Unit	DSO Zones	Green Steel Zone	Mining Cost Ore	US\$/t	2*	3*	Mining Cost Waste	US\$/t	2*	3*	Re-handling Cost	US\$/t	1.00		Processing cost	US\$/t mined	3*	10*	US\$/t conc	3*	27*	Transport & Logistics	US\$/t conc	25.00		G&A	US\$/t ore	0.50		Royalty Cost	%	4		Metallurgical Recovery	%	100	54	Concentrate Grade	%Fe	67	67	Discount Rate	%	10	
Akora MRE Constraint Optimisation Parameters																																																					
Parameter	Unit	DSO Zones	Green Steel Zone																																																		
Mining Cost Ore	US\$/t	2*	3*																																																		
Mining Cost Waste	US\$/t	2*	3*																																																		
Re-handling Cost	US\$/t	1.00																																																			
Processing cost	US\$/t mined	3*	10*																																																		
	US\$/t conc	3*	27*																																																		
Transport & Logistics	US\$/t conc	25.00																																																			
G&A	US\$/t ore	0.50																																																			
Royalty Cost	%	4																																																			
Metallurgical Recovery	%	100	54																																																		
Concentrate Grade	%Fe	67	67																																																		
Discount Rate	%	10																																																			

For personal use only

Criteria	JORC Code explanation	Commentary																		
		<table border="1" data-bbox="1137 300 1975 496"> <tr> <td>Overall Pit Slope Angles</td> <td>°</td> <td>40</td> </tr> <tr> <td>Mining Recovery</td> <td>%</td> <td>0</td> </tr> <tr> <td>Mining Dilution</td> <td>%</td> <td>0</td> </tr> <tr> <td>62% Fe Conc Price</td> <td>US\$/t conc</td> <td>110*</td> </tr> <tr> <td>65% Fe Conc Price</td> <td>US\$/t conc</td> <td>135*</td> </tr> <tr> <td>67% Fe Conc Price</td> <td>US\$/t conc</td> <td>150*</td> </tr> </table> <p data-bbox="1146 501 1868 523">* Estimated long-term rounded costs and product prices for optimisation purposes</p> <ul data-bbox="972 531 2141 687" style="list-style-type: none"> <li>The low grade mineralized zones (MINDOMs 4, 5, 6 and 7) and the highly weathered portion of the Green Steel zone (MINDOM 3) were also included in the optimization process and used the parameters for the Green Steel zone shown in the table above. These zones, however, were excluded from the final Mineral Resource statement as they are not currently considered by Akora as part of the Bekisopa Project due to lower Fe grades or higher levels of impurities.</li> </ul>	Overall Pit Slope Angles	°	40	Mining Recovery	%	0	Mining Dilution	%	0	62% Fe Conc Price	US\$/t conc	110*	65% Fe Conc Price	US\$/t conc	135*	67% Fe Conc Price	US\$/t conc	150*
Overall Pit Slope Angles	°	40																		
Mining Recovery	%	0																		
Mining Dilution	%	0																		
62% Fe Conc Price	US\$/t conc	110*																		
65% Fe Conc Price	US\$/t conc	135*																		
67% Fe Conc Price	US\$/t conc	150*																		
<p><i>Metallurgical factors or assumptions</i></p>	<ul style="list-style-type: none"> <li><i>The basis for assumptions or predictions regarding metallurgical amenability. It is always necessary as part of the process of determining reasonable prospects for eventual economic extraction to consider potential metallurgical methods, but the assumptions regarding metallurgical treatment processes and parameters made when reporting Mineral Resources may not always be rigorous. Where this is the case, this should be reported with an explanation of the basis of the metallurgical assumptions made.</i></li> </ul>	<ul style="list-style-type: none"> <li>The DSO will be processed by crushing and screening to produce conventional lump and fines products.</li> <li>The green steel material flowsheet (based on the October 2022 Scoping Study) includes: <ul style="list-style-type: none"> <li>a) Wet grinding to 75-micron size and wet high intensity magnetic separation;</li> <li>b) Davis Tube Testing (DTT) on assay pulp ground samples, at a typical P80 of 75 microns, delivered iron concentrate grades averaging 68.4% Fe from head grades &gt;45% Fe and with a mass recovery of 54% for a specific composite sample.</li> </ul> </li> <li>An updated Scoping Study is planned by Akora in 2023 and will incorporate additional DTT recovery information not included in the October 2022 Scoping Study.</li> </ul>																		
<p><i>Environmental factors or assumptions</i></p>	<ul style="list-style-type: none"> <li><i>Assumptions made regarding possible waste and process residue disposal options. It is always necessary as part of the process of determining reasonable prospects for eventual economic extraction to consider the</i></li> </ul>	<ul style="list-style-type: none"> <li>The deposit lies within flat to lightly undulating, isolated open country in south central rural Madagascar, predominately scrubby grassland with occasional small trees.</li> <li>There are large flat areas for waste and tailings disposal.</li> <li>A small number of creeks with only seasonal flows are also present.</li> </ul>																		

For personal use only

Criteria	JORC Code explanation	Commentary
	<p><i>potential environmental impacts of the mining and processing operation. While at this stage the determination of potential environmental impacts, particularly for a greenfields project, may not always be well advanced, the status of early consideration of these potential environmental impacts should be reported. Where these aspects have not been considered this should be reported with an explanation of the environmental assumptions made.</i></p>	<ul style="list-style-type: none"> <li>WAI is not aware of any waste storage, environmental or permitting issues that prevent the reporting of a Mineral Resource Estimate for the Bekisopa South Iron deposit.</li> </ul>
<p><b>Bulk density</b></p>	<ul style="list-style-type: none"> <li><i>Whether assumed or determined. If assumed, the basis for the assumptions. If determined, the method used, whether wet or dry, the frequency of the measurements, the nature, size and representativeness of the samples.</i></li> <li><i>The bulk density for bulk material must have been measured by methods that adequately account for void spaces (vugs, porosity, etc), moisture and differences between rock and alteration zones within the deposit.</i></li> <li><i>Discuss assumptions for bulk density estimates used in the evaluation process of the different materials.</i></li> </ul>	<ul style="list-style-type: none"> <li>Density of samples from Bekisopa South was measured for both fresh rock and regolith/oxidised material on selected sections of core ranging in length between 10cm to 15cm.</li> <li>Samples from fresh rock were measured using the Archimedes Principle (1,448 measurements) and samples from weathered/oxidised rock was measured by Calliper Vernier (2,151 measurements) totally at 3,599 measurements.</li> <li>Voids are rare in the fresh rock material but are more prevalent in the regolith and this requires further testwork to confirm the original density value.</li> <li>Regression equations were developed based on the relationship between Fe grade and density which was subsequently estimated into the block model as detailed in estimation and modelling techniques section. The regression equations used are as follows:             <ul style="list-style-type: none"> <li>Domain 110: <math>(0.062 * H\_Fe\_pct) - 0.276</math></li> <li>Domain 120: <math>(0.05 * H\_Fe\_pct) + 1.13</math></li> <li>Domain 210 &lt; 40% Fe: <math>(0.014 * H\_Fe\_pct) + 1.475</math></li> <li>Domain 210 40%-60% Fe: <math>(0.032 * H\_Fe\_pct) + 0.81</math></li> <li>Domain 210 &gt;60%: <math>(0.175 * H\_Fe\_pct) - 7.451</math></li> <li>Domain 220 &lt;60%: <math>(0.04 * H\_Fe\_pct) + 0.613</math></li> <li>Domain 220 &gt;60%: <math>(0.172 * H\_Fe\_pct) - 7.455</math></li> <li>Domain 310: <math>(0.019 * H\_Fe\_pct) + 1.603</math></li> <li>Domain 320: <math>(0.031 * H\_Fe\_pct) + 2.281</math></li> <li>Domain 330: <math>0.038 * H\_Fe\_pct + 2.7</math></li> </ul> </li> </ul>

For personal use only

Criteria	JORC Code explanation	Commentary
<i>Classification</i>	<ul style="list-style-type: none"> <li><i>The basis for the classification of the Mineral Resources into varying confidence categories.</i></li> <li><i>Whether appropriate account has been taken of all relevant factors (ie relative confidence in tonnage/grade estimations, reliability of input data, confidence in continuity of geology and metal values, quality, quantity and distribution of the data).</i></li> <li><i>Whether the result appropriately reflects the Competent Person's view of the deposit.</i></li> </ul>	<ul style="list-style-type: none"> <li>Mineral Resource classification was made following the guidelines of the JORC Code (2012) to Indicated and Inferred status.</li> <li>Classification was based on sample density, confidence in the geological and mineralisation continuity and reliability of the exploration database used as the basis of Mineral Resource estimation.</li> <li>Measured Mineral Resources – Despite the relatively close spaced drilling in areas of Bekisopa South, WAI believes that an absence of an overall geological and structural model precludes the classification of Measured Mineral Resources.</li> <li>Indicated Mineral Resources – Those areas of the DSO zones (MINDOMs 1 and 2) covered by exploration drillholes on a grid of 50m x 50m.</li> <li>Inferred Mineral Resources: <ul style="list-style-type: none"> <li>DSO zones (MINDOMs 1 and 2) - all remaining areas outside of the 50m x 50m spaced grid or where geological complexity is observed.</li> <li>Green Steel zone (MINDOM 3) – the moderately weathered and unweathered portions (including areas covered by deeper drillholes at a spacing of 100m x 150m) were classified as Inferred Mineral Resources. The highly weathered portion of the Green Steel zone was excluded due to higher levels of impurities associated with this zone.</li> </ul> </li> <li>The Mineral Resource Estimate classification reflects the Competent Person's view of the Bekisopa South Iron deposit.</li> </ul>
<i>Audits or reviews</i>	<ul style="list-style-type: none"> <li><i>The results of any audits or reviews of Mineral Resource estimates.</i></li> </ul>	<ul style="list-style-type: none"> <li>WAI is not aware of any audits or reviews of this or any previous Mineral Resource Estimates.</li> </ul>
<i>Discussion of relative accuracy/ confidence</i>	<ul style="list-style-type: none"> <li><i>Where appropriate a statement of the relative accuracy and confidence level in the Mineral Resource estimate using an approach or procedure deemed appropriate by the Competent Person. For example, the application of statistical or geostatistical procedures to quantify the relative accuracy of the resource within stated confidence limits, or, if such an approach is not deemed appropriate, a qualitative discussion of the factors that could</i></li> </ul>	<ul style="list-style-type: none"> <li>The relative accuracy and confidence in the Mineral Resource estimate is reflected in the reporting of the Mineral Resource as set out in the JORC Code (2012).</li> <li>Validation procedures carried out on the final block models against input sample data show good correlation.</li> <li>The statement relates to global estimates of tonnes and grade.</li> <li>Bekisopa South is a greenfield project and no production data is available.</li> </ul>

For personal use only

Criteria	JORC Code explanation	Commentary
	<p><i>affect the relative accuracy and confidence of the estimate.</i></p> <ul style="list-style-type: none"> <li><i>The statement should specify whether it relates to global or local estimates, and, if local, state the relevant tonnages, which should be relevant to technical and economic evaluation. Documentation should include assumptions made and the procedures used.</i></li> <li><i>These statements of relative accuracy and confidence of the estimate should be compared with production data, where available.</i></li> </ul>	

For personal use only

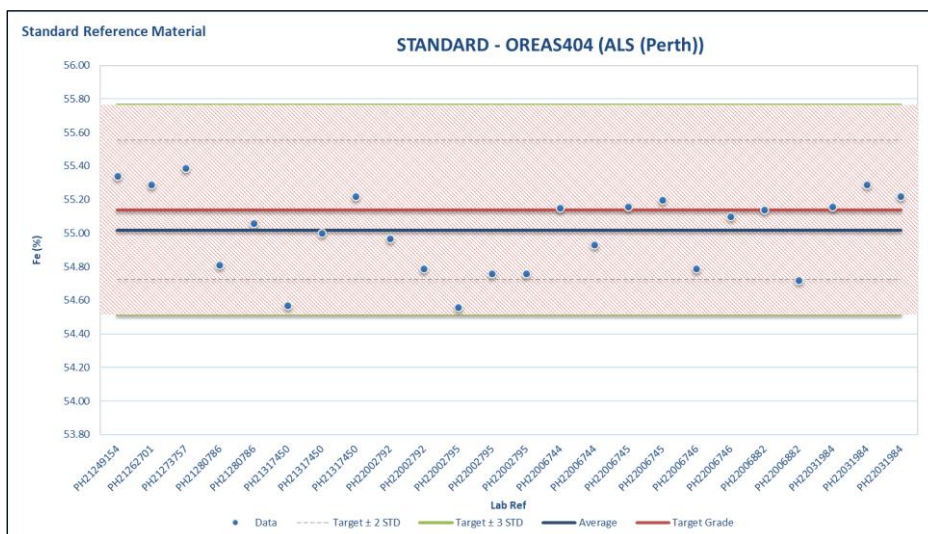
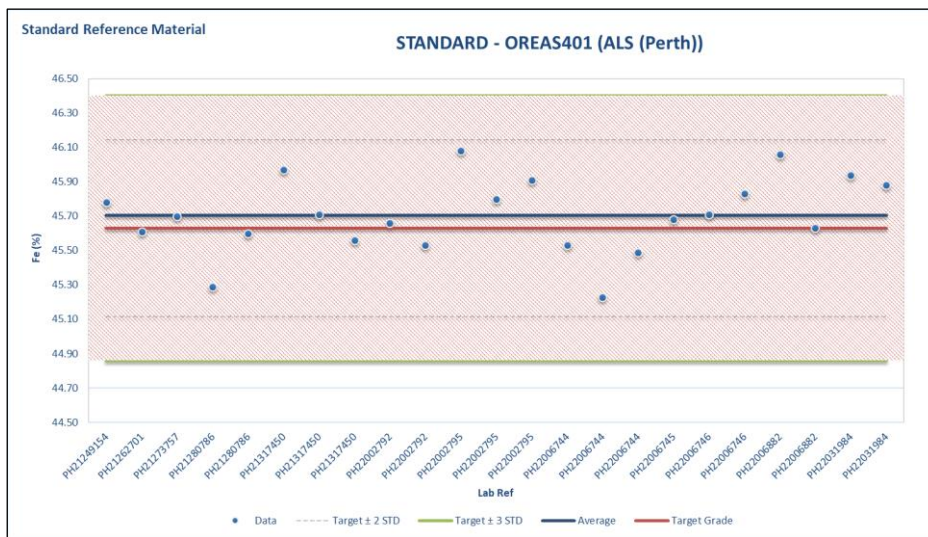
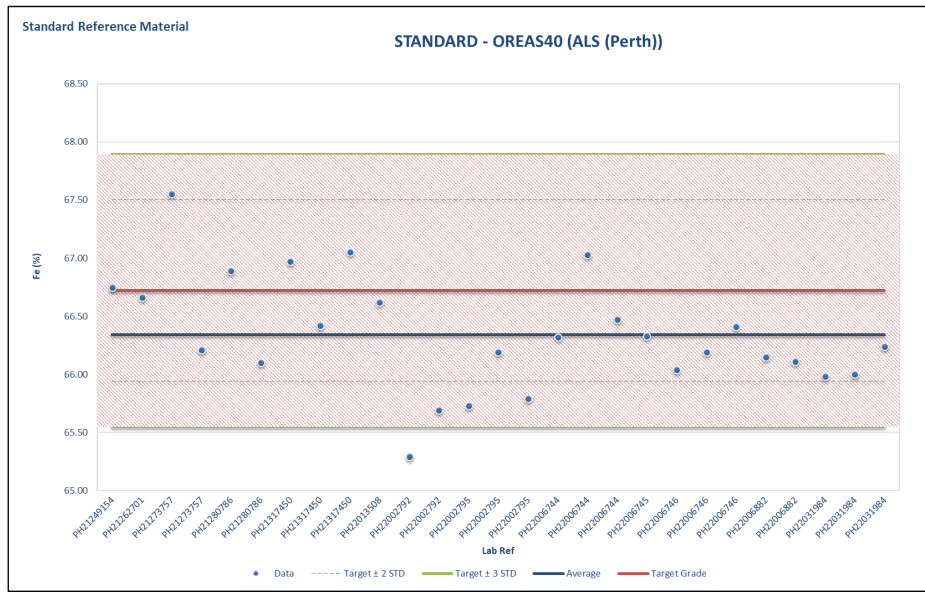
**APPENDIX 2: Certified Reference Material Analysis**

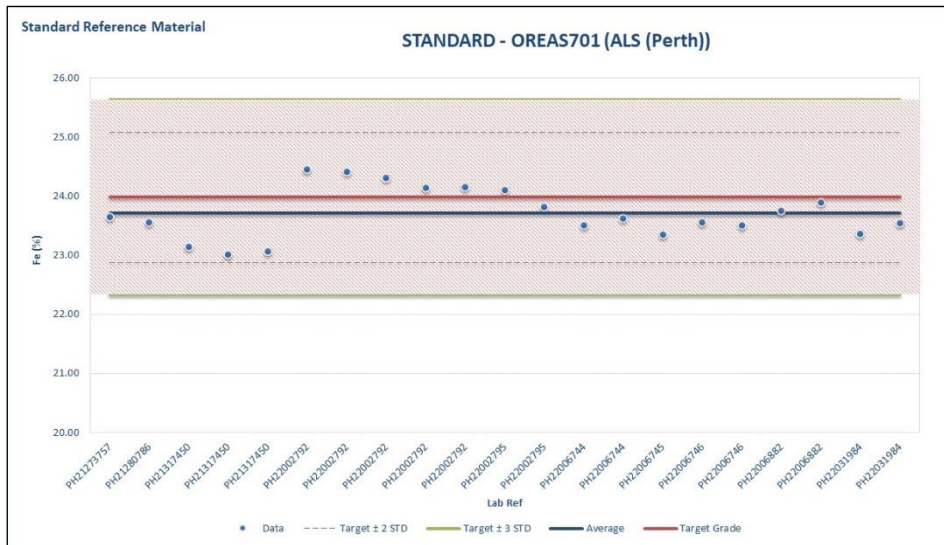
CRM Target Grades			
Type	CRMS	Reported Grade (Fe %)	Standard Deviation (Fe %)
AKORA	OREAS 40	66.72	0.39
	OREAS 401	45.63	0.257
	OREAS 404	55.14	0.208
	OREAS 701	23.98	0.549
	OREAS 464	35.55	1.569
ALS	OREAS 406	61.44	0.296
	GIOP-111	33.35	0.15
	GIOP-135	53.505	0.08
	NCSDC18014	65.87	0.08
	OREAS 402	48.41	0.298

CRM Performance 2020 (Bekisopa South)			
CRM	Assay Lab	Reported Grade (Fe%)	CRM Grade (Fe%)
OREAS 40	ALS (Ireland)	66.66	66.72
OREAS 401	ALS (Ireland)	45.91	45.63
OREAS 404	ALS (Ireland)	55.26	55.14
OREAS 701	ALS (Ireland)	23.42	23.98
OREAS 401	ALS (Perth)	45.71	45.63
OREAS 404	ALS (Perth)	55.26	55.14

Summary of Certified Reference Material Assaying in 2021 (Bekisopa South)								
Period	Laboratory	Standard	Grade Fe (%)	Number CRM Samples	Samples Outside $\pm 2$ Standard Deviations		Samples Outside $\pm 3$ Standard Deviations	
					Number Samples	% Samples	Number Samples	% Samples
2021	ALS (Perth)	OREAS 40	66.72	27	5	18.5	1	3.7
		OREAS 401	45.63	23	0	0	0	0
		OREAS 404	55.14	23	3	12.5	0	0
		OREAS 701	23.98	21	0	0	0	0

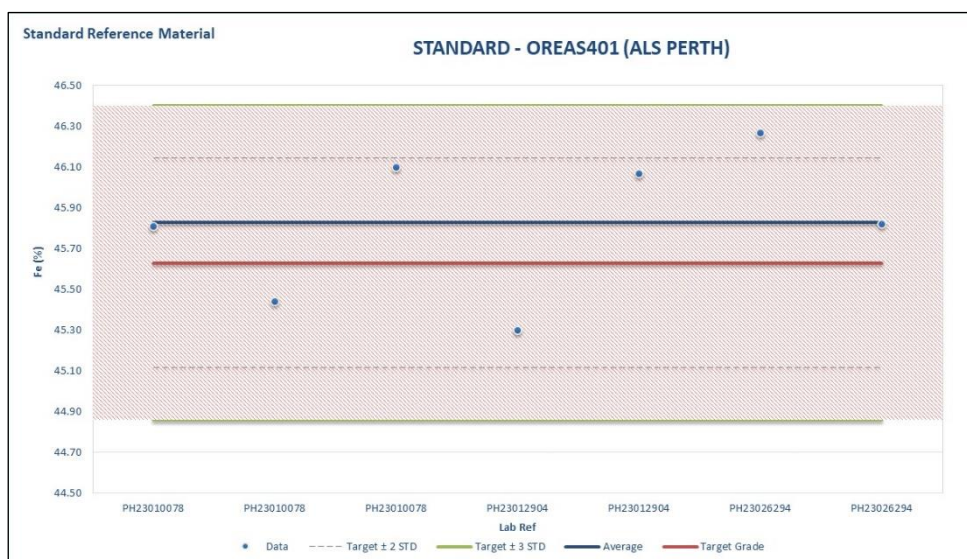
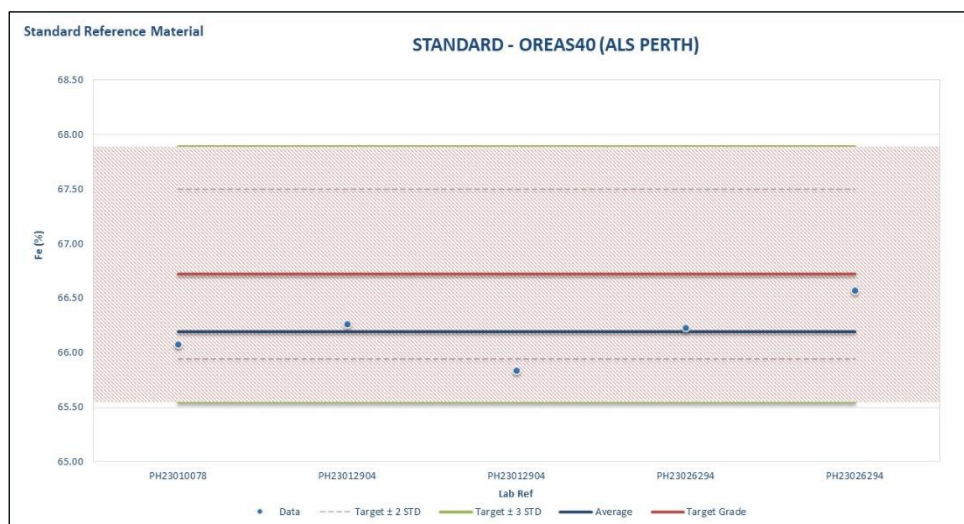
For personal use only





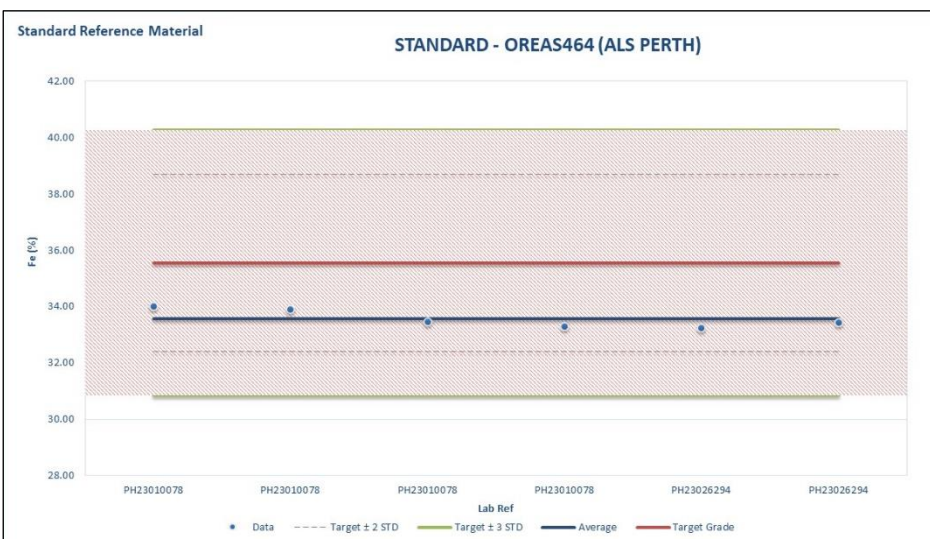
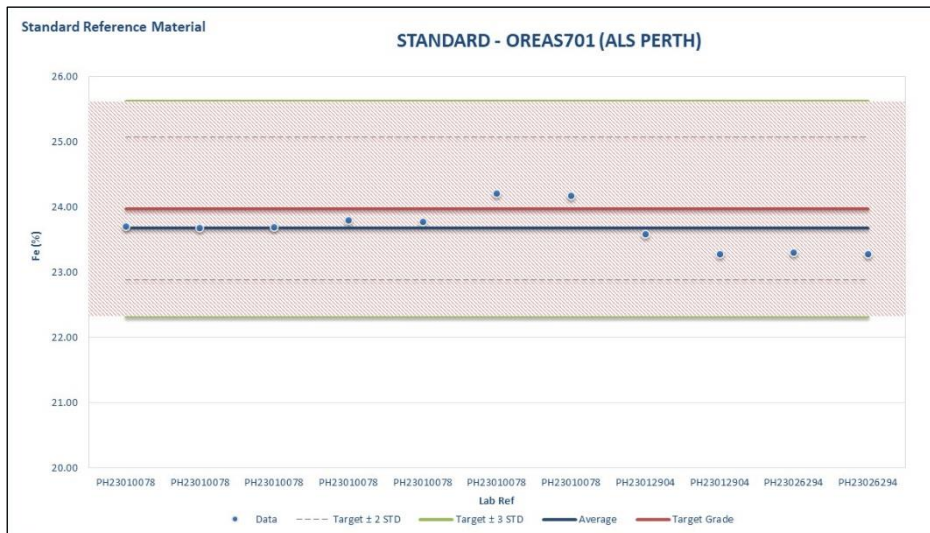
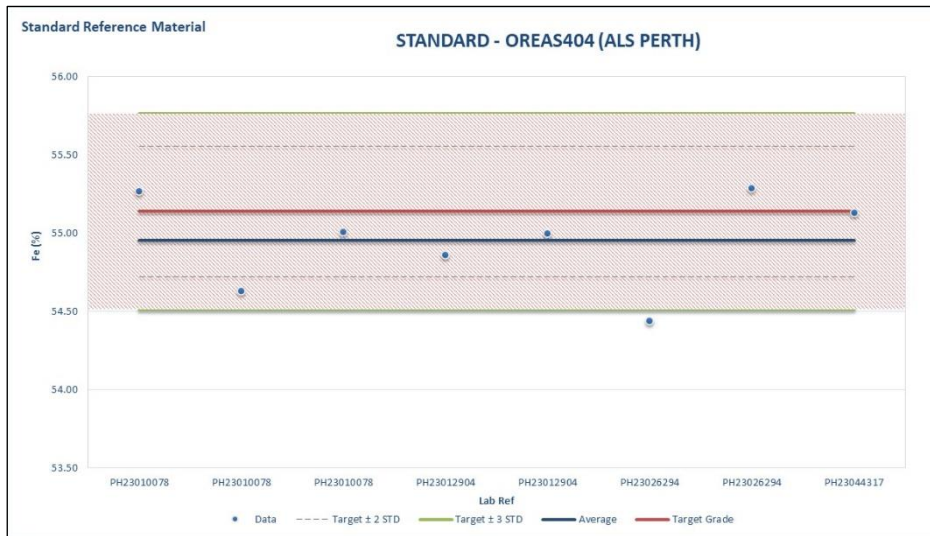
For personal use only

Summary of Certified Reference Material Results in 2022 (Bekisopa South)								
Period	Laboratory	Standard	Grade Fe (%)	Number CRM Samples	Samples Outside $\pm 2$ Standard Deviations		Samples Outside $\pm 3$ Standard Deviations	
					Number Samples	% Samples	Number Samples	% Samples
2022	ALS (Perth) Akora QAQC	OREAS 40	66.72	5	1	20.0	0	0
		OREAS 401	45.63	7	1	14.3	0	0
		OREAS 404	55.14	8	2	25.0	1	12.5
		OREAS 701	23.98	11	0	0	0	0
		OREAS 464	35.55	6	0	0	0	0
2022	ALS (Perth) Internal	OREAS 406	61.44	20	2	20.0	0	0
		GIOP 135	53.51	20	14	70	9	45
		NCSDC18014	65.87	17	11	64.7	6	35.3
		OREAS 402	23.98	12	0	0	0	0
		OREAS 401	35.55	5	0	0	0	0

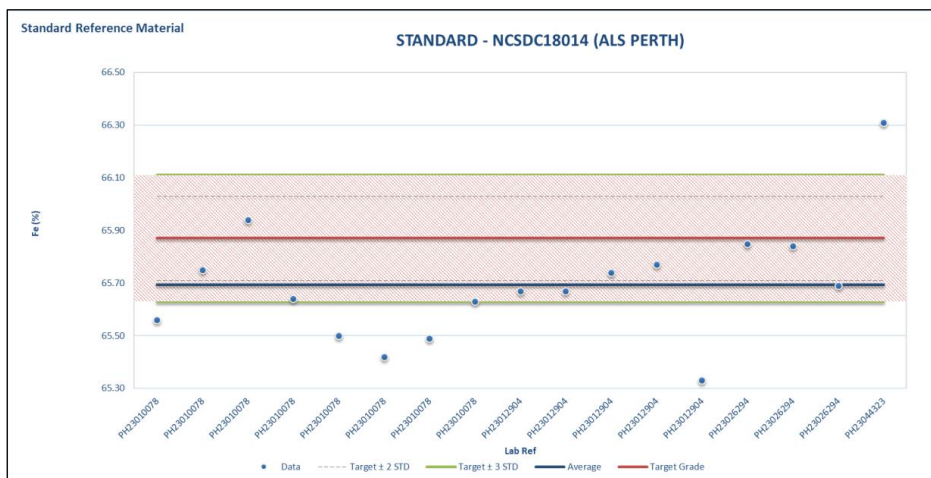
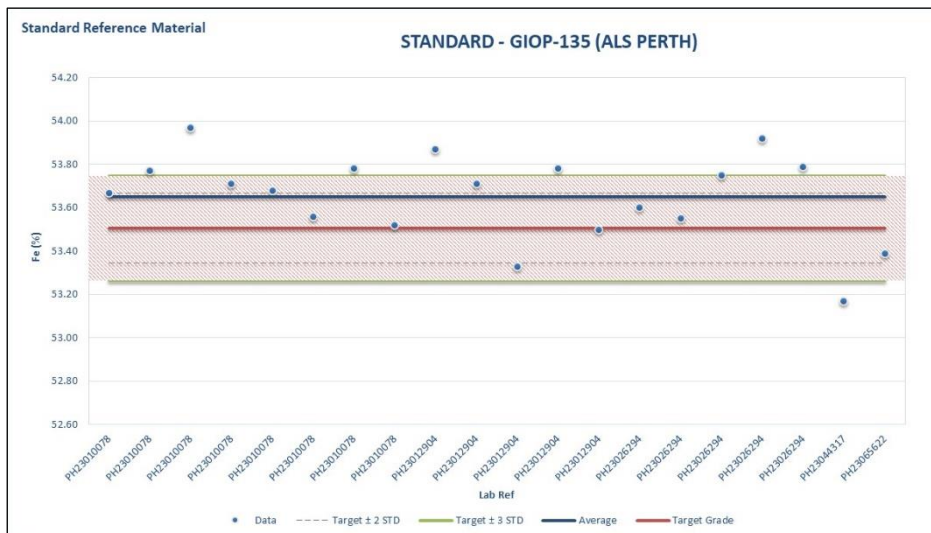
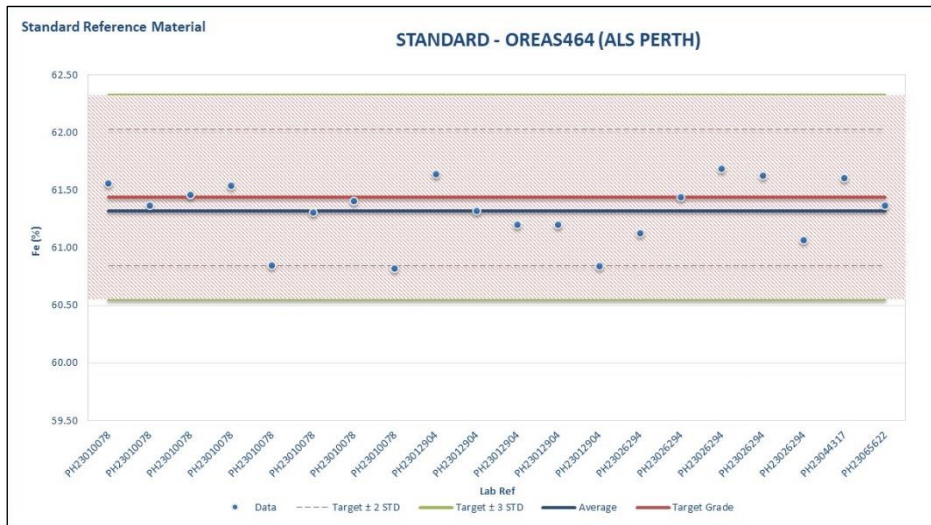


For personal use only

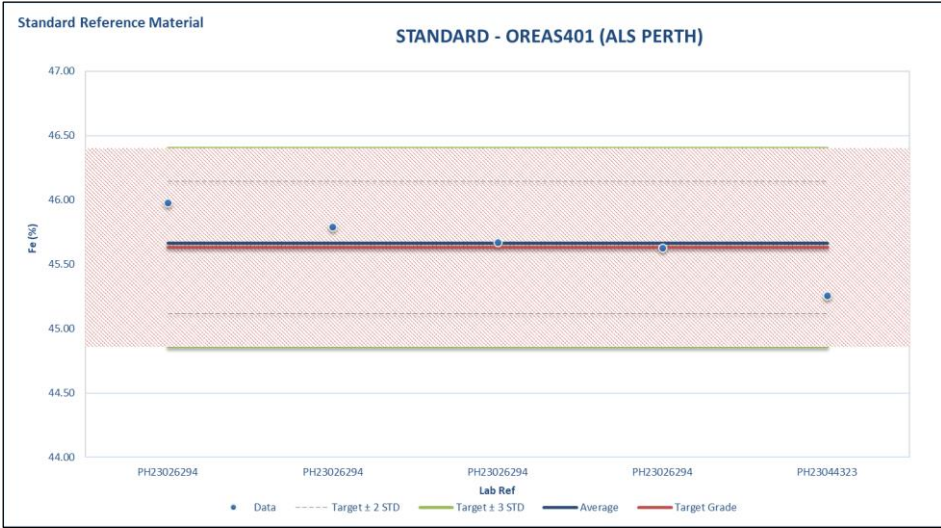
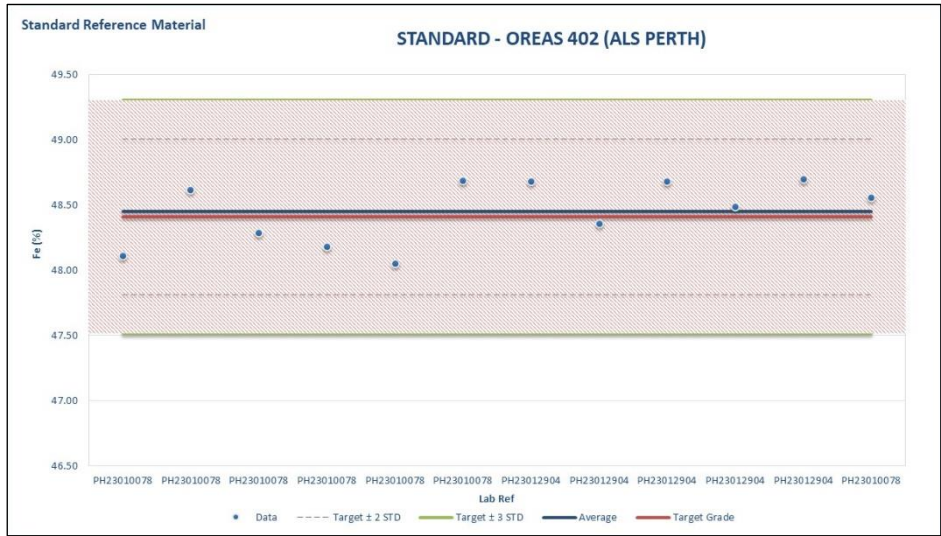
For personal use only



For personal use only



For personal use only

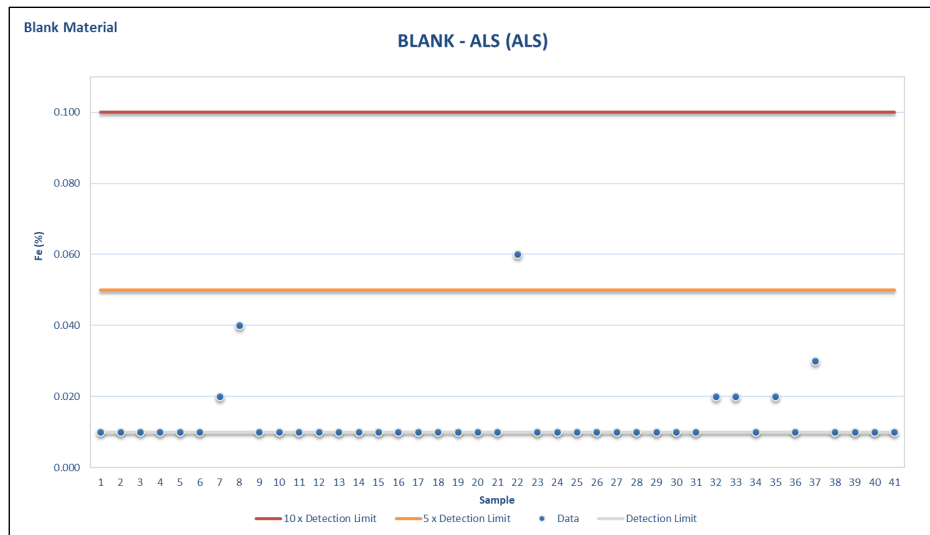
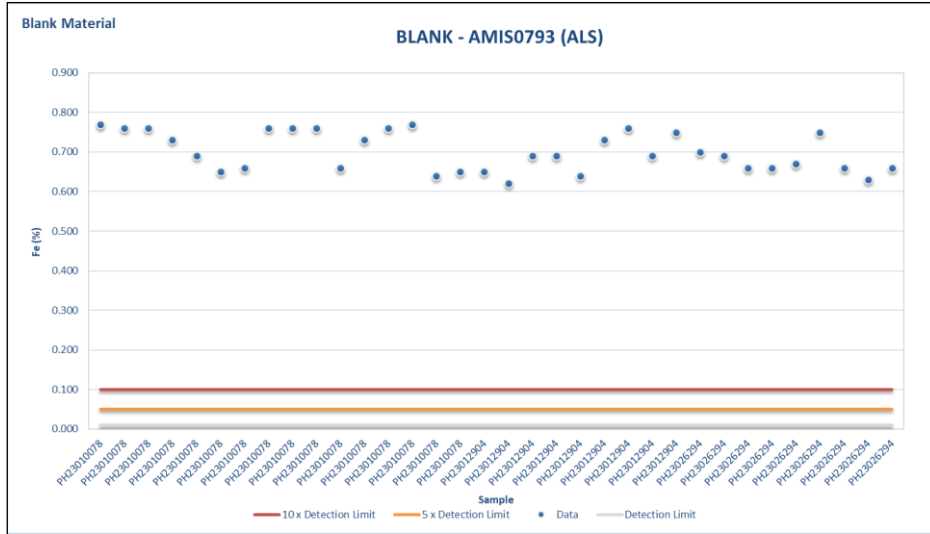


For personal use only

### APPENDIX 3: Blank Material Analysis



For personal use only



For personal use only

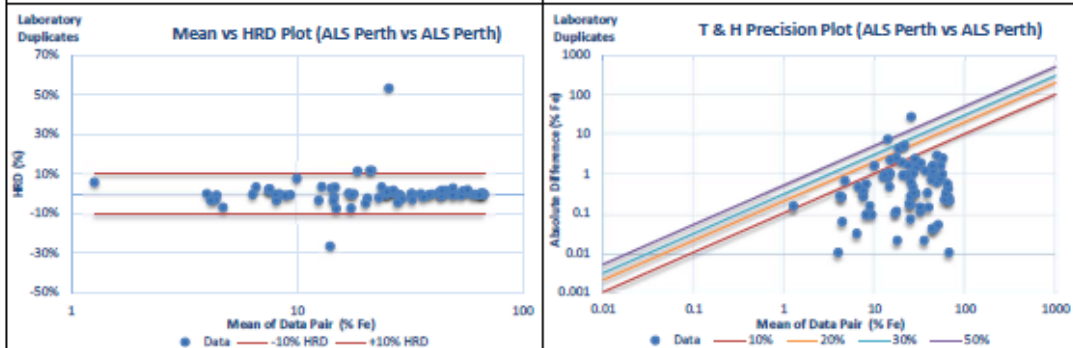
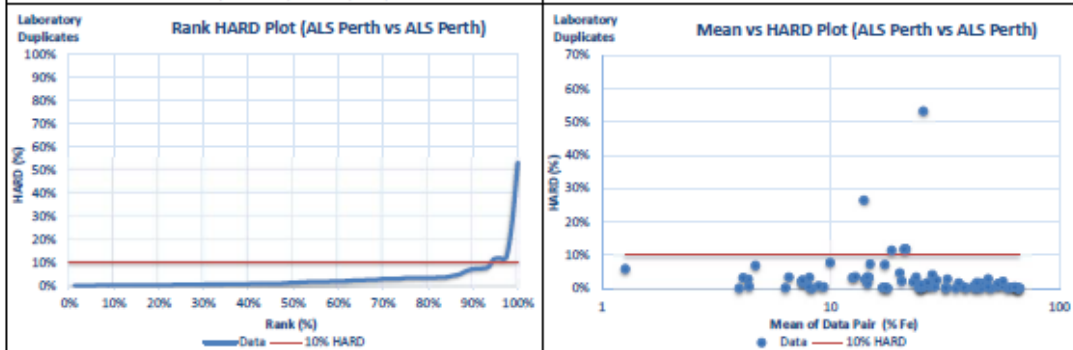
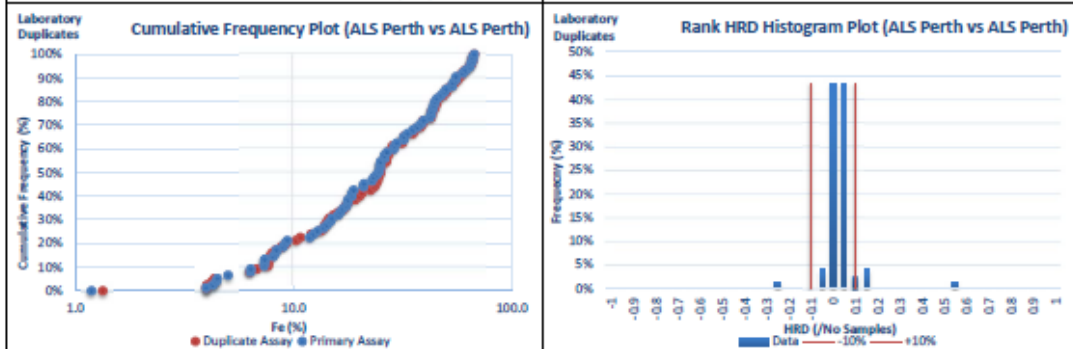
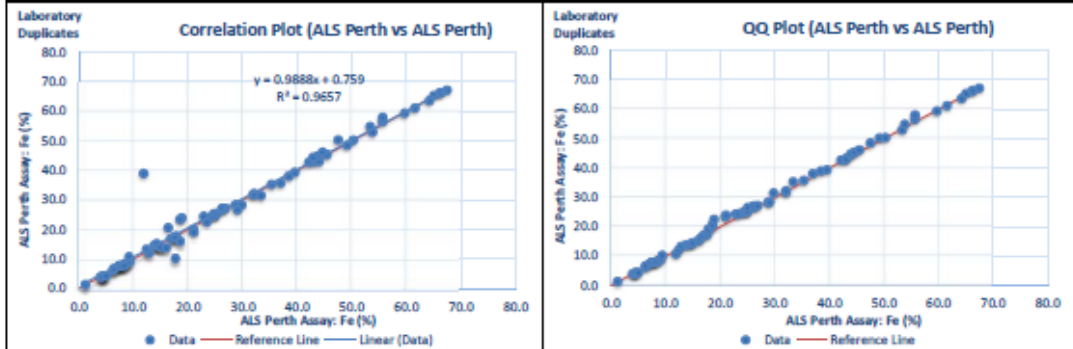
#### APPENDIX 4: Pulp Duplicate Analysis

Summary of Duplicate Assay Results (Bekisopa South)				
Drilling Campaign	Laboratory	Duplicate Type	Number of Duplicate Pairs	% of Duplicate Pairs Meeting HARD Criteria
2020	ALS Perth	PULP	4	100
2021	ALS Perth	PULP	76	94.7
2022	ALS Perth	PULP	28	100
2022 (ALS Internal)	ALS Perth	PULP	101	100

Akora Duplicate Performance 2020 (Bekisopa South)			
Sample No.	Assay Lab	Reported Grade (Fe%)	Duplicate Grade (Fe%)
O7790	ALS (Ireland)	41.53	42.79
O7850	ALS (Ireland)	63.66	63.03
O7890	ALS (Ireland)	55.84	56.86
O7950	ALS (Perth)	65.63	65.17

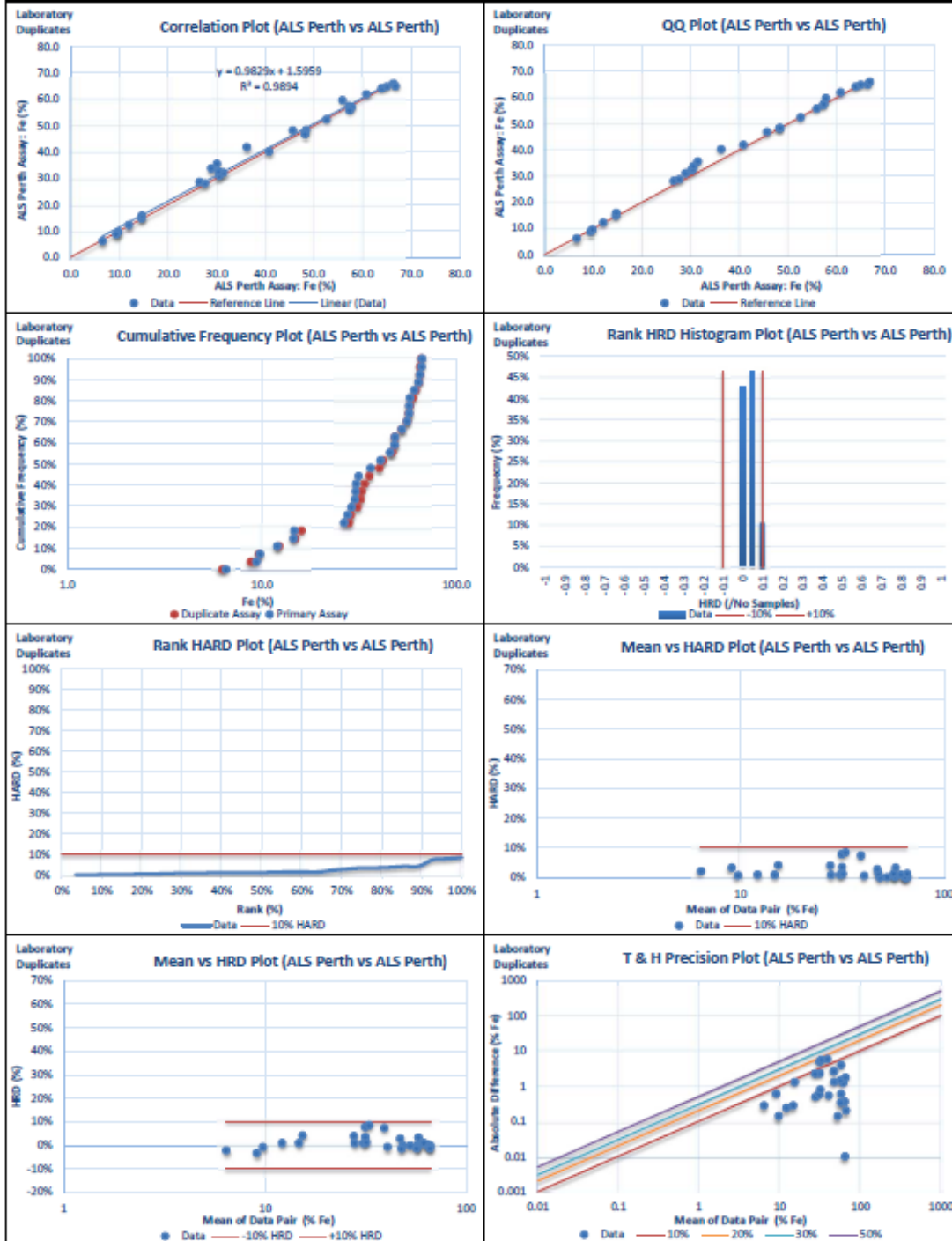
For personal use only

Bekisopa Project   2021 Campaign   ALS Perth vs ALS Perth   Laboratory Duplicates   Fe				
Primary Laboratory: ALS Perth		Primary	Duplicate	Primary vs Duplicate
Assay Method 1: ME-XRF21u + OA-GRA05x	Minimum:	1.19	1.34	Correlation Coefficient: 0.98
Duplicate Laboratory: ALS Perth	Maximum:	67.49	67.29	Mean HARD: 3.15%
Assay Method 2: ME-XRF21u + OA-GRA05x	Mean:	27.80	28.25	Median HARD: 1.27%
Number of Pairs: 76	Median:	24.48	25.02	Mean HRD: 0.68%
Element: Fe	Standard Deviation:	18.71	18.83	Median HRD: 0.02%
Unit: %	Coefficient of Variation:	0.67	0.67	% of Pairs < 10% HARD: 94.7%



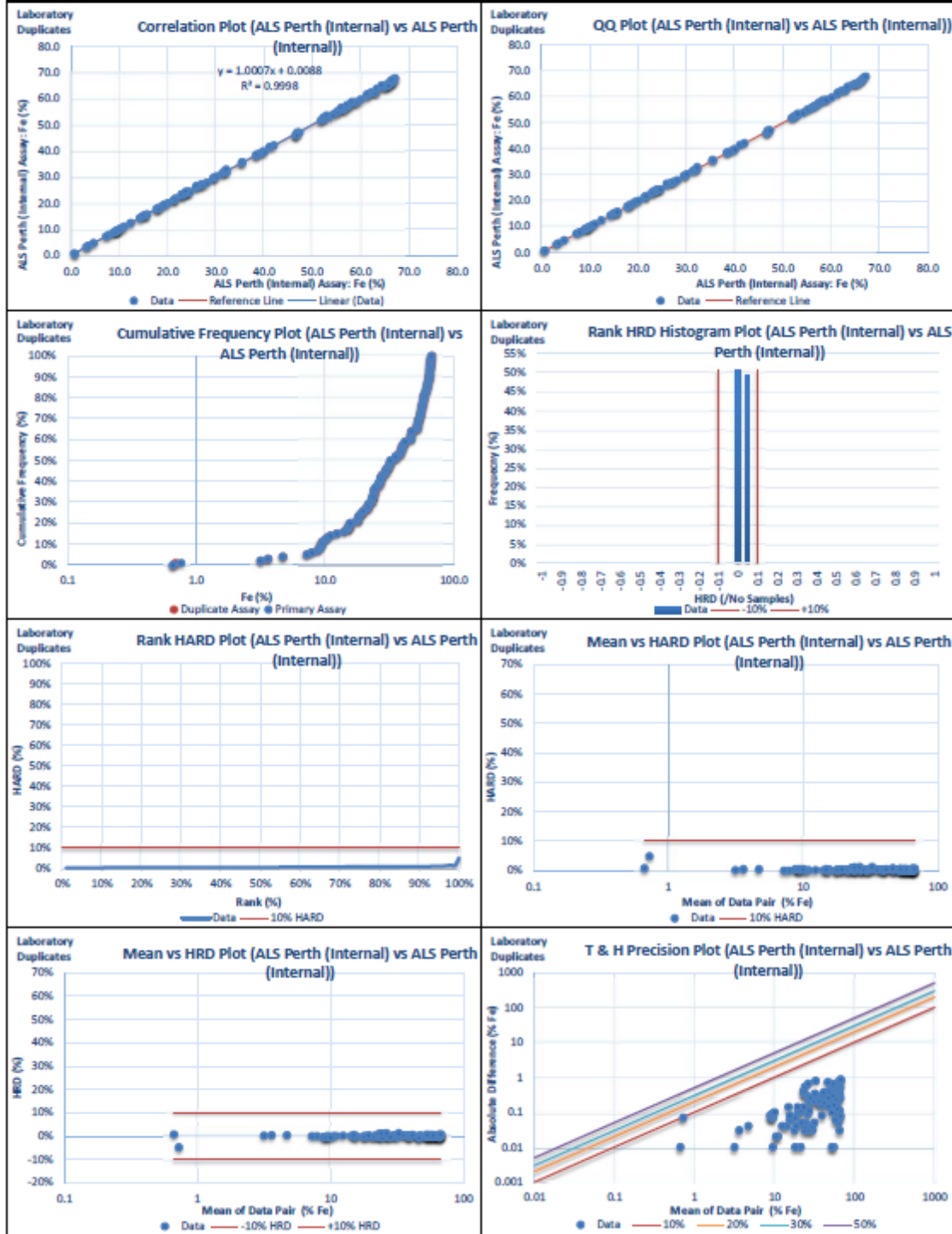
For personal use only

Bekisopa Project   2022 Campaign   ALS Perth vs ALS Perth   Laboratory Duplicates   Fe					
Primary Laboratory: ALS Perth		Primary	Duplicate		Primary vs Duplicate
Assay Method 1: ME-XRF21u + OA-GRA05k	Minimum:	6.55	6.27	Correlation Coefficient:	0.99
Duplicate Laboratory: ALS Perth	Maximum:	66.8	66.17	Mean HARD:	2.14%
Assay Method 2: ME-XRF21u + OA-GRA05k	Mean:	39.13	40.06	Median HARD:	1.12%
Number of Pairs: 28	Median:	38.52	41.15	Mean HRD:	1.31%
Element: Fe	Standard Deviation:	19.61	19.38	Median HRD:	0.99%
Unit: %	Coefficient of Variation:	0.50	0.48	% of Pairs < 10% HARD:	100.0%



For personal use only

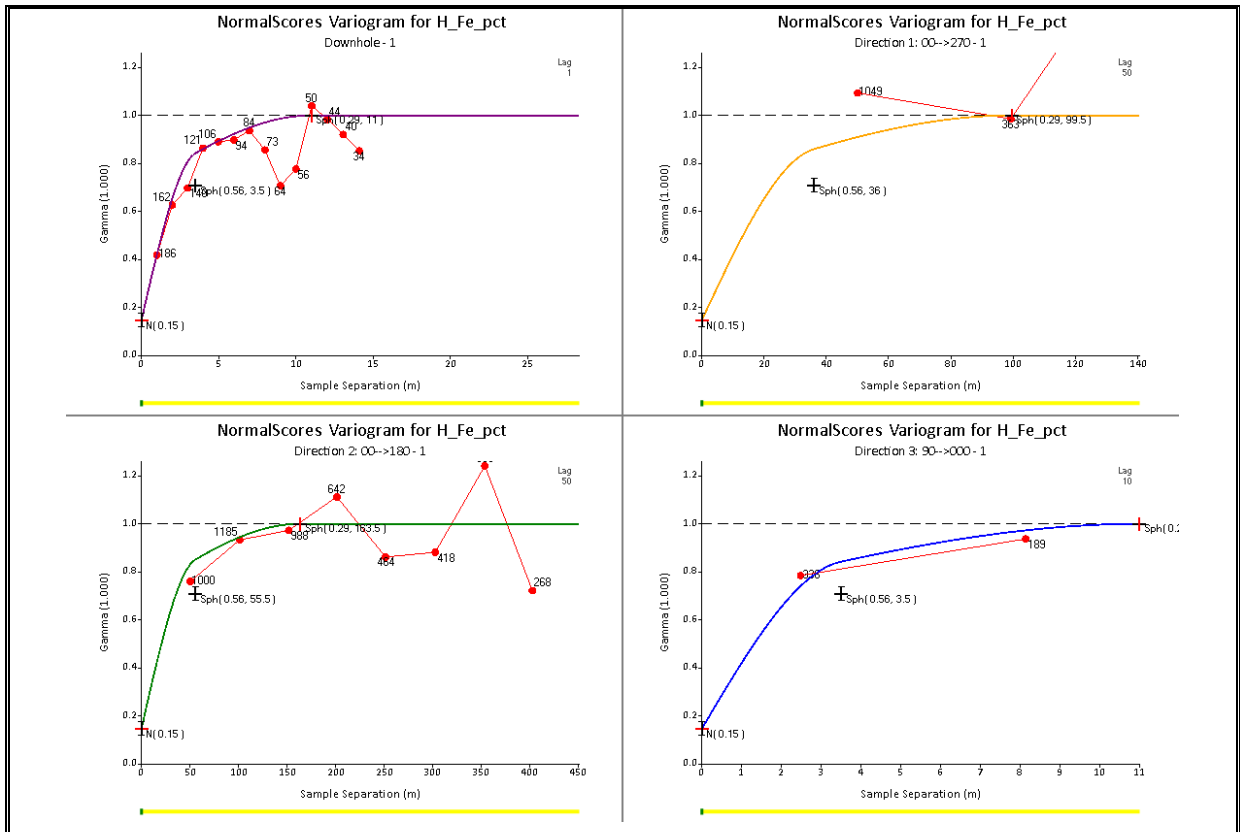
Bekisopa Project   2022 Campaign   ALS Perth (Internal) vs ALS Perth (Internal)   Laboratory Duplicates   Fe					
Primary Laboratory: ALS Perth (Internal)		Primary	Duplicate		Primary vs Duplicate
Assay Method 1: ME-XRF21u + OA-GRA05x	Minimum:	0.66	0.67	Correlation Coefficient:	1.00
Duplicate Laboratory: ALS Perth (Internal)	Maximum:	67.13	67.94	Mean HARD:	0.33%
Assay Method 2: ME-XRF21u + OA-GRA05x	Mean:	36.57	36.60	Median HARD:	0.26%
Number of Pairs: 101	Median:	32.23	32.96	Mean HRD:	0.00%
Element: Fe	Standard Deviation:	20.63	20.63	Median HRD:	0.00%
Unit: %	Coefficient of Variation:	0.56	0.56	% of Pairs < 10% HARD:	100.0%



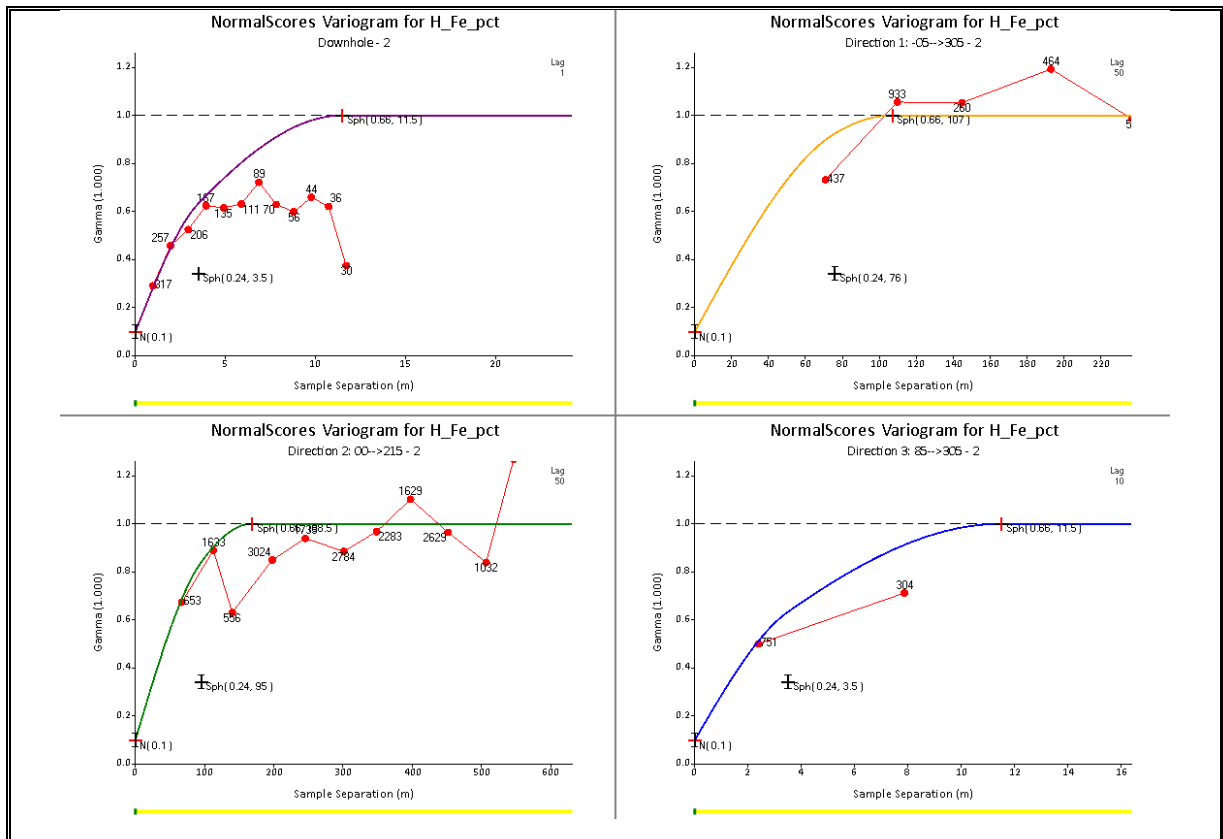
For personal use only

For personal use only

## APPENDIX 5: Variography

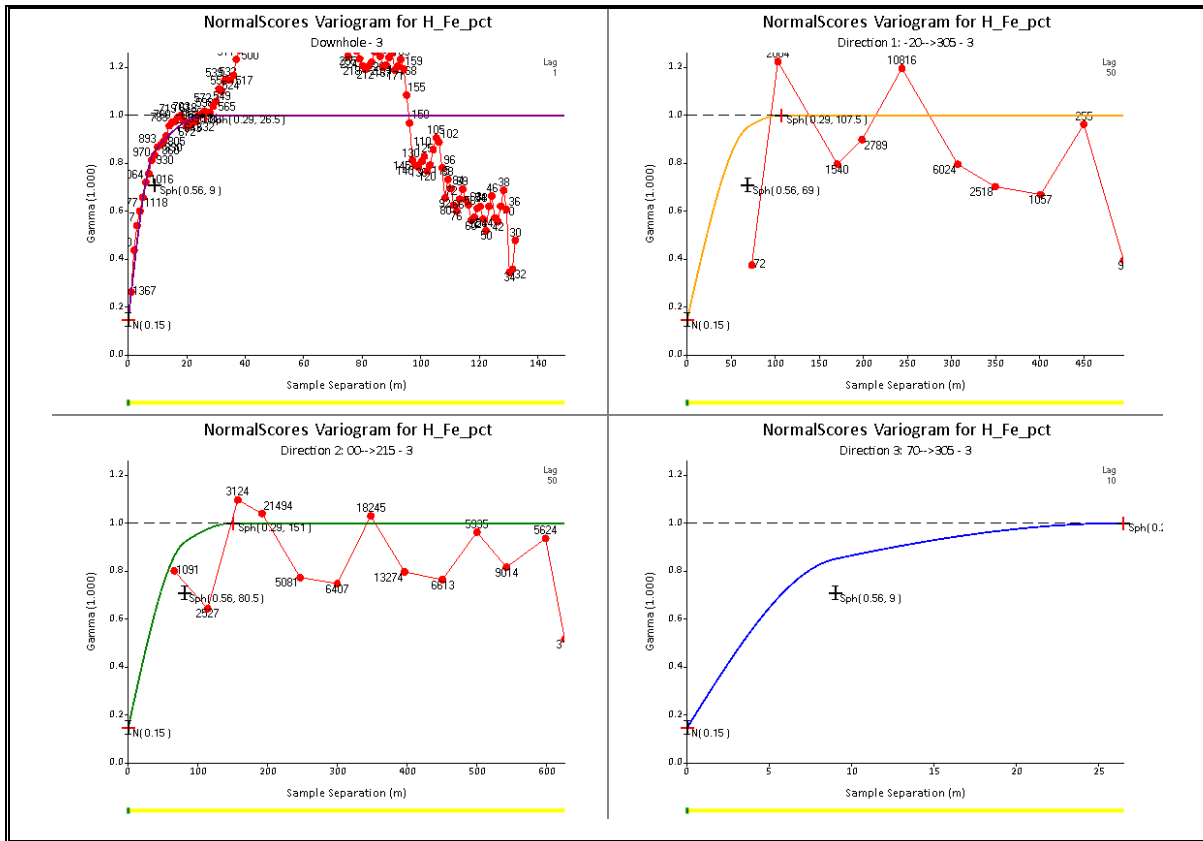


Experimental Variograms Fe (%) for MINDOM 1



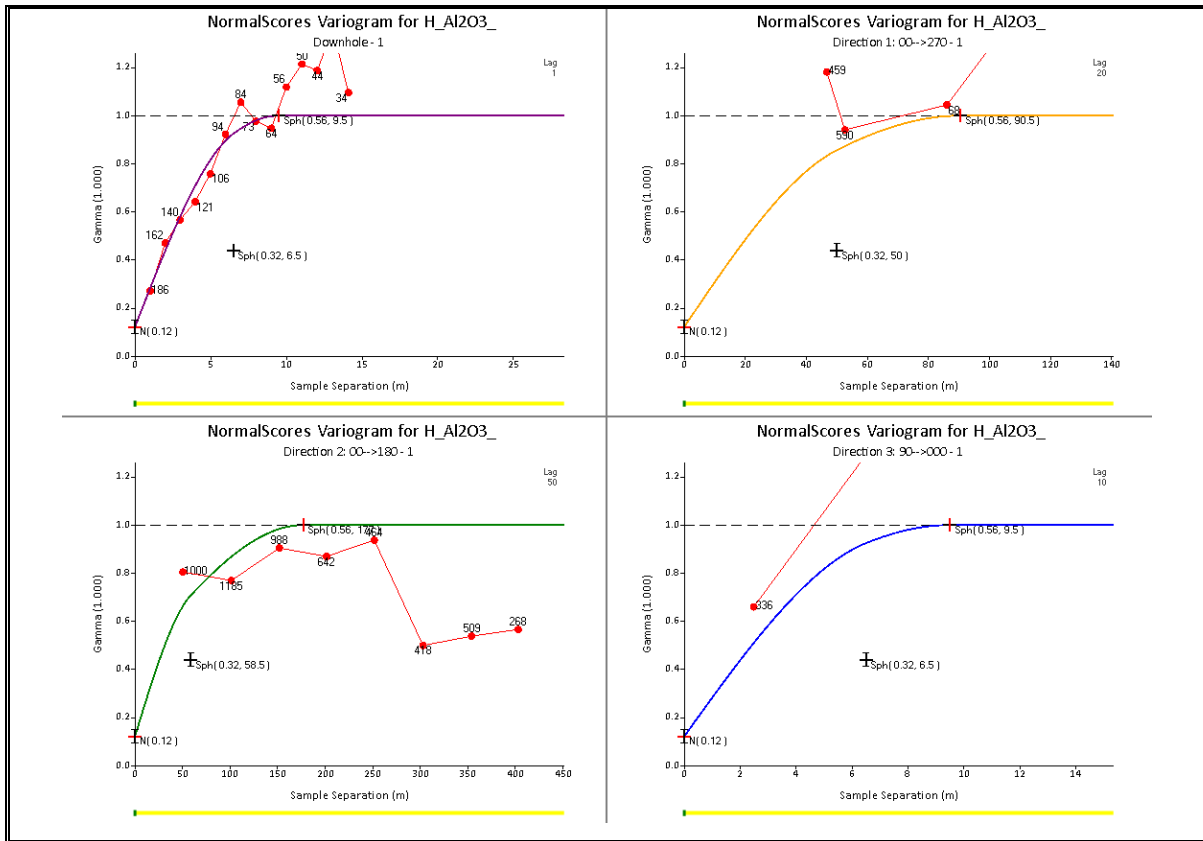
Experimental Variograms Fe (%) for MINDOM 2

For personal use only

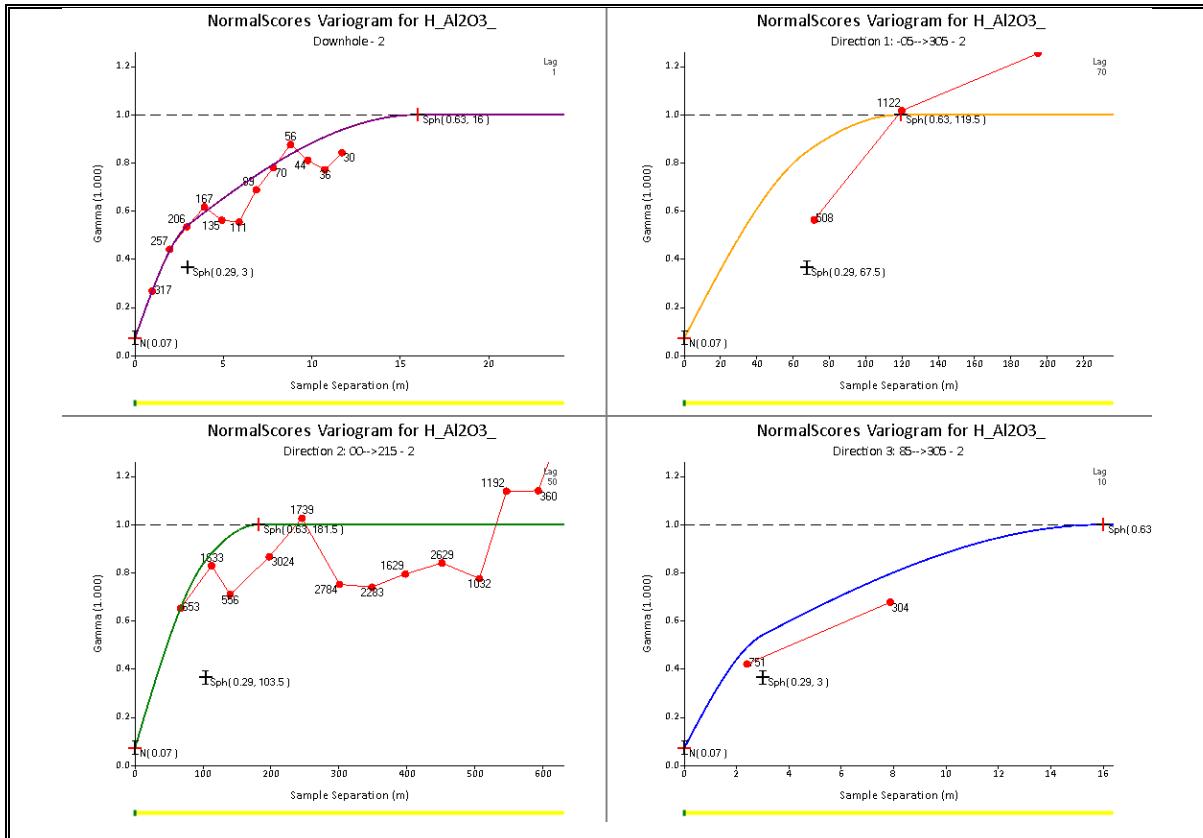


Experimental Variograms Fe (%) for MINDOM 3

For personal use only

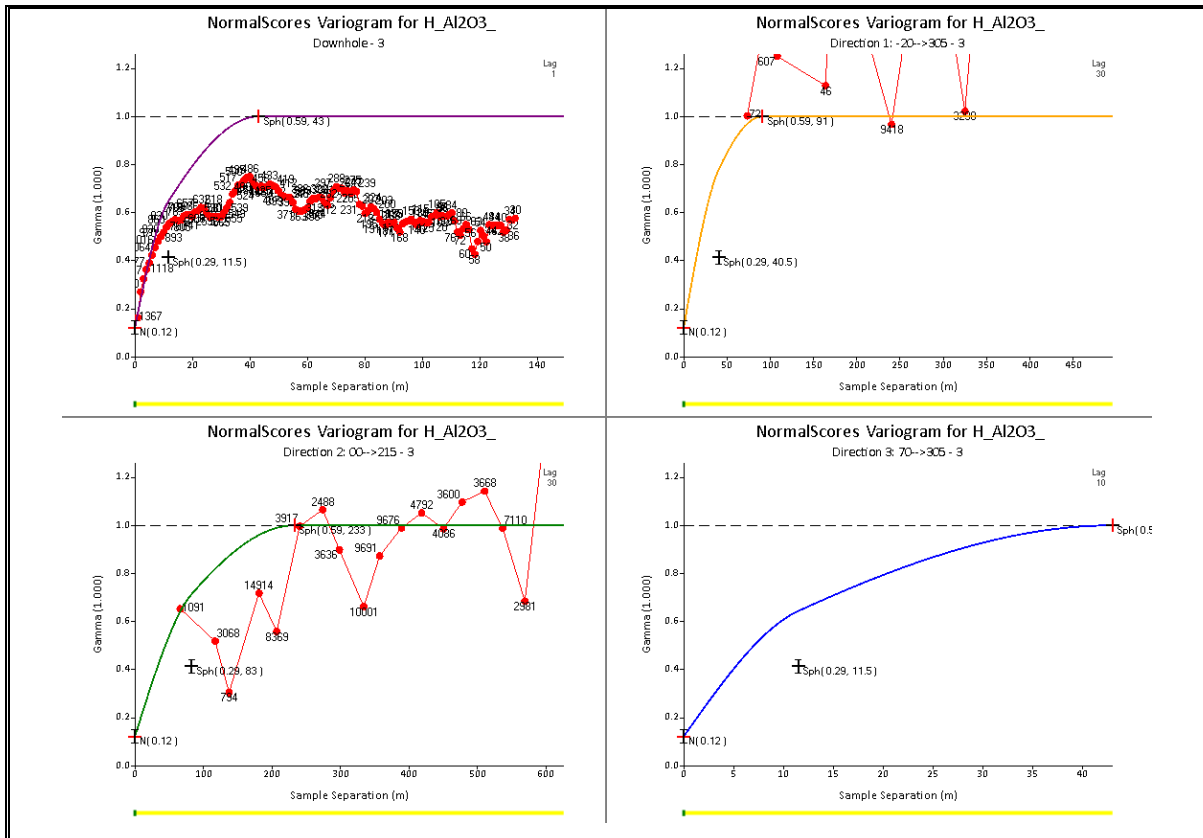


**Experimental Variograms Al2O3 (%) for MINDOM 1**



**Experimental Variograms Al2O3 (%) for MINDOM 2**

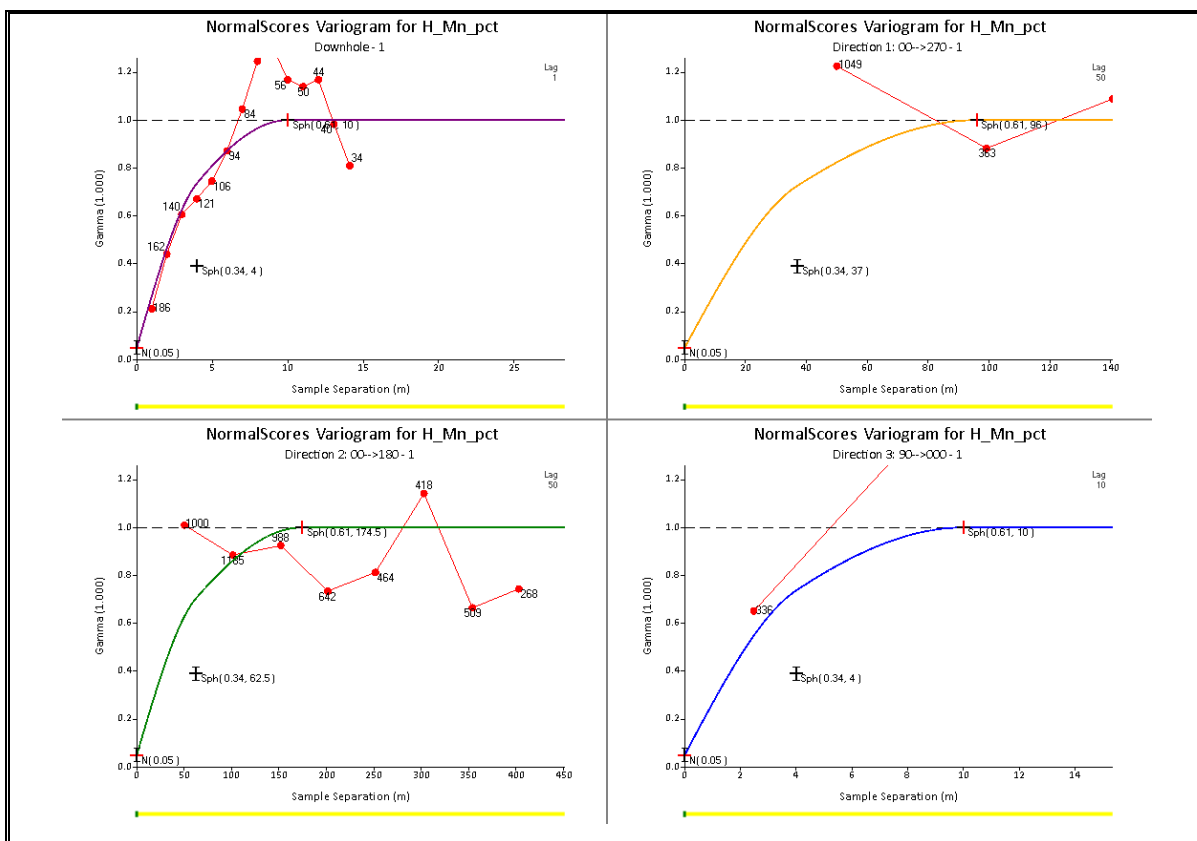
For personal use only



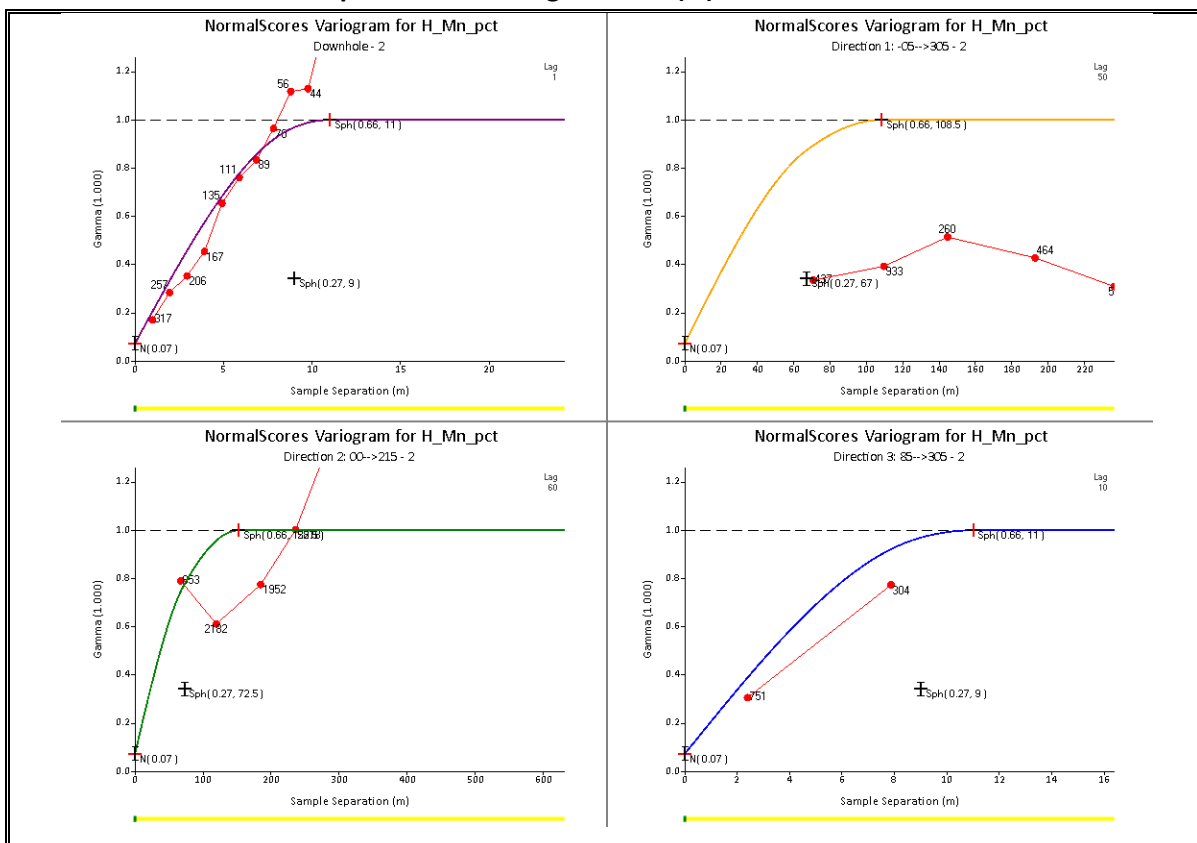
Experimental Variograms Al<sub>2</sub>O<sub>3</sub> (%) for MINDOM 3

For personal use only

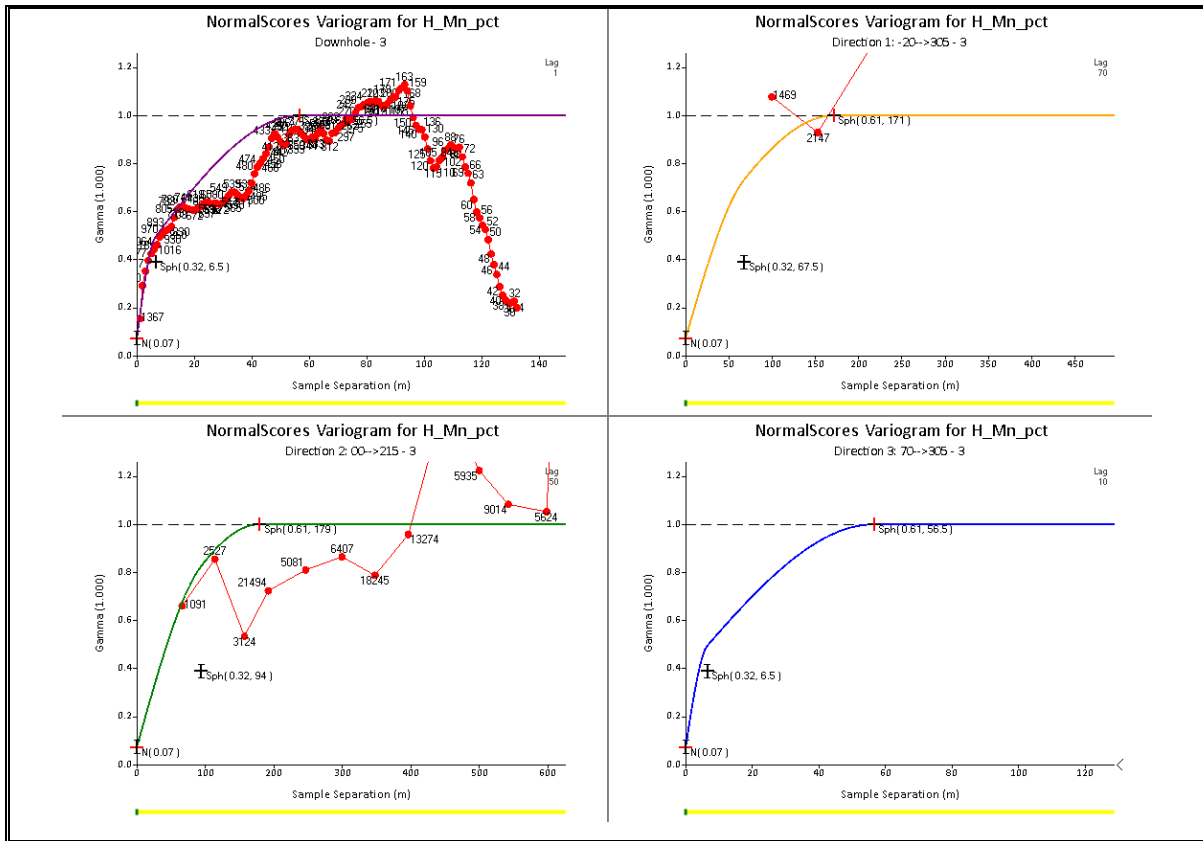
For personal use only



**Experimental Variograms Mn (%) for MINDOM 1**



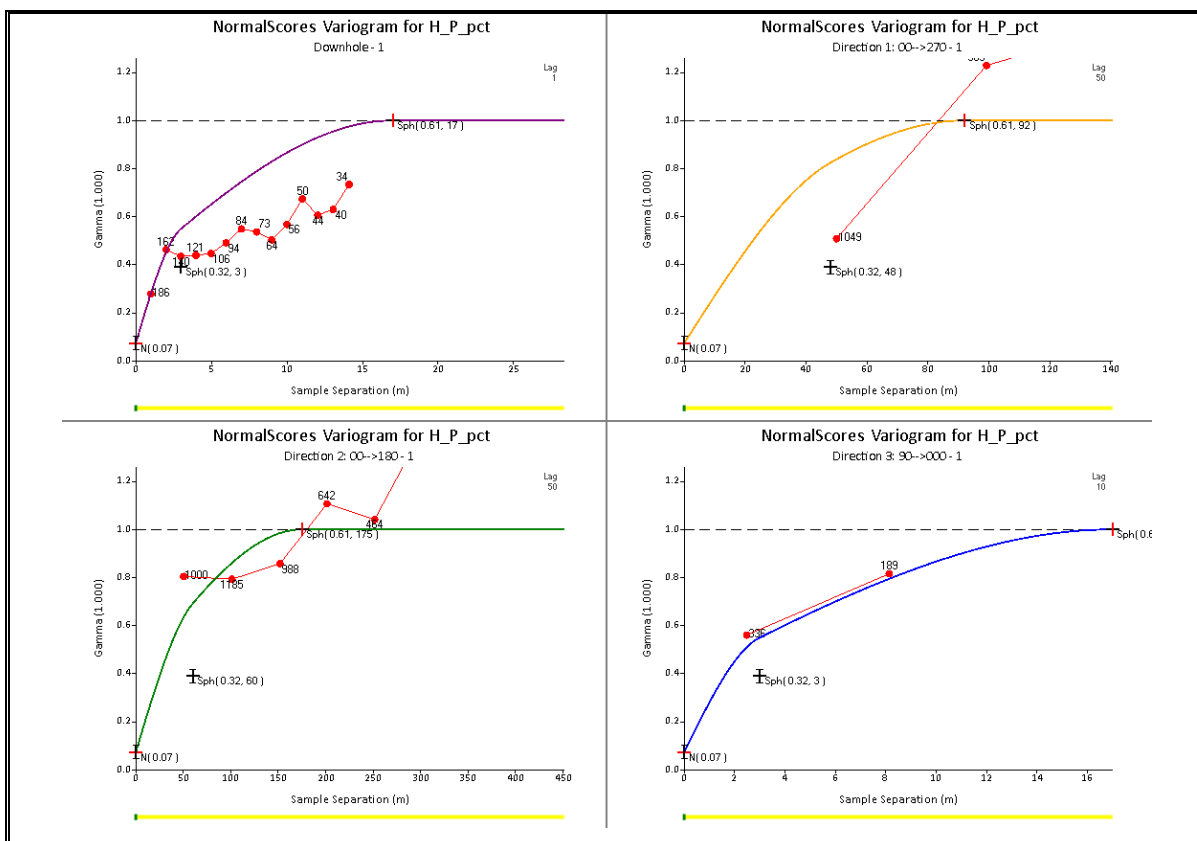
**Experimental Variograms Mn (%) for MINDOM 2**



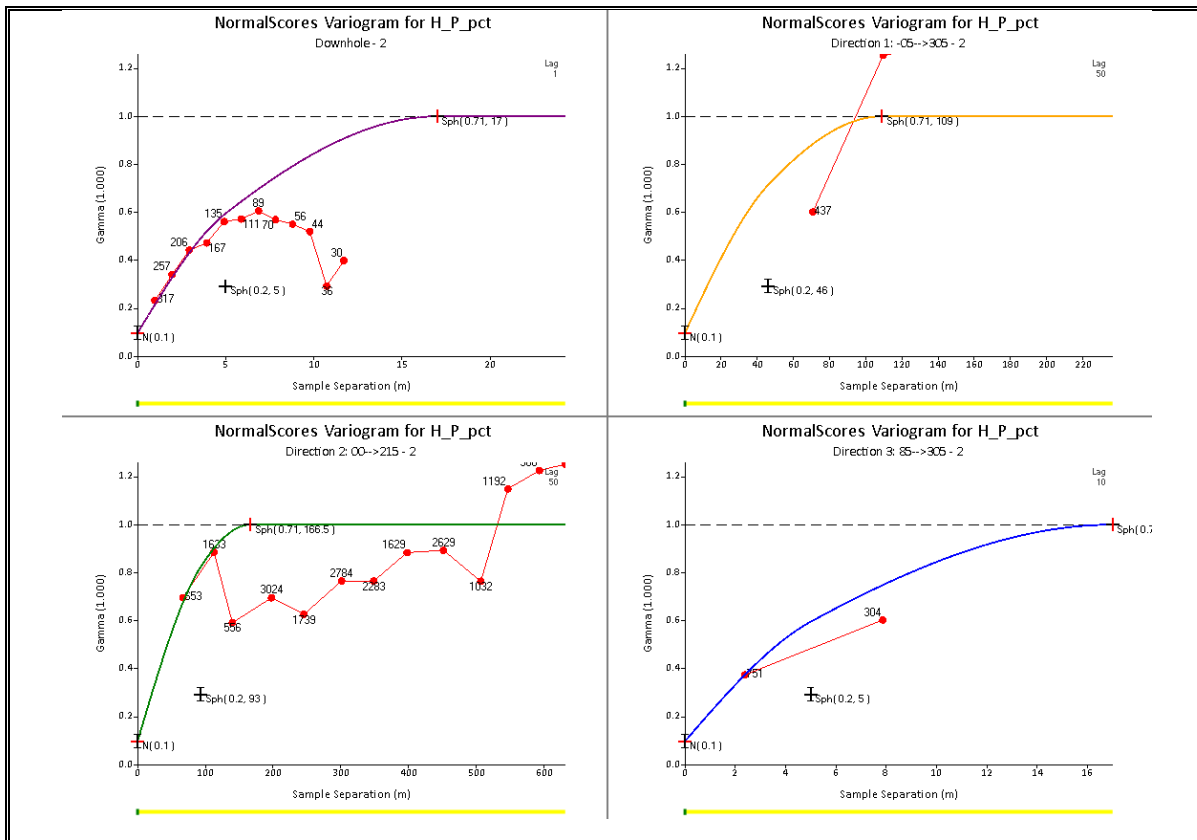
Experimental Variograms Mn (%) for MINDOM 3

For personal use only

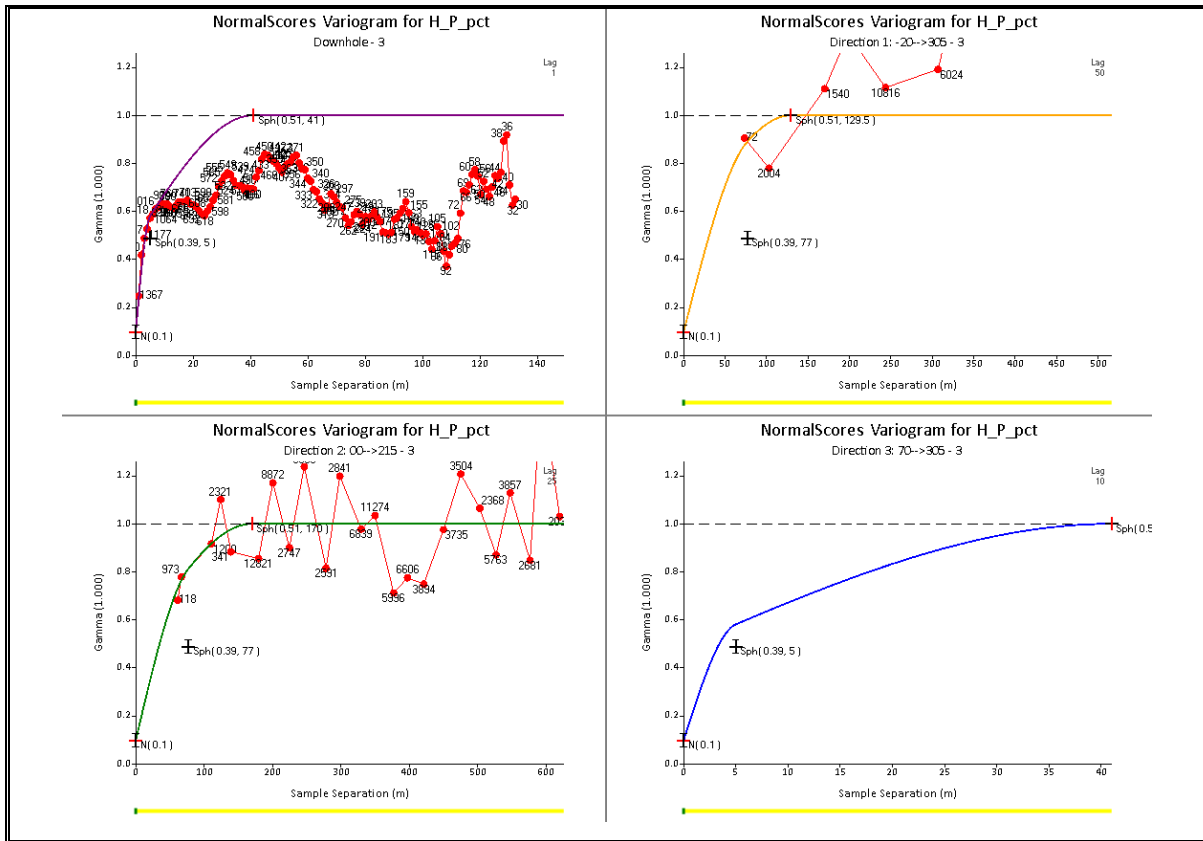
For personal use only



**Experimental Variograms P (%) for MINDOM 1**

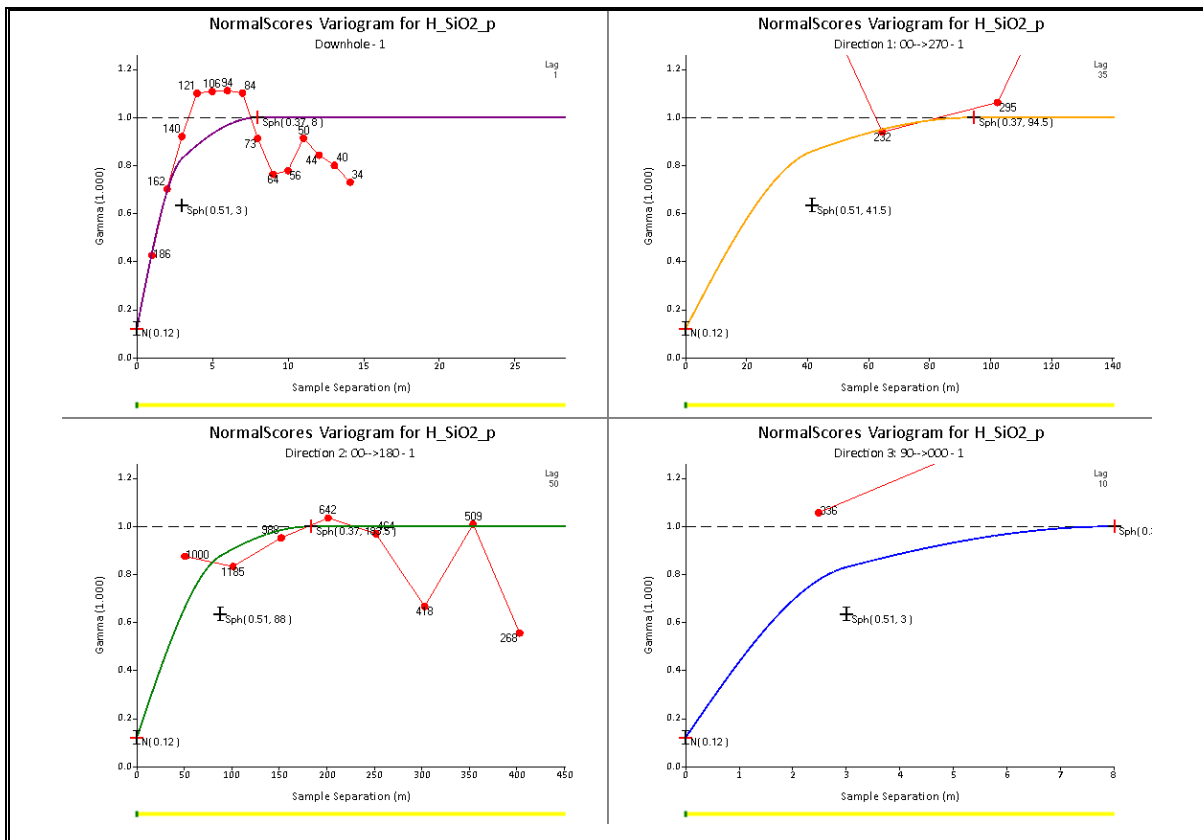


**Experimental Variograms P (%) for MINDOM 2**

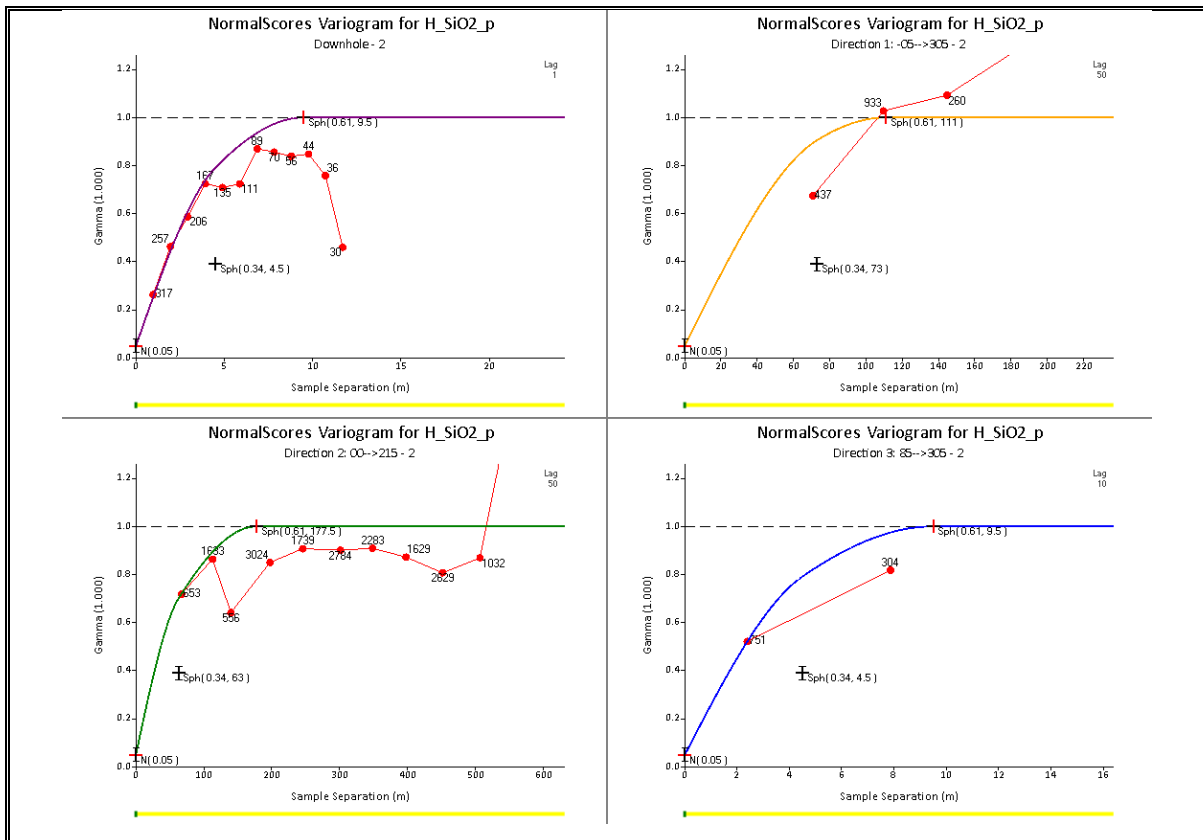


Experimental Variograms P (%) for MINDOM 3

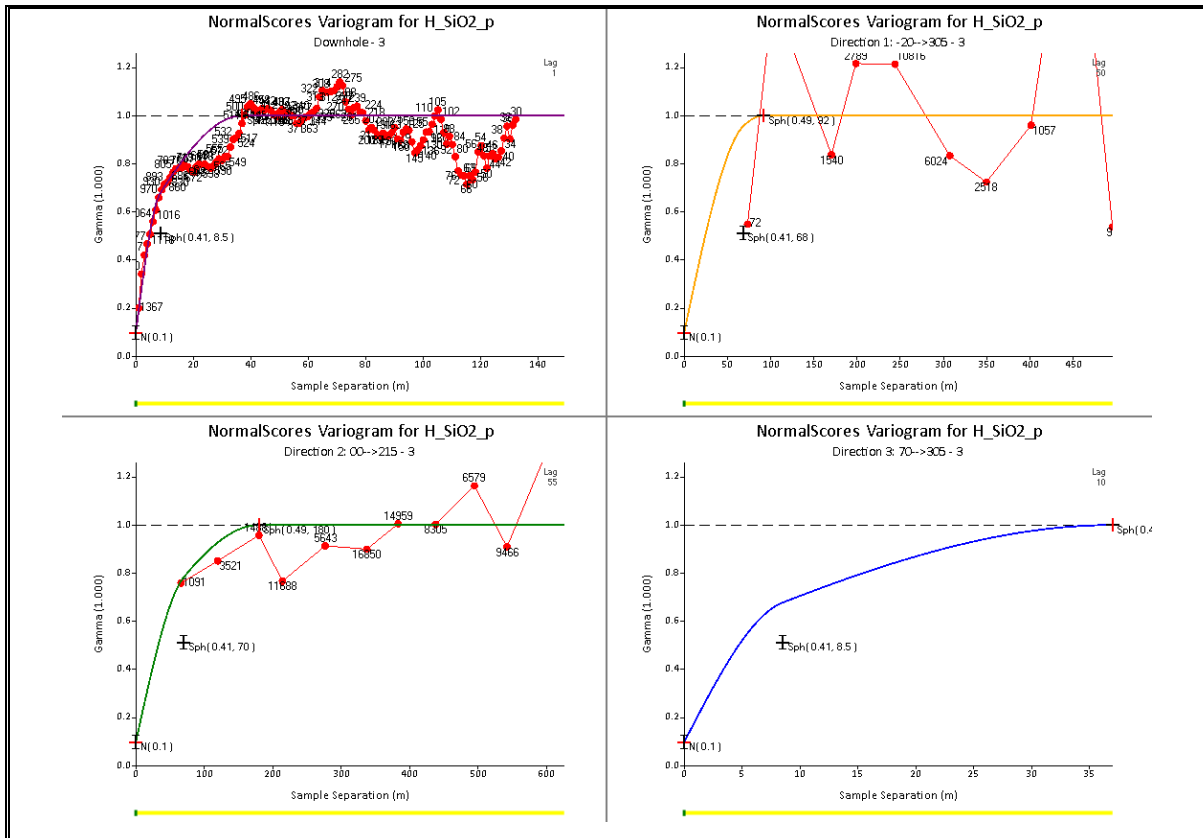
For personal use only



Experimental Variograms SiO2 (%) for MINDOM 1

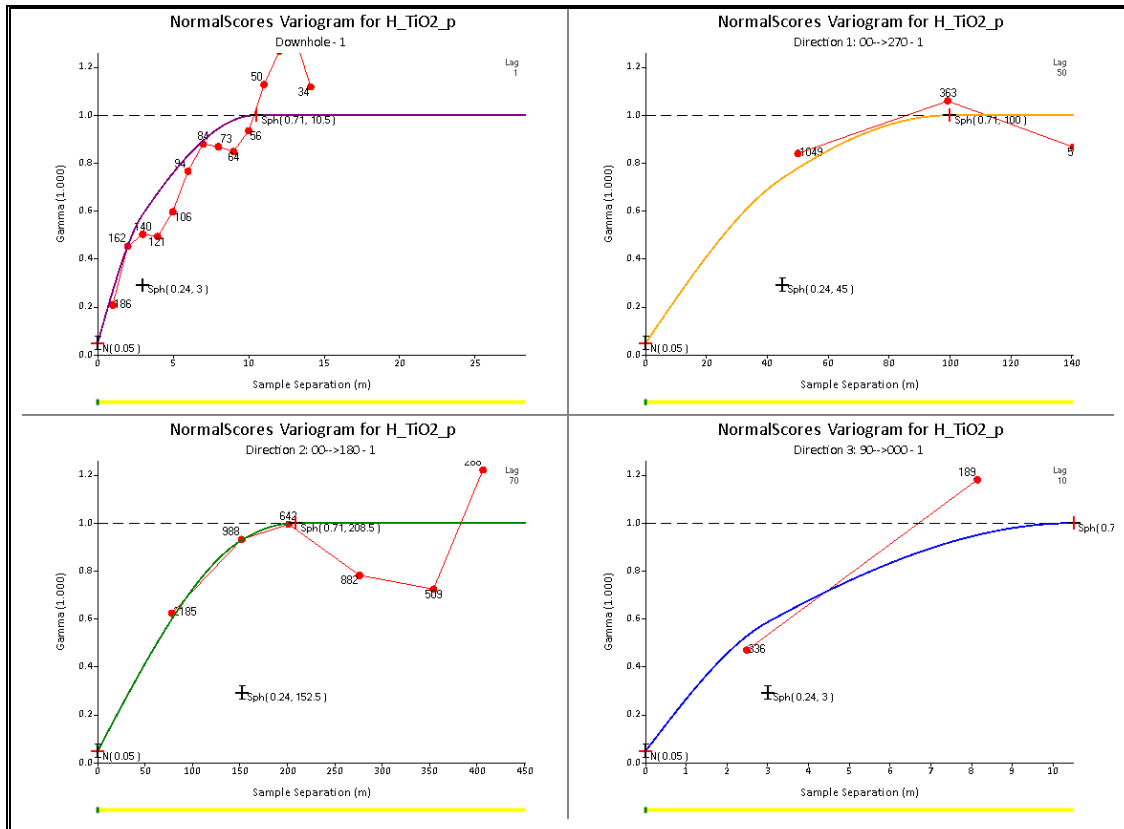


Experimental Variograms SiO2 (%) for MINDOM 2

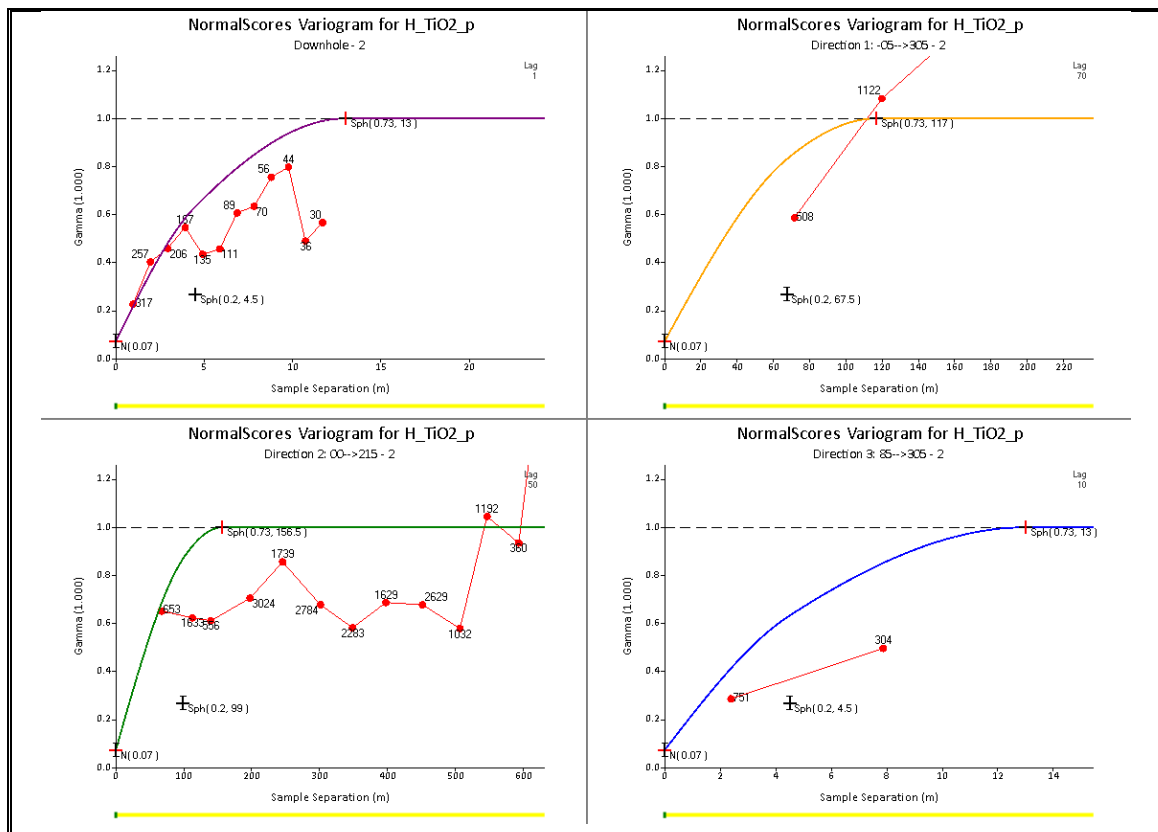


Experimental Variograms SiO2 (%) for MINDOM 3

For personal use only

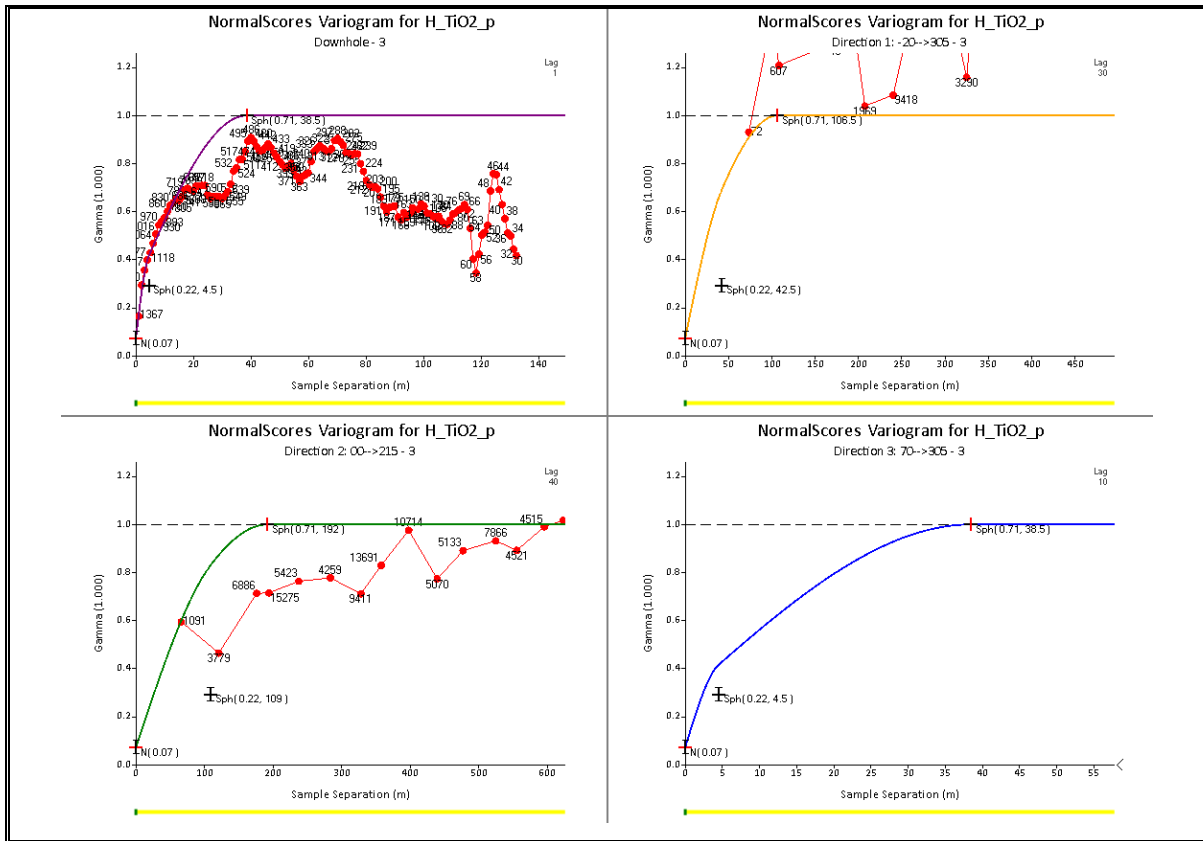


**Experimental Variograms TiO2 (%) for MINDOM 1**



**Experimental Variograms TiO2 (%) for MINDOM 2**

For personal use only



Experimental Variograms TiO<sub>2</sub> (%) for MINDOM 3

For personal use only

**STOKE-ON-TRENT**

Sir Henry Doulton House  
Forge Lane  
Etruria  
Stoke-on-Trent  
ST1 5BD  
Tel: +44 (0)1782 276 700

**BIRMINGHAM**

Two Devon Way  
Longbridge Technology Park  
Longbridge  
Birmingham  
B31 2TS  
Tel: +44 (0)121 580 0909

**BOLTON**

41-50 Futura Park  
Aspinall Way  
Middlebrook  
Bolton  
BL6 6SU  
Tel: +44 (0)1204 227 227

**BRISTOL**

Temple Studios  
Temple Gate  
Redcliffe  
Bristol  
BS1 6QA  
Tel: +44 (0)117 203 4477

**BURY ST EDMUNDS**

Armstrong House  
Lamdin Road  
Bury St Edmunds  
Suffolk  
IP32 6NU  
Tel: +44 (0)1284 765 210

**CARDIFF**

Tudor House  
16 Cathedral Road  
Cardiff  
CF11 9LJ  
Tel: +44 (0)292 072 9191

**CARLISLE**

Marconi Road  
Burgh Road Industrial Estate  
Carlisle  
Cumbria  
CA2 7NA  
Tel: +44 (0)1228 550 575

**EDINBURGH**

Great Michael House  
14 Links Place  
Edinburgh  
EH6 7EZ  
Tel: +44 (0)131 555 3311

**GLASGOW**

24 St Vincent Place  
Glasgow  
G1 2EU  
Tel: +44 (0)141 428 4499

**LEEDS**

36 Park Row  
Leeds  
LS1 5JL  
Tel: +44 (0)113 831 5533

**LONDON**

Third Floor  
46 Chancery Lane  
London  
WC2A 1JE  
Tel: +44 (0)207 242 3243

**NEWCASTLE UPON TYNE**

City Quadrant  
11 Waterloo Square  
Newcastle upon Tyne  
NE1 4DP  
Tel: +44 (0)191 232 0943

**TRURO**

Baldhu House  
Wheal Jane Earth Science Park  
Baldhu  
Truro  
TR3 6EH  
Tel: +44 (0)187 256 0738

**International office:**

**ALMATY**

29/6 Satpaev Avenue  
Hyatt Regency Hotel  
Office Tower  
Almaty  
Kazakhstan  
050040  
Tel: +7(727) 334 1310

For personal use only